

Hustler® Z Diesel Operator's Manual

**SMOOTHTRAK™
STEERING**



HUSTLER®
ENGINEERING PERFORMANCE™

200 South Ridge Road
Hesston, Kansas
67062

WARNING

The engine exhaust from this product contains chemicals known to the state of California to cause cancer, birth defects or other reproductive harm.

NOTICE OF REQUIREMENT OF SPARK ARRESTER MUFFLER

This equipment may create sparks that can start fires around dry vegetation. California Public Resources Code Section 4442.6 provides that it is unlawful to use or operate an internal combustion engine on any forest-covered, brush-covered, or grass-covered land unless the engine is equipped with a spark arrester maintained in effective working order. A spark arrester is a device constructed of nonflammable materials specifically for the purpose of removing and retaining carbon and other flammable particles over 0.0232 of an inch in size from the exhaust flow of an internal combustion engine that uses hydrocarbon fuels or which is qualified and rated by the United States Forest Service. Other states or federal areas may have similar laws. The Operator Should Contact Local Fire Agencies For Laws or Regulations Relating to Fire Prevention Requirements. THIS EQUIPMENT DOES NOT HAVE A SPARK ARRESTER AND YOU SHOULD CONTACT YOUR AUTHORIZED DEALER FOR THE PURCHASE OF A SPARK ARRESTER.

Inspect spark arrester daily; replace every 500 hours or as needed.

The Engine Owner's Manual provides information regarding the U.S. Environmental Protection Agency (EPA) and the California Emission Control Regulation of emission systems, maintenance and warranty.

Keep Engine Owner's Manual with your unit. Should the Engine Owner's Manual become damaged or illegible, replace immediately. Replacements may be ordered per the information found in the Product Information section of the owner's manual.

Federal law and California State law prohibit the following acts or the causing thereof:

- 1. The removal or rendering inoperative by any person other than for purposes of maintenance, repair, replacement, of any device or element of design incorporated into any equipment for the purposes of emissions control prior to or after its sales or delivery to the ultimate purchaser or while it is in use, or**
- 2. The use of the equipment after such device or element of design has been removed or rendered inoperative by any person.**

Table of Contents

General Information	1-1
To the New Owner	1-1
Using this Manual	1-1
Warranty Registration	1-1
Model and Serial Number	1-1
Parts and Service	1-1
Product Literature	1-2
Safety Precautions	2-1
Safe Operating Practices	2-1
Service Precautions	2-4
Safety and Instructions Decals	2-6
Operation	3-1
Safe Operating Practices	3-1
Control Panel	3-1
Controls	3-3
Safety Start Interlock System	3-4
Engine Starting	3-4
Stopping the Engine	3-5
Moving the Mower with Stalled Engine	3-5
ROPS (Roll Over Protective Structure)	3-5
Mower Operation	3-7
Deck Cutting Height Adjustment	3-11
Air Flow Baffles	3-11
Anti-scalp Wheels	3-12
Maintenance & Adjustments	4-1
Safe Servicing Practices	4-1
Service Introduction	4-1
Torque Values	4-1
Tires	4-1
Flex Forks [®] Break-In	4-1
Lubrication	4-1
Electrical System	4-2
Hydraulic System	4-2
Fuel System	4-3
Engine Air Filter	4-5
General Engine Maintenance	4-6
Belts	4-6
Mower Blade	4-7

Seat Adjustment 4-8
Steering Control Lever Adjustment 4-10
Maintenance Record 4-15

Troubleshooting 5-1

Storage 6-1

GENERAL INFORMATION

This manual applies to the following Hustler® Turf Equipment product lines:

Hustler® Z Diesel

To the New Owner

Hustler® mower owners and operators **must read** this manual carefully. It contains operation and maintenance information that will help you achieve years of dependable service.

The Engine Owner's Manual, included in the owner's packet, contains engine information that will not be repeated in this manual.

The **owner's responsibilities** include, but are not limited to, making certain that the operators and mechanics:

- read and understand the engine owner's manual before attempting to operate or repair the engine.
- read and understand the mower's operator manual and all decals before operating this machine.
- are qualified and physically able individuals, properly trained in the operation and maintenance of this equipment. Before they are allowed to operate or maintain this machine, they **must** be familiar with its safe operation, operator controls, and decals.
- know they are responsible for their own safety as well as the safety of other persons within the vicinity. **Remember**, the operator is responsible for accidents or hazards occurring to other people or their property.
- who cannot read and understand English have this material explained to them.

IMPORTANT: As the owner/operator you can prevent accidents. You are responsible for accidents or injuries occurring to yourself, other people or property.

Never let children or untrained people operate or service the equipment. Local regulations may restrict the age of the operator.

For more detailed maintenance and adjustment information refer to the proper *General Service Manual* for your machine. Refer to the *Product Literature* section of this manual for information on how to obtain this manual.

Using this Manual

This manual contains general operation information as well as basic adjustment and maintenance information. Since operating conditions vary considerably, all conditions cannot be addressed individually. Through training and experience, operators should develop safe operating practices suitable to most conditions.

Directions used in this manual, for example RIGHT or LEFT, refer to directions when in the operator position and facing forward, unless otherwise stated.

Though current at the time of printing, photographs and illustrations shown may vary slightly from your mower due to subsequent production changes. Hustler® Turf Equipment, Inc. reserves the right to redesign and change the machine as deemed necessary, without notification. If a change has been made to your machine which is not reflected in this manual, contact your Hustler® Dealer for current information.

Warranty Registration

To activate your warranty policy the mower **must** be registered, by your Dealer, with the Manufacturer of Hustler® Turf Equipment within **ten (10) days** following the date of purchase. It is recommended that you contact your Dealer to make sure the mower is registered.

IMPORTANT: The mower and any attachment that displays a model and serial identification number plate **must** be registered with Excel Industries, Inc., manufacturer of Hustler® Turf Equipment, Inc ("Manufacturer").

IMPORTANT: Any unauthorized modification, alteration, or use of non-approved attachments voids the warranty and releases Manufacturer from any liability arising from subsequent use of this equipment. **Do not** use or operate any attachment not approved by Hustler® Turf Equipment, Inc.

IMPORTANT: Damage caused by unauthorized replacement parts is not covered by this warranty. Manufacturer expressly excludes liability for defects or damage caused by such 'unauthorized' articles or service.

Model and Serial Number

The serial identification plate, located directly below and to the left of the operator's platform, contains the mower's model and serial numbers.

These numbers are required when the unit is registered with Hustler® Turf Equipment. They will also assure you of the correct service parts when replacement becomes necessary.

Parts and Service

Use original Hustler® replacement parts, or parts that are equivalent in overall performance, that are available from your local Hustler® Dealer. For prompt, efficient service, always provide the following information when ordering parts:

1. Correct part description.
2. Correct part number.
3. Correct model number.
4. Correct serial number.

All arrangements for warranty repair and service must be handled through an authorized Hustler® Dealer.

Product Literature

If you would like to view or print a copy of the product manuals (Operator's Manual, Parts Manual, or General Service Manual) for these mowers go online to www.hustlerturf.com.

Contact your local Hustler® dealer if you require another engine manual.

SAFETY PRECAUTIONS



This safety alert symbol is used to call attention to a message intended to provide a reasonable degree of **PERSONAL SAFETY** for operators and other persons during the normal operation and servicing of this equipment.

⚠ DANGER ⚠	<p>– denotes immediate hazards which WILL result in severe personal injury or death.</p>
---------------------------------------	---

⚠ WARNING ⚠	<p>– denotes a hazard or unsafe practice which COULD result in severe personal injury or death.</p>
--	--

This manual uses two other words to highlight information:

- A. **IMPORTANT** – calls attention to special mechanical information.
- B. **NOTE** – emphasizes general information worthy of special attention.

The **owner's responsibilities** include, but are not limited to,

- making certain that the operators and mechanics read and understand this manual and all decals before operating this machine.
- making certain that before the operators and mechanics are allowed to operate or maintain this machine, they **must** be familiar with its safe operation, operator controls, and decals.
- ensuring that the operators and mechanics know they are responsible for their own safety as well as the safety of other persons within the vicinity. **Remember**, the operator is responsible for accidents or hazards occurring to other people or their property.

Improper use, adjustment, or maintenance by the operator, mechanic or owner can result in injury or death. Reduce the potential for injuries by following these safety instructions. Pay close attention to the safety alert symbol “▲” and the instructions that follow it. **Failure to comply with these instructions may result in personal injury or death.**

Incorrect usage of this equipment may result in severe injury or death. Personnel operating and maintaining it should be trained in its proper use. They should read this manual completely and thoroughly before attempting to set-up, operate, adjust, or service this equipment.

Safe Operating Practices

This product is capable of amputating hands and feet and throwing objects. Always follow all safety instructions to avoid serious injury or death.

- ▲ Never allow persons to operate this mower without proper instruction or allow children to operate the mower. Allow only responsible adults who are familiar with these instructions to operate this mower.

Safe Operation

- ▲ Evaluate the terrain to determine what accessories and attachments are needed to properly and safely perform the job. Only use accessories and attachments approved by the manufacturer.
 - Do not use any unauthorized attachment or modify the mower.
 - Follow the manufacturer's recommendation for wheel weights or counterweights.
 - If any attachment or additional weight is mounted on the rear of the unit, any rapid movement of the control levers in either direction could result in a reaction of the mower that can cause serious injury.
- ▲ **Do not** use a catcher on any mower equipped with Flex Forks®.
- ▲ Always be alert and inspect area to be mowed for hazards such as rocks, metal objects and other debris which may be thrown or entangled by mower blades. Remove these objects before mowing. Watch out for holes or deep depressions.
- ▲ Always operate mower in daylight or with adequate working lights.
- ▲ Never operate the mower when there is a risk for lightning.

Personal Safety

- ▲ **Always** wear long pants and safety shoes with slip-resistant soles when operating this mower.
 - Do not wear sandals, tennis shoes, sneakers, shorts or any type of loose fitting clothing as they may get tangled in moving parts.
 - Do not wear a towel from the waist, or use a towel as a headband or neck wrap.
 - Long hair or jewelry may get tangled in moving parts.

- ▲ Always wear adequate ear protection, such as earplugs. Prolonged exposure to loud noise can cause impairment or loss of hearing.
 - Do not wear radios or music headphones while operating this mower. Safe operation requires your full attention.
- ▲ **Always** wear safety goggles or safety glasses with side shields when operating this mower.
- ▲ Do not operate the mower if you are fatigued, sick or while under the influence of alcohol or drugs, if you are pregnant or under 18 years old.
- ▲ Poor posture or operating the mower for extended periods of time may lead to fatigue or injury, resulting in loss of mower control. Occasionally, stop the mower and get off the seat to stretch and relax.
- ▲ Data indicates that operators aged 60 years and above are involved in a large percentage of riding mower-related injuries. These operators should evaluate their ability to operate the mower safely enough to protect themselves and others from serious injury.

Operation

- ▲ Always secure the ROPS in the raised position and buckle the seat belt before starting mower.
- ▲ Never leave a running mower unattended. Before leaving the operator's seat for any reason, including emptying the catcher or unclogging the chute:
 - Always stop on level ground.
 - Disengage the deck clutch.
 - Place the steering control levers in the park brake position.
 - Stop the engine.
 - Remove the ignition key.
 - Wait for the engine and all moving parts to come to a complete stop.
- ▲ Always inspect mower for damage after striking a foreign object. If damage is found, repair mower immediately.
- ▲ Always remain seated while operating the mower. Only start the engine from the operator's position.
- ▲ Turn off the mower blades when not mowing.
- ▲ Always keep safety shields and covers in place, except for servicing.
 - Never operate the machine with the floor plate pulley cover removed.
- ▲ Never operate the mower deck with the discharge chute damaged, altered, removed, or in the raised position, except when the entire grass catcher attachment or mulching system is being used.
- ▲ Always keep clear of the mower blades and attachments during their operation.
 - Never put hands or feet under any part of the mower while it is running.

- ▲ Stop the engine before removing the grass catcher or unclogging the discharge chute. Never clear the discharge chute with the engine running. Turn off the engine and be sure the blades have stopped before cleaning. Use a stick to clear a plugged discharge area. **Never use your hand!**
- ▲ Follow daily and weekly checklists, making sure hoses are tightly secured and bolts are tightened.
 - Never operate a poorly maintained mower.
- ▲ **Clean flammable material from mower. Prevent fires by keeping the engine compartment, top of the deck, exhaust area, battery, fuel line, fuel tank and operator's station clean of accumulated trash, grass clippings, and other debris. Always clean up spilled fuel and oil.**
- ▲ **Prevent fires by keeping the engine and exhaust areas clear of grass clippings and other debris. Do not back mower into flammable materials.**
 - Allow the mower, especially the engine, to cool in a well ventilated area before storing inside a building or other enclosure.
- ▲ Do not change the engine governor setting or over speed the engine. Operating the engine at excessive speed may increase the hazard of personal injury.
- ▲ Rapid movement of the steering control levers in either direction could result in a reaction of the mower that can cause serious injury.
 - Never push forward suddenly on your steering control levers while the mower is in rearward motion because mower may tip backwards.
 - Never pull back suddenly on your steering control levers while the mower is in forward motion.
- ▲ Always be aware of what is behind the mower before backing up. Never mow in reverse. Always look down and behind before and while backing up.
 - If mowing in reverse is unavoidable, push forward slowly on the steering control levers and avoid sudden movement.
- ▲ Slow down before turning.
- ▲ Never attempt high speed maneuvering, especially in crowded or congested areas.
- ▲ Always maintain a safe distance from people and pets when mowing. Always stop mower if someone enters the area.
- ▲ Never carry passengers.
- ▲ Never direct discharged material toward anyone. Avoid discharging material against a wall or obstruction. Material may ricochet back toward the operator. Always disengage the mower blades and wait for them to stop before crossing gravel drives, walks or roads.
- ▲ Always observe traffic laws while driving mower from one location to another. Watch for traffic when operating near or crossing roadways.

- Use care when approaching blind corners, shrubs, trees, or other objects that may obscure your vision.

Using a Ramp

- ▲ Exercise extreme caution when loading and unloading a mower onto a truck or trailer with a ramp.
- ▲ Use only a single, full width ramp; do not use individual ramps for each side of the unit. Having a full width ramp provides a surface for the mower frame to contact if the unit starts to tip backwards. It also reduces the risk of a wheel going off and the mower tipping over.
- ▲ Do not exceed a 15 degree angle between the ramp and the ground or between the ramp and the trailer or truck.
- ▲ Avoid sudden acceleration when on a ramp.

Slope Operation

Slopes are a major factor in loss-of-control and tip-over accidents, which can result in severe injury or death. All slopes require extra caution. If you cannot back the mower up the slope or if you feel uneasy on the slope; do not mow it. REMINDER: Only operate on slopes of 15 degrees or less.

- ▲ Use extreme caution when operating on slopes.
 - Be extremely careful changing directions on a slope. Slow down.
 - Do not operate where the mower could slip or tip.
 - Turn slowly.
 - Turn on the most level part of the slope.
 - To maximize traction, it is better to turn the front of the mower uphill, rather than downhill. **If drive tires lose traction, steering control is lost which could cause serious injury or death.**
 - If it becomes necessary to turn downhill, turn slowly and gradually, if possible.
- ▲ Do not remove or modify the stabilizer wheels.
- ▲ Watch for holes, ruts, bumps, rocks or other hidden objects. Uneven terrain could overturn the mower. Tall grass can hide obstacles.
- ▲ Remove obstacles such as rocks, tree limbs, etc.
- ▲ Keep all movement on slopes slow and gradual. Do not make sudden changes in speed or direction.
- ▲ Avoid starting and stopping on a slope. If tires lose traction, disengage the mower blades and proceed slowly straight down the slope.
- ▲ Mow a safe distance (minimum of 10 feet) away from drop-offs, retaining walls, drainage ditches, embankments, water, and other types of hazards to avoid a wheel dropping over the edge or to avoid the ground from breaking away. This will reduce the risk of the mower suddenly rolling over causing serious injury or death.

- ▲ Use a walk-behind, push mower or hand-held trimmer on slopes and near drop-offs, retaining walls, drainage ditches, embankments and water to avoid mower rollover and serious injury or death.
- ▲ Do not mow on wet grass. Slippery conditions reduce traction which could cause sliding and loss of control.
- ▲ Do not tow on slopes. The weight of the towed equipment may cause loss of traction and loss of control.
- ▲ Do not try to stabilize the mower by putting your foot on the ground.
- ▲ If the mower's tires lose traction when operating on slopes, disengage the blades, place the steering control levers in the park brake position, stop the engine, remove the ignition switch key, and get help.
- ▲ Never make sudden starts, stops, turns, or reversals of direction, especially when maneuvering on slopes. The steering is designed for sensitive response. Rapid movement of the control levers in either direction could result in a reaction of the mower that can cause serious injury.
- ▲ Never stop suddenly while backing down slopes. This action may result in a reaction of the mower that can cause serious physical injury.
- ▲ The Hustler® mower is capable of operating horizontally (traverse) on moderately steep slopes. When operating on slopes up to 15 degrees, be aware of any conditions that may cause the mower drive tires to lose traction resulting in a possible loss of control of the mower. An operator should not operate on a slope until he is thoroughly familiar with the equipment.

Do not operate on slopes greater than 15 degrees.

Refer to the *Slope Guide*, when determining the degree of slope to be mowed.

It is strongly recommended that the operator drive the mower off of the slope slowly, using extreme caution, if any sign of loss of traction is detected. Wait until the condition that caused the problem is resolved before attempting to operate on the slope again.

Terrain conditions can affect traction resulting in possible loss of control of the mower. Some of the conditions to be aware of are:

- Wet terrain
- Depressions in the ground; i.e. holes, ruts, washouts
- Mounds of dirt
- Soil type; i.e. sand, loose dirt, gravel, clay
- Grass type, density, and height
- Extremely dry conditions of grass
- Tire pressure

Any attachments mounted to the mower will also affect the way it handles on a slope. Be aware that each attachment's characteristics vary.

Another consideration for safe mowing on slopes is to be aware of what is located at the bottom of the slope. Extreme caution should be used when there is a hazard located at the bottom of the slope. Some examples are:

- Water; i.e. lake, river
- Cliffs, retaining walls
- Roads, highways
- Buildings
- Rocks

These are just a few examples of situations when caution must be used when operating on a slope. There are many other possibilities too numerous to mention. Just remember to always exercise extreme caution when operating on any slope.

- ▲ The ROPS may minimize chance of injury or death from rollover. The seat belt **must** be fastened while operating a mower equipped with a **ROPS in the raised and secured position. Both retaining pins and hair pins must be installed.** Failure to use a seat belt with ROPS may result in serious injury in the event of a roll over.

Children

Tragic accidents can occur if the operator is not alert to the presence of children. Children are often attracted to the mower and the mowing activity. Never assume that children will remain where you last saw them.

- ▲ Never leave the mower unattended with the ignition key in the switch, especially with children present.
- ▲ Children or bystanders may be injured if they attempt to move or to operate the mower while it is unattended. Always disengage the deck clutch, place the control levers in park brake position, stop the engine, and remove the ignition key when leaving the operator's seat.
- ▲ Keep children out of the mowing area and under the watchful care of a responsible adult other than the operator.
- ▲ Be alert and turn the mower off if children enter the area.
- ▲ Before and while backing, look behind and down for small children.
- ▲ Never carry children, even with the blades off. They may fall off and be seriously injured or interfere with safe mower operation. Children who have been given rides in the past may suddenly appear in the mowing area for another ride and be run over or backed over by the mower.
- ▲ Never allow children to operate the mower.
- ▲ Never allow children or others in or on towed equipment.

- ▲ Use care when approaching blind corners, shrubs, trees, the end of a fence or other objects that may obscure vision.

Service Precautions

- ▲ Unless specifically required, **DO NOT** have the engine running when servicing or making adjustments to the mower.
 - Park the mower on level ground.
 - Disengage the deck clutch.
 - Place the steering control levers in the park brake position.
 - Lower the deck.
 - Stop the engine.
 - Remove the ignition key.
 - Disconnect the negative battery cable.
 - Wait for all movement to stop before adjusting, cleaning or repairing.
 - Repairs or maintenance requiring engine power should be performed by trained maintenance personnel only.
 - To prevent carbon monoxide poisoning, operate the engine in a well ventilated area only.
 - Read and observe all safety warnings in this manual.
- ▲ Before working on or under the deck, make certain the engine cannot be accidentally started.
- ▲ **Always** keep belt covers on mower deck for safety as well as for cleanliness except when changing or checking the belt.
- ▲ Use a stick or similar instrument to clean under the mower making sure that no part of the body, especially arms and hands are under the mower.
- ▲ Always wear adequate eye protection when:
 - servicing the hydraulic system.
 - servicing the battery.
 - grinding mower blades and removing accumulated debris.
- ▲ Never attempt to make any adjustments or repairs to the mower drive system, mower deck or any attachment while the mower engine is running or deck clutch is engaged. Repairs or maintenance requiring engine power should be performed by trained maintenance personnel only.
- ▲ Never work under the machine or attachment unless it is safely supported with jack stands.
 - Make certain machine is secure when it is raised and placed on the jack stands.
 - The jack stands should not allow the machine to move when the engine is running and the drive wheels are rotating.

- **Use only certified jack stands.** Use only appropriate jack stands, with a minimum weight rating of 2000 pounds (907 kg) to block the unit up.
- Use in pairs only.
- Follow the instructions supplied with the jack stands.
- ▲ Exercise caution when releasing spring tension from any of the belt idlers or when working with any of the deck lift components.
- ▲ Do not touch hot parts of machine.
- ▲ Keep nuts and bolts tight, especially the blade attachment bolts. Keep equipment in good working condition.
- ▲ Never tamper with safety devices. Check their proper operation regularly.
- ▲ Grass collection system components are subject to wear, damage and deterioration, which could expose moving parts or allow objects to be thrown. Frequently check components and replace with manufacturer's recommended parts, when necessary.
- ▲ Exercise caution when working under the deck as the mower blades are extremely sharp. Wrap the blade(s) or wear gloves and use extra caution when servicing them.
- ▲ Use original Hustler® replacement parts, or parts that are equivalent in overall performance, that are available from your local Hustler® Dealer.
 - The mower may not comply with the appropriate safety standards if aftermarket parts, accessories, or attachments are used.

Mower Blade Maintenance Precautions

- ▲ Never attempt to straighten a bent blade by heating, or weld a cracked or broken blade as the blade may break and cause serious injury. Replace worn or damaged blades.
- ▲ Never work with blades while engine is running or deck clutch switch is engaged (on).
- ▲ Always wear adequate eye protection when grinding mower blades.
- ▲ Mower blades are sharp and can cut. Wrap the blade(s) or wear gloves and use extra caution when servicing them.

Battery Service Precautions

- ▲ Battery posts, terminals, and related accessories contain lead and lead compounds, chemicals known to the State of California to cause cancer and reproductive harm. Wash hands after handling.
- ▲ Charge batteries in a well-ventilated open area, away from sparks and flames. Unplug charger before connecting or disconnecting from battery. Wear protective clothing and use insulated tools.

- ▲ Avoid skin and clothing contact with battery acid.
 - Always wear eye protection when checking the battery. Acid can cause serious injury to skin and eyes. If contact occurs, flush area with clean water and call a physician immediately. Acid will also damage clothing.
 - Do not drink the battery electrolyte.
 - Do not allow open flame near the battery when charging.
 - Hydrogen gas forms inside the battery. This gas is both toxic and flammable and may cause an explosion if exposed to flame. Always **disconnect** the negative (black) battery cable(s) before disconnecting the positive (red) cable(s). Always **connect** the positive (red) battery cable(s) before connecting the negative (black) cable(s).
 - Do not overfill the battery.
 - Electrolyte may overflow and damage paint, wiring or structure. When cleaning the battery, use soap and water. Be careful not to get soap and water into the battery. Clean the battery terminals with a solution of four parts water and one part baking soda when they become corroded.
- ▲ Shorts caused by battery terminals or metal tools touching metal mower components can cause sparks. Sparks can cause a battery gas explosion which will result in personal injury.
 - Prevent the battery terminals from touching any metal mower parts when removing or installing the battery.
 - Do not allow metal tools to short between the battery terminals and metal mower parts.
- ▲ Incorrect battery cable routing could cause damage to the mower and battery cables. This can cause sparks which can cause a battery gas explosion which will result in personal injury.
 - Always **disconnect** the negative (black) battery cable(s) before disconnecting the positive (red) cable(s).
 - Always **connect** the positive (red) battery cable(s) before connecting the negative (black) cable(s).

Fuel Handling Precautions

- ▲ To avoid personal injury or property damage, use extreme care in handling fuel. Fuel is extremely flammable and the vapors are explosive.
- ▲ Diesel fuel is harmful or fatal if swallowed.
- ▲ Long-term exposure to vapors can cause serious injury and illness.
- ▲ Avoid prolonged breathing of vapors.

- ▲ Keep fuel away from eyes and skin.
 - Keep face away from nozzle and gas tank or fuel container opening.
 - If fuel is spilled on clothing, change clothing immediately.

- ▲ Observe usual fuel handling precautions.
 - Do not smoke while refueling. Extinguish all cigarettes, cigars, pipes and other sources of ignition.
 - Do not remove fuel cap or fill tank with engine running or while engine is hot. Clean up any fuel spills.
 - If fuel is spilled, do not attempt to start the engine but move the machine away from the area of spillage and avoid creating any source of ignition until fuel vapors have dissipated.
 - Allow engine to cool before storing machine inside a building.
 - Keep fuel away from open flame or spark and store machine away from open flame or spark or pilot light such as on a water heater or appliances.
 - Use extreme care when handling diesel fuel and other fuels. They are extremely flammable and vapors are explosive. A fire or explosion from fuel can burn you and others and can damage property.
 - Refuel outdoors. Never refuel or drain the fuel from the machine indoors.
 - Never attempt to start engine when there is a strong odor of diesel fuel fumes present. Locate and correct cause.
 - Store fuel in an approved container and keep it out of the reach of children. Never buy more than a 30 day supply of fuel.
 - Do not fill fuel containers inside a vehicle or on a truck or trailer bed with interior carpets or plastic truck bed liners. Always place fuel containers on the ground away from your vehicle before filling.
 - When practical, remove diesel fuel powered equipment from the truck or trailer and refuel the equipment with its wheels on the ground. If this is not possible, then refuel such equipment on the truck or trailer using a portable container and not a fuel dispenser nozzle. If a fuel dispenser nozzle must be used, keep the nozzle in contact with the rim of the fuel tank or container opening at all times until fueling is complete. Do not use a nozzle lock-open device.
 - Never use gasoline or diesel fuel for cleaning parts.

- ▲ Read and observe safety precautions elsewhere in this manual.

Safety and Instructions Decals

The decals are designed to give the operator and mechanic brief daily operational and service information. Use these decals as an extension of this manual. Do not remove or obliterate the decals. Replace unreadable or missing decals.

It is the **owner's responsibility** to make certain that the operators and mechanics read and understand all decals before operating this machine.

WARNING

Specific safety warning decals are located on the equipment near the immediate areas of potential hazards. Do not remove or obliterate these decals. Replace them if they become non-readable.

The following illustrations show the safety decals that are located on the mower. A brief explanation is shown to help the operator understand the decal's meaning.



- Read Operator's Manual and Safety Warning Decals before attempting to operate this machine.



- Do not smoke while refueling.
- Do not remove the fuel tank cap or fill tank with engine running or while the engine is hot.
- Allow the mower, especially the engine, to cool in a well ventilated area before storing inside a building or other enclosure.
- Store away from open flame or spark if there is fuel in tank.
- Clean up any diesel fuel spills.
- Do not refuel while in enclosed trailer or other enclosed areas.



WARNING: Fire!

Part Number 601967

- Clean flammable material from machine. Prevent fires by keeping engine compartment, top of deck, exhaust area, battery, fuel line, fuel tank and operator's station clean of accumulated trash, grass clippings, and other debris. Always clean up spilled fuel and oil.



WARNING:
Hot surface!

Part Number 779280

- Avoid skin contact with hot surface.



DANGER: Thrown objects!

Part Number 603391

- Never operate the mower deck with the rear deflector damaged, altered, or removed.



WARNING: Thrown objects!

Part Number 601892

- Always maintain a safe distance from people and pets when mowing.
- Always stop machine if someone enters the area.
- Inspect area to be mowed for hazards such as rocks, metal objects and other debris which may be thrown or entangled by mower blades. Remove these objects before mowing.



WARNING:
Fluid under pressure!

Part Number 601968

- Avoid hydraulic fluid escaping under pressure
- Hydraulic fluid escaping under pressure can penetrate skin.
- Hydraulic fluid escaping under pressure may have sufficient force to penetrate skin and cause serious injury. Foreign fluid injected into the skin must be surgically removed within a few hours by a doctor, familiar with this form of injury, or gangrene may result.
- Before applying pressure to hydraulic system, make sure all connections are tight and all hoses and lines are in good condition.
- Relieve all pressure in the system before disconnecting or working on hydraulic lines.
- To find a leak under pressure, use a piece of cardboard or wood – never use your hands.
- To relieve all pressure in system, lower attachment and turn engine off.



WARNING:
Thrown objects!

Part Number 601624

- Never operate the mower deck with side deflector damaged, altered, removed or in raised position, except when the entire grass catcher attachment or mulching system is being used.



Part Number 601837

DANGER:
Rotating blades, pulleys & belts

- Keep shields and covers in place while machine is in operation
- Keep hands, feet and clothing away from rotating pulleys and belts.

WARNING: Thrown objects!

- Never operate the mower deck with side deflector damaged, altered, removed or in raised position, except when the entire grass catcher attachment or mulching system is being used.



Part Number 604221

DANGER:
Rotating blades, pulleys & belts

- Keep shields and covers in place while machine is in operation.
- Keep hands, feet and clothing away from rotating pulleys and belts.

DANGER: Battery Hazards!

Part Number 601815

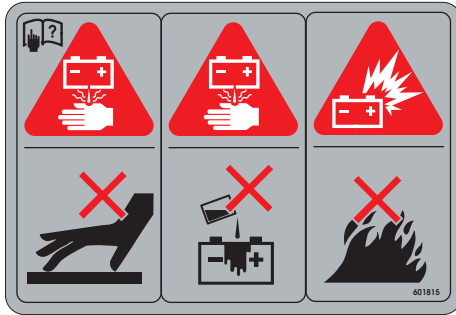

- Avoid skin contact with battery acid

- Do not overfill battery.
- Electrolyte may overflow and damage paint, wiring or structure. When cleaning the battery, use soap and water. Be careful not to get soap and water into the battery. Use soda mixed in water to clean corrosion off the terminals.
- Always wear eye protection when checking the battery, acid can cause serious injury to skin and eyes. If contact occurs, flush area with clean water and call physician immediately. Acid will also damage clothing.

- Do not allow open flame near the battery when charging.
- Hydrogen gas forms inside the battery. This gas is both toxic and flammable and may cause an explosion if exposed to flame. Always remove the negative ground first and replace it last.

Part Number 601635



WARNING: Read Operator's Manual and decals before attempting to operate this machine.

WARNING: This structure's protective capability may be impaired by structural damage, overturn, or alteration. If any of these conditions occur, this structure must be replaced.

WARNING: Roll over!

















- Avoid crushing, use seat belt.
- Do not jump if machine tips.
- To minimize chance of injury or death from rollover; keep ROPS in the raised and locked position and use the seat belt.

- Do not remove ROPS.

- Never operate machine on a slope with the ROPS folded down (lowered position).
- There is no roll over protection when the ROPS is in the lowered position.
- Lower the ROPS only when absolutely necessary. Drive slowly and carefully. Raise the ROPS as soon as clearance permits.
- Read and follow slopes operation instructions and warnings.
- Do not wear seat belt when the ROPS is in the lowered position.

WARNING: Ejection!

- Always pull from the mower hitch.
- Do not attach chains or ropes to the ROPS for pulling purposes, as the machine can tip backwards.

 	<p>Part Number 601993</p> <p>WARNING: Read operator's Manual and decals before attempting to operate this machine.</p>
 	<p>WARNING: Roll over!</p> <ul style="list-style-type: none"> • Operate a safe distance (minimum of 10 feet) away from drop-offs, retaining walls, drainage ditches, embankments, water, and other types of hazards to avoid a wheel dropping over the edge or to avoid the ground from breaking away.
  	<p>WARNING: Back over!</p> <ul style="list-style-type: none"> • Do not carry passengers. • Always stop machine if someone enters the area. • Always be aware of what is behind the machine before backing up. Do not mow in reverse unless absolutely necessary. Always look down and behind before and while backing up.
   	<p>WARNING: Roll over!</p> <ul style="list-style-type: none"> • Slow down before turning. • Do not operate on slopes greater than 15 degrees. • Keep all movement on slopes slow and gradual. Never make sudden changes in speed and direction. • Do not operate on slopes above a retaining wall or drop-off.
  	<p>WARNING: Ejection!</p> <ul style="list-style-type: none"> • Do not operate on slopes greater than 15 degrees. • Keep all movement slow and gradual when going up or down slopes. • Do not remove or modify stabilizer wheels or injury can result.
  	<p>WARNING: Loss of traction/control on slopes!</p> <ul style="list-style-type: none"> • Shut off blades. • Back slowly down the slope when loss of traction occurs.



Caution: Add engine oil slowly. Pouring the oil too quickly may damage the engine.

SEE ENGINE OWNER'S MANUAL

Part Number 606453

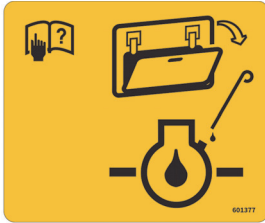

- Read Operator's Manual.
- Open shield.
- Check oil level on dip stick.

Part Number 601377

<p>WARNING: Thrown objects!</p> <ul style="list-style-type: none"> • Always maintain a safe distance from people and pets when mowing. • Always stop machine if someone enters the area. • Inspect area to be mowed for hazards such as rocks, metal objects and other debris which may be thrown or entangled by mower blades. Remove these objects before mowing. 	<p>Part Number 604222</p>	<p>DANGER: Rotating blades, pulleys & belts</p> <ul style="list-style-type: none"> • Keep shields and covers in place while machine is in operation. • Keep hands, feet and clothing away from rotating pulleys and belts.
---	----------------------------------	---



WARNING: Hot surface!

Part Number 602041

- Keep a safe distance from the machine.

Top of Deck Clutch Switch Shown

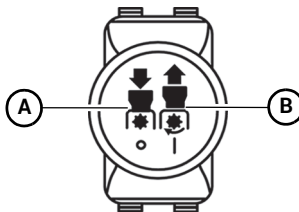

- A. Deck clutch disengaged (OFF) position
- B. Deck clutch engaged (ON) position



Part Number 600899

- If you lose steering control while operating the machine, place the steering control levers in the park brake position immediately. Inspect the machine and involve your dealer to resolve the problem before continuing to operate.
- If pump belt fails, steering control will be lost. Refer to owner's manual for inspection and replacement intervals and refer to above paragraph for emergency procedures.

Part Number 603363

This power lawn mower is manufactured in accordance with the applicable ANSI B71.1 or B71.4 standard

- This power lawn mower is manufactured in accordance with the applicable ANSI B71.1 or B71.4 standard.

Part Number 601908



WARNING: Fire

- Operation of this equipment may create sparks that can start fires around dry vegetation. A spark arrester may be required. The operator should contact local fire agencies for laws or regulations relating to fire prevention requirements.

Used on mowers with Non Tier 4 engines

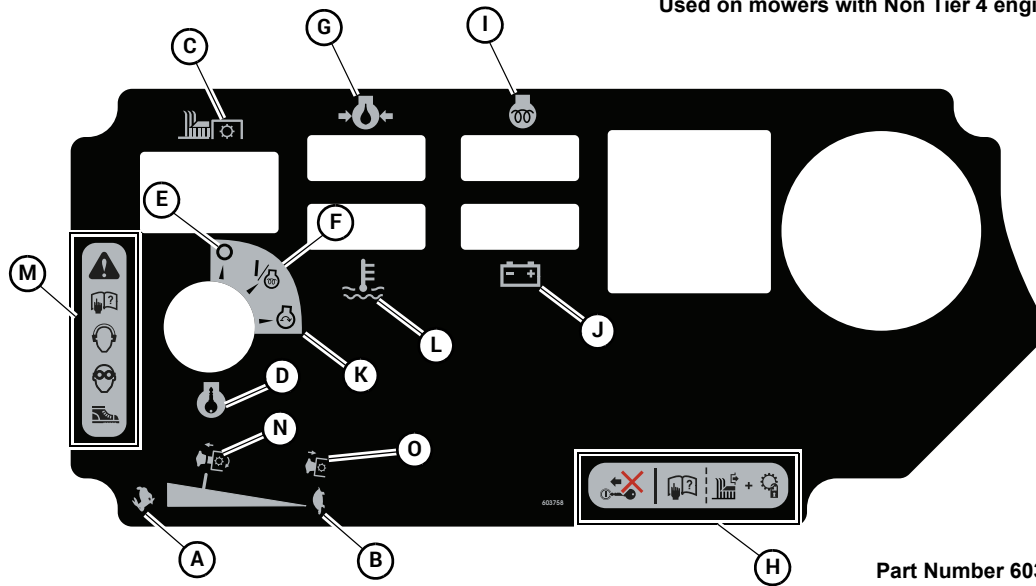

Part Number 603758

- C. Fast
- D. Slow
- E. Mower blade engage/disengage switch
- F. Ignition switch - insert key
- G. OFF
- H. ON/GLO Plug
- I. If warning light comes on, check engine oil
- J. Before starting the engine:
 - Read Operator's Manual
 - Disengage mower blades
 - Place control levers in park brake position
- K. GLO-plug
- L. If warning light comes on, check charging system
- M. Engine start position
- N. If warning light comes on, engine coolant at unsafe temperature
- O. Read Operator's Manual before attempting to operate this machine. Wear ear protection, eye protection and safety shoes when operating this equipment.
- P. Clutch engage
- Q. Clutch disengage

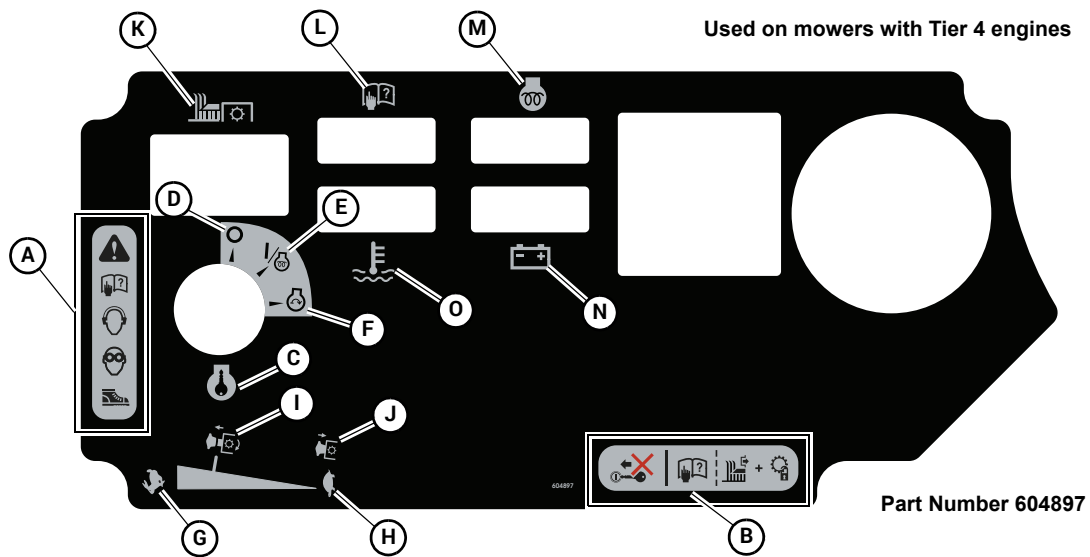

- | | |
|--|--|
| <p>A. Read Operator's Manual before attempting to operate this machine. Wear ear protection, eye protection and safety shoes when operating this equipment.</p> <p>B. Before starting the engine:</p> <ul style="list-style-type: none"> • Read Operator's Manual • Disengage mower blades • Place control levers in park brake position <p>C. Ignition switch - insert key</p> <p>D. OFF</p> <p>E. ON/GLO Plug</p> <p>F. Engine start position</p> | <p>G. Fast</p> <p>H. Slow</p> <p>I. Clutch engage</p> <p>J. Clutch disengage</p> <p>K. Mower blade engage/disengage switch</p> <p>L. Read Operator's Manual before attempting to operate this machine</p> <p>M. GLO-plug</p> <p>N. If warning light comes on, check charging system</p> <p>O. If warning light comes on, engine coolant at unsafe temperature</p> |
|--|--|

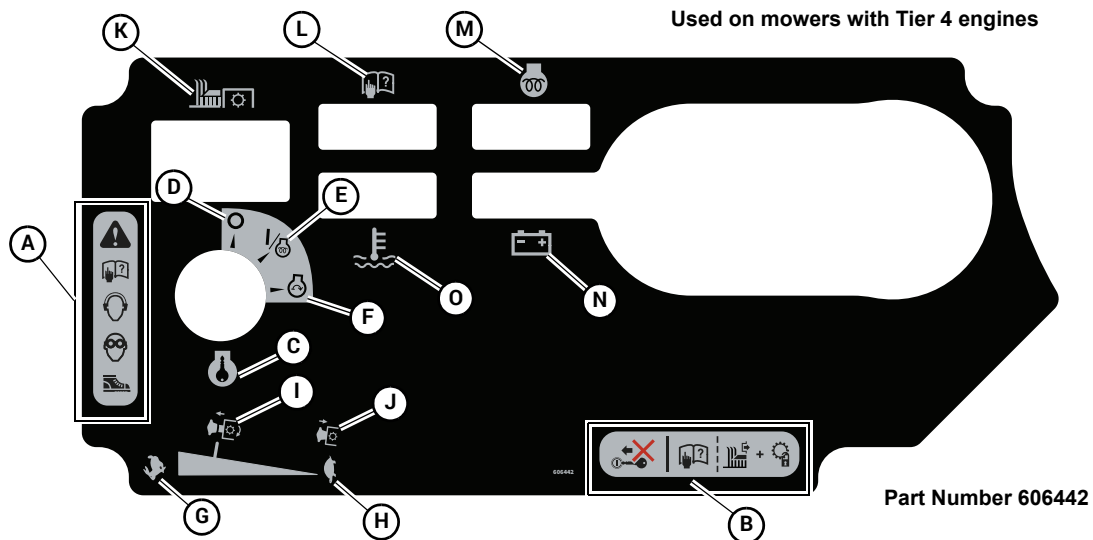

- | | |
|--|--|
| <p>A. Read Operator's Manual before attempting to operate this machine. Wear ear protection, eye protection and safety shoes when operating this equipment.</p> <p>B. Before starting the engine:</p> <ul style="list-style-type: none"> • Read Operator's Manual • Disengage mower blades • Place control levers in park brake position <p>C. Ignition switch - insert key</p> <p>D. OFF</p> <p>E. ON/GLO Plug</p> <p>F. Engine start position</p> | <p>G. Fast</p> <p>H. Slow</p> <p>I. Clutch engage</p> <p>J. Clutch disengage</p> <p>K. Mower blade engage/disengage switch</p> <p>L. Read Operator's Manual before attempting to operate this machine</p> <p>M. GLO-plug</p> <p>N. If warning light comes on, check charging system</p> <p>O. If warning light comes on, engine coolant at unsafe temperature</p> |
|--|--|

Slope Guide

Use this diagram when determining the degree of slope to be mowed.

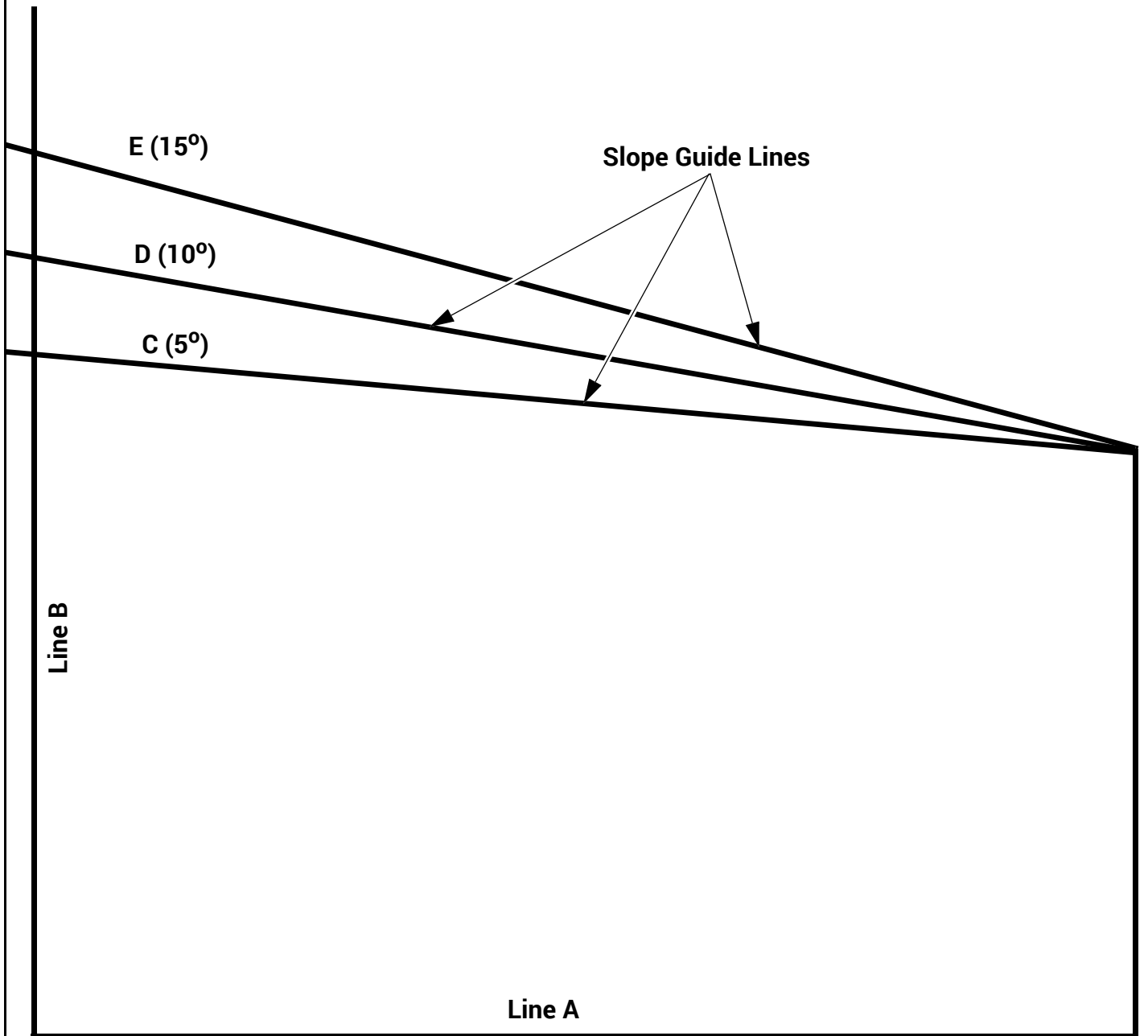

1. Hold this sheet of paper in front of you. Make sure that Line A is horizontal.
2. Align Line B with a vertical surface such as pole, tree or building.
3. Fold the paper along the slope guide lines (C, D or E).
4. Align the closest slope guide line with the ground slope. This will give you a close estimation of the ground slope to be mowed.

OPERATION

Safe Operating Practices

Refer to the Safety Precautions section of this manual for operational and personal safety information.

Control Panel

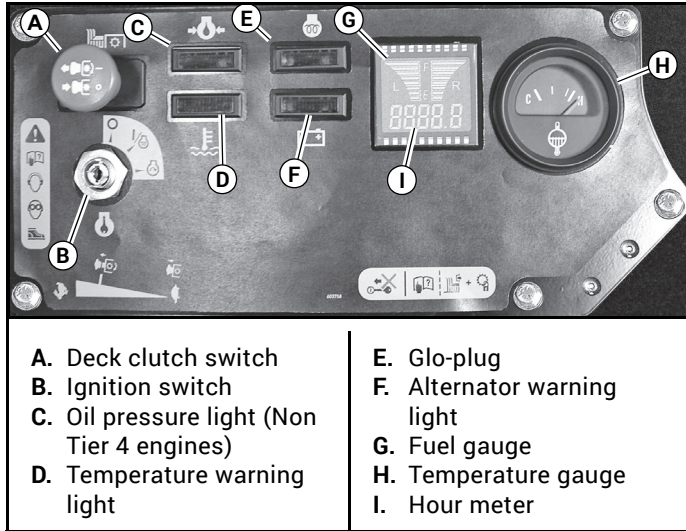

Figure 3-1

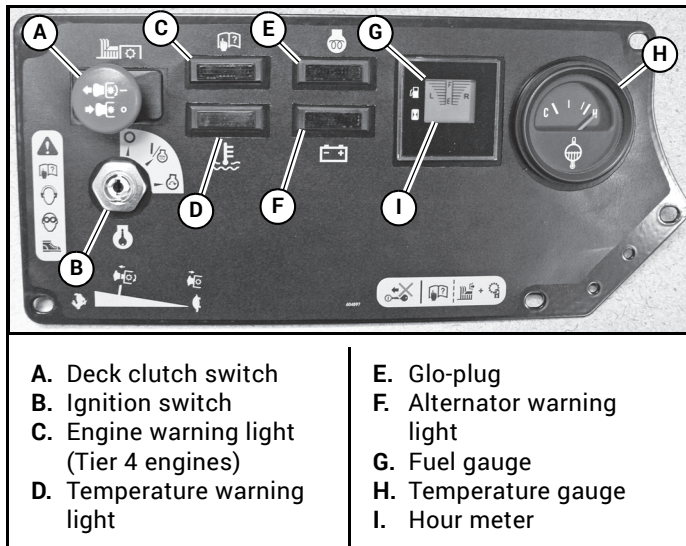

Figure 3-2

IMPORTANT: When access is required under the seat platform and the seat is equipped with the optional arm rests, make certain to place the control arms in the park brake position and pivot the arm rests upward before placing the seat platform in the full forward position to prevent arm rest damage.

A. Deck clutch switch (Figure 3-1, Figure 3-2, Figure 3-3) – this switch engages the deck. Pull the switch up to engage and push switch down to disengage the clutch.

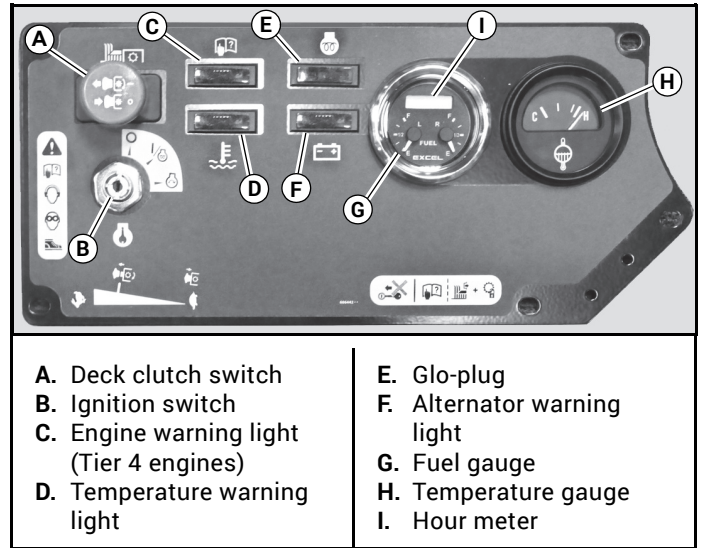

Figure 3-3

IMPORTANT: For additional clutch information refer to the Mower deck operation section of this manual.

B. Ignition switch (Figure 3-1, Figure 3-2, Figure 3-3) – a three position switch: “OFF”, “PREHEAT/RUN”, and “START”. With key inserted, rotate it clockwise to “PREHEAT/RUN” position. After pre-heat has occurred, rotate the key to the “START” position; release key when engine starts, and switch will automatically return to the “RUN” position.

C. Oil pressure light (Figure 3-1) – (Non Tier 4 engines only) this light comes on when the ignition switch is placed in the RUN position and stays lit until the engine is running and a safe oil pressure is developed. If light comes on during operation, shut engine off immediately and locate and correct the problem.

Engine warning light (Figure 3-2, Figure 3-3,) – (Tier 4 engines only) This light will flash once during engine starting to show that the system is operating properly. This light will also begin to flash an error code when a problem is detected by the engine controller. Refer to the Hustler® Z Diesel General Service Manual (P/N 115164) for additional information.

D. Temperature warning light (Figure 3-1, Figure 3-2, Figure 3-3) – this light will come on when the engine coolant temperature reaches an unsafe level during operation. If light comes on, shut down the machine as soon as possible. Never risk continued operation when light remains on; high temperatures can severely damage the engine.

E. Glo-plug light (Figure 3-1, Figure 3-2, Figure 3-3) – this light comes on when the ignition switch is turned to the “Pre-Heat/Run” position and held. It shows that power is going to the glo-plugs.

F. **Alternator warning light** (Figure 3-1, Figure 3-2, Figure 3-3) – this light comes on when the ignition switch is placed in the RUN position and stays lit until the engine is running and the battery is being charged. If light comes on during operation, shut engine off immediately, locate and correct the problem.

If the light remains on while the engine is running, it indicates that the battery is being discharged.

G. **Fuel tank gauge** (Figure 3-1, Figure 3-2, Figure 3-3, Figure 3-4, & Figure 3-5) – This gauge shows the fuel level for each fuel tank. The right gauge indicates the fuel level in the right fuel tank and the left gauge indicates the fuel level in the left fuel tank.

H. **Temperature gauge and alarm** (Figure 3-1, Figure 3-2, Figure 3-3) – this gauge reflects the engine coolant temperature. If the coolant reaches an unsafe level during operation, shut down the machine as soon as possible.

An audible alarm will sound when the engine coolant is close to overheating.

IMPORTANT: Never risk continued operation when the gauge needle is in the high range or the light remains on: high temperatures can severely damage the engine.

I. **Electronic hour meter** (Figure 3-1, Figure 3-2, Figure 3-3) – registers 1/10 hour increments up to 9,999.9 total hours. Connected to the ignition switch, the meter records the accumulative time while the ignition key is switched to the RUN position.

J. **Throttle control** (Figure 3-6) – a cable is linked to the engine throttle for controlling engine speed. Move lever forward to increase engine rpm, move lever rearward to decrease engine rpm.

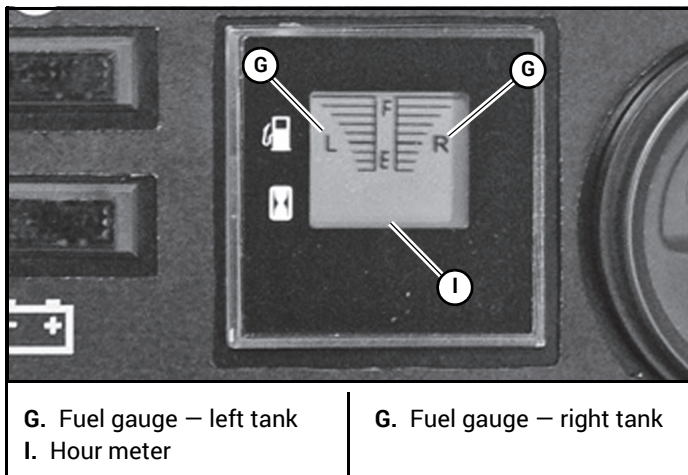

Figure 3-4

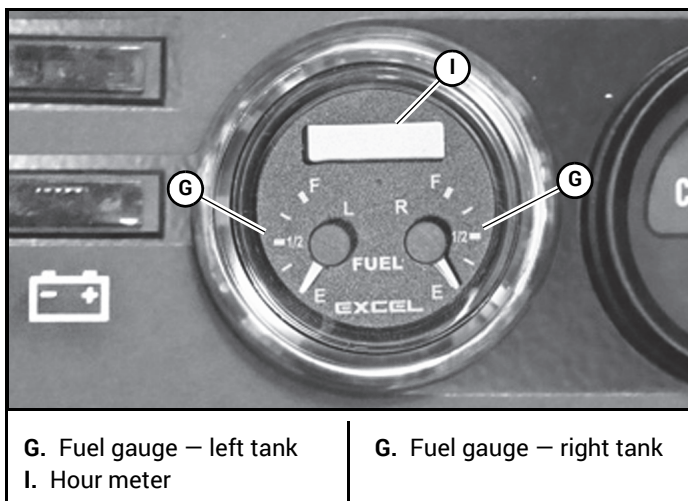

Figure 3-5



Figure 3-6

K. **15 amp fuse** (Figure 3-7) – Ignition system & safety system - 15 amp blade type. (This fuse can be found behind the access cover located behind the seat.)

L. **25 amp fuse** (Figure 3-7) – system controller - 25 amp blade type. (This fuse can be found behind the access cover located behind the seat.)

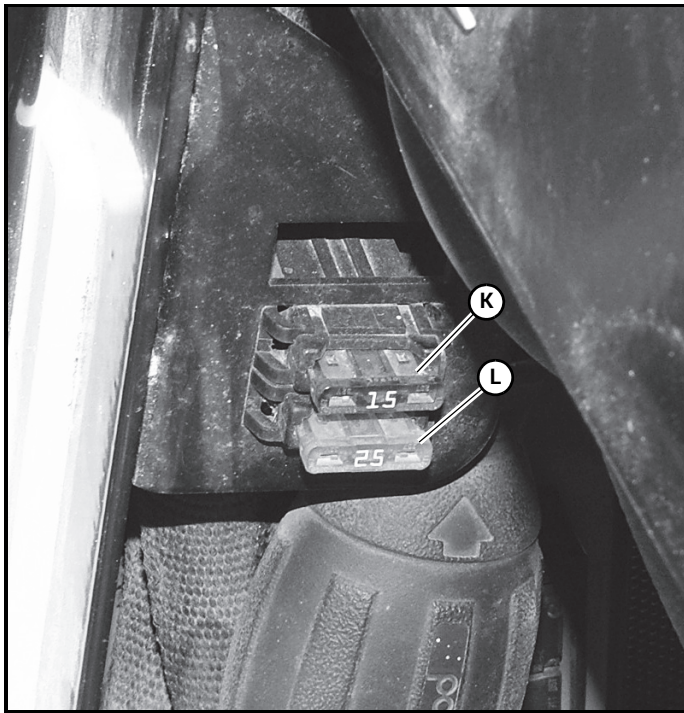

K. 15 amp fuse

L. 25 amp fuse

Figure 3-7

Shown with steering control levers in neutral position

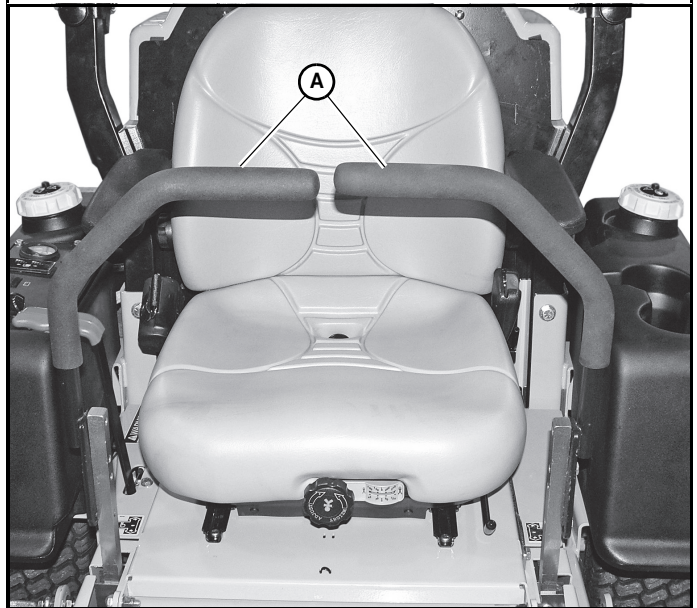

A. Steering control lever

Figure 3-8

Shown with steering control levers in park brake position

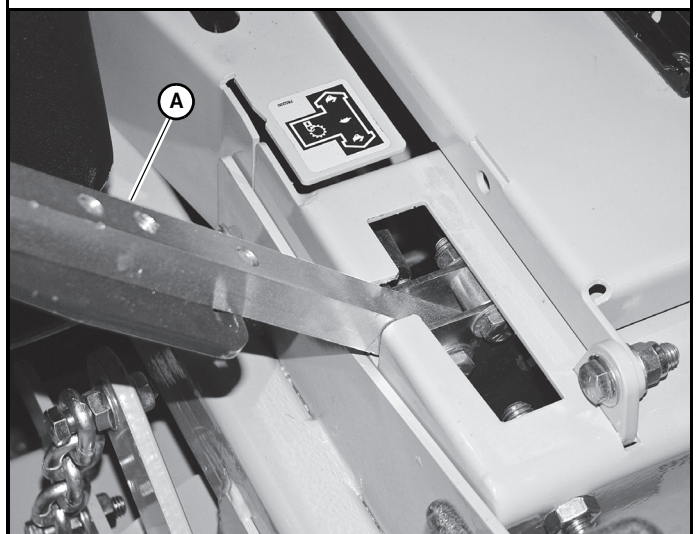

A. Steering control lever

Figure 3-9

Controls

- A. **Steering control levers (Figure 3-8 & Figure 3-9)** – these levers control the mower’s speed, direction, stopping, and park brake. These levers are used to steer, accelerate, decelerate and change direction. When the steering control levers are in the park brake position the mower will not move when the engine is on and drive pumps are operating.

WARNING ⚠

The parking brake may not hold the mower if parked on a slope. Block or chock the machine when parked on a slope.

- B. **Deck lift pedal (Figure 3-10)** – the deck lift pedal is used to raise or lower the deck. Push on the pedal to raise the deck and then place the deck height locking pin into the desired cutting height hole.

Push the deck lift pedal to raise the deck when going over obstructions.

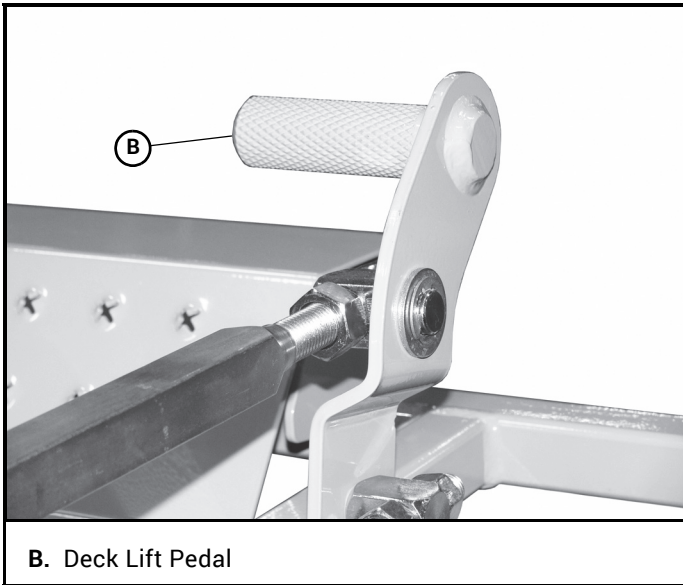

Figure 3-10

Safety Start Interlock System

The mower's safety start interlock system consists of the park brake switches, seat switch, and deck clutch switch.

IMPORTANT: Repair this important safety feature immediately if it malfunctions.

This safety feature prevents mower runaway or accidental entanglement during operation.

Check the mower's safety start interlock system daily, prior to operation.

To inspect the system:

1. Sit on the seat when testing the seat switch.
2. Set both steering control levers in the park brake position.
3. Start the engine and allow it to warm up to operating temperature.
4. With the deck clutch switch down and the steering control levers in the park brake position, slowly rise off of the seat. **The engine should continue to run.**
5. With the deck clutch switch up and/or the steering control levers in the neutral position, slowly rise off of the seat. **The engine should stop.**
6. **If the engine fails to stop when:**
 - the deck clutch switch is up, or
 - one or both of the steering control levers is in the up (out of neutral position), and
 - the operator is off the seat, then
 - check the function of the seat switch. Replace the seat switch if it is not operating properly (**is not opening or closing**) and if the cause can not be determined.

If you cannot locate the problem contact your Hustler® Dealer.



The safety interlock system should always function per steps 4 and 5. If it does not function properly, correct it immediately. Do not operate machine without a properly functioning seat safety switch.

Engine Starting

This mower safety start interlock system is designed to protect the operator and others from accidental injury due to unintentional engine starting. The engine starting motor will not engage until:

1. Steering control levers are in the park brake position.
2. Deck clutch switch is in the down (OFF) position.



The safety interlock system must not be disconnected or bypassed. Doing so could cause the machine to operate unexpectedly resulting in personal injury.

NOTE: The operator's seat is equipped with a separate safety switch. If for any reason the operator should become unseated when the brake switches are disengaged or the deck clutch switch is engaged the engine will stop.

Start the engine by following these steps. If you encounter difficulty, contact your Hustler® Dealer.

1. Make sure the control levers are in the park brake position and deck clutch switch is disengaged. Only start the engine from the operator's position.
2. Set throttle at approximately 1/2 open position.
3. Insert key in ignition switch and rotate it to the "PREHEAT/RUN" position. It takes two seconds before the glo-plug light will come on. Wait for the glo-plug light to go off (6 seconds) before rotating the key to the "START" position. This is necessary only when the temperature is below 50°F (10°C). This operation is not necessary when restarting a warm engine.

Shown in the chart are the standard preheating times for various temperatures. This operation, however, is not required when the engine is warmed up.

Failure to follow these recommendations can lead to premature failure of the starter motor and the fuel shut-off solenoid.

IMPORTANT: Ether, or other starting fluids, must never be used as a starting aid with this engine. Warranty will be denied when engine damage results from such use.

Ambient temperature	Preheating time Ordinary heat type
Above 50°F (10°C)	No need
50° (10°C) to 23°F (-5°C)	6 seconds (One cycle)
Below 23°F (-5°C)	12 seconds (Cycle glo-plugs twice)

4. Rotate ignition switch key full clockwise to engage starting motor. Release key when engine starts.

IMPORTANT: The engine starter should not be operated for periods longer than 30 seconds at a time. An interval of at least two minutes should be allowed between such cranking periods to protect the starter from overheating and burn-out.

5. Perform test to make sure safety start interlock system is operating properly. Refer to *Safety start interlock system* section.
6. As soon as engine begins to run, check to make certain the oil warning light is off. If not, stop engine immediately and check for the cause.
7. Allow the engine to idle a few minutes before advancing the throttle and/or engaging the deck clutch.

Stopping the Engine

Use the following procedure to shut the engine off.

1. Place the steering control levers in the park brake position.
2. Throttle the engine back to low idle, then disengage the deck clutch. Refer to the *Mower Deck Operation* section for more details.
3. Let the engine run at low idle for two minutes.
4. Rotate the ignition key counter-clockwise to the "OFF" position. Remove the key from the switch before leaving the mower.

Moving the Mower with Stalled Engine

If it becomes necessary to move the mower when the engine is inoperative, the hydraulic pumps are equipped with bypass valves.

Before moving the unit, turn bypass valves counter clockwise one-half to one revolution. The valve on each hydraulic pump is located near the top and is identified as a hex stud. Figure 3-11

The steering control levers must be placed in the neutral position, to release the park brakes, so that the mower can be moved.

Do not tow the machine. Move it by hand or use a winch to load on a trailer for transporting.

When transporting on another vehicle, the mower should be facing forward and it must be secured.

IMPORTANT: Always make certain the two bypass valves are returned to their operating position before running the mower following repairs. Figure 3-11

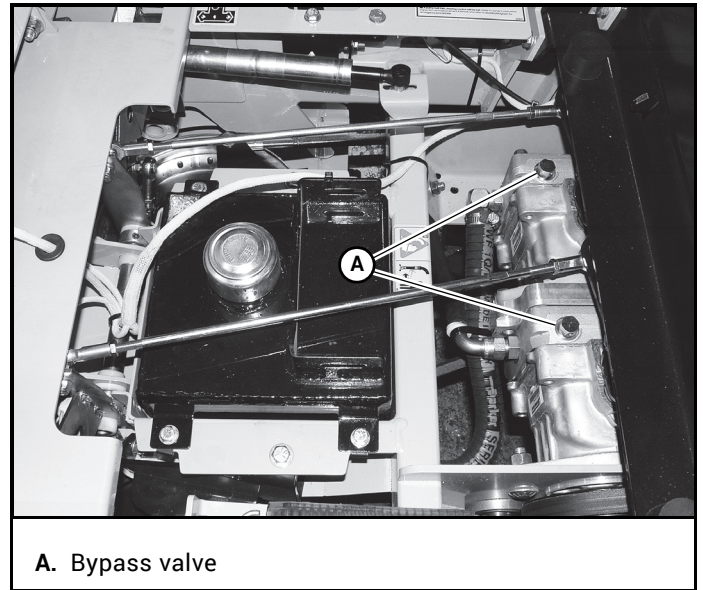

A. Bypass valve

Figure 3-11

ROPS (Roll Over Protective Structure)

A ROPS may minimize the chance of injury or death from rollover.

A ROPS, when used with a seat belt, is effective in reducing injuries during unit overturn accidents. Overturning the unit without a ROPS or without the ROPS locked in the raised position (Figure 3-12) can result in serious injury or death.

Pivot the two-post ROPS down by removing the right and left hair pins (Figure 3-12), and pulling out on the spring loaded pins to allow the machine to operate under low hanging tree limbs or other obstructions.

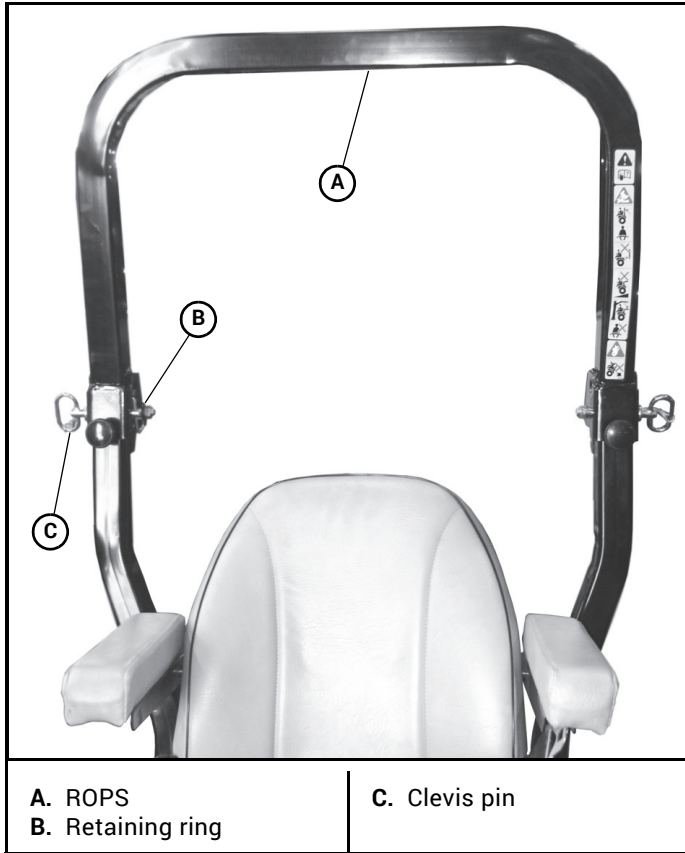

Figure 3-12

When the ROPS is locked in the raised position make sure the hair pins are inserted into the holes in the end of the spring loaded pins.

Do not wear the seat belt when the ROPS is in the lowered position. **Use the ROPS in the “folded” position only when absolutely necessary.**

WARNING Do not operate the mower with the ROPS folded down (lowered position) as a standard operating mode. A folded down ROPS does not provide rollover protection.

WARNING Always wear your seat belt unless the mower is not equipped with a ROPS or if the ROPS is folded down. In this case, the seat belt should never be worn.

WARNING

To minimize chance of injury or death from rollover:

- Keep ROPS in the raised and locked position and use the seat belt.
- Never operate the machine on a slope with the ROPS folded down (lowered position).
- There is no roll over protection when the ROPS is in the lowered position.
- Lower the ROPS only when absolutely necessary. Drive slowly and carefully. Raise the ROPS as soon as clearance permits. Read and follow slope operation instructions and warnings.
- Do not wear seat belt when the ROPS is in the lowered position or if it is not equipped with one.

WARNING

- Do not attach chains or ropes to the ROPS for pulling purposes, as the machine can tip backwards.
- Always pull from the mower hitch.

Always fasten the seat belt during mower operation (mower equipped with a ROPS in the “raised/up” position).

Inspect the area prior to mowing for proper overhead clearance (tree limbs, guy wires, doorways, etc).

Do not contact any overhead object with the ROPS.

Seat Belt Maintenance

Inspect the seat belt system (all seat, seat belt parts, and seat platform) daily prior to mowing for signs of any damage. Replace any parts with signs of:

- cuts,
- fraying,
- extreme or unusual wear,
- significant discoloration due to UV exposure,
- dirt or stiffness,
- abrasion to the seat belt webbing,
- damage to the buckle, latch plate or hardware,
- any other problem.

Use soap and water to clean the seat belt. Do not use carbon tetrachloride, naphtha, or other chemical cleaning agents, as these will weaken the webbing. For the same reason, do not bleach or dye the webbing. Replace the seat belt if worn or damaged.

Possible Damage to ROPS

If the unit has rolled over or the ROPS has been in some other type of accident (such as hitting an overhead object during transport), replace the ROPS to retain the best protection.

Following an accident, check the ROPS, the operator's seat, the seat belt, seat belt mountings and seat platform for possible damage. Before operating the machine, replace all damaged parts.

IMPORTANT: Do not attempt to weld or straighten the ROPS.

WARNING  **The ROPS structure's protective capability may be impaired by structural damage, overturn or alteration.** Do not remove or alter any of the ROPS parts. Do not attempt to weld or straighten ROPS. Failure to adhere to these instructions could result in severe injury or death.

WARNING  If the ROPS is replaced, make sure to use the proper hardware and apply the recommended torque values to the attaching bolts.

ROPS Inspection

Inspect the ROPS after the first 20 hours of operation. Following the initial inspection, check the ROPS after every 500 hours of operation or every six months, whichever comes first.

1. Check the torque of the ROPS mounting bolts (Figure 3-13). Tighten the bolts to the correct torques as shown below if necessary.
2. Inspect the operator's seat and the mounting parts for the seat belt. Tighten the bolts to the correct torque as shown below if necessary and replace parts that show wear or damage.
3. Check the seat platform to make sure it is secured properly. Adjust or repair it as necessary.

WARNING  Never operate the mower with the seat platform improperly secured. The seat platform must be properly secured to prevent the seat from moving/tilting in the event of the mower tipping or rollover.

Torque values:

	ft-lbs	N•m
ROPS mounting hardware	73.	99
Seat belt mounting hardware	48.	65

Mower Operation

This mower features the SmoothTrak™ steering system. The following provides you with detailed information on how to operate the mower efficiently.

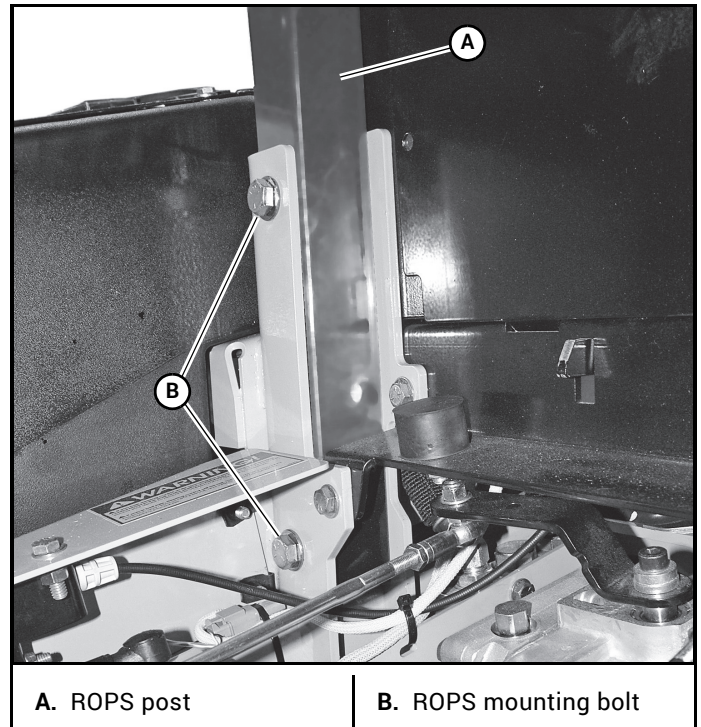



Figure 3-13

Driving the Mower

DANGER  Never make sudden stops or reverse direction, especially when maneuvering on a slope. The steering is designed for sensitive response. Rapid movement of the control levers in either direction could result in a reaction of the mower that can cause serious injury.

After starting the engine, engage the steering control levers and steer as follows:

To go forward, push the steering control levers forward an equal distance. Figure 3-14

To go in reverse, pull the steering control levers rearward an equal distance. Figure 3-14

To turn left, move the right steering control lever farther forward from neutral than the left steering control lever.

To turn right, move the left steering control lever farther forward from neutral than the right steering control lever. Figure 3-14

Zero radius turn, move one steering control lever forward and the other steering control lever back of neutral. This allows the drive wheels to counter-rotate. Figure 3-14

To stop or decrease speed, move steering control levers to neutral. When going forward pull back gently on steering control levers. When going in reverse push forward gently on steering control levers.

For **emergency stops**, when traveling forward or rearward, place the steering control levers in the park brake position immediately.

DANGER

When moving in the rearward direction push forward gently on steering control levers and avoid sudden movement. Any sudden movement could cause the front of the mower to come off of the ground resulting in possible loss of control, causing serious injury or death.

To make a three point turn to the right:

1. Move the left steering control lever farther forward from neutral than the right steering control lever and start the turn. Figure 3-15
2. Next, pull back on the steering control levers until they pass neutral and the machine starts to go rearward. Figure 3-15
3. Pull the right steering control lever farther rearward from neutral than the left steering control lever until the rear of the machine pivots around. Figure 3-15
4. Then, push the steering control levers forward until they both pass neutral and the machine starts to go forward. Figure 3-15
5. Push the left steering control lever farther forward from neutral than the right steering control lever and finish the turn. Figure 3-15

WARNING

Always be aware of what is behind the machine before backing up. Do not mow in reverse unless absolutely necessary. Always look down and behind before and while backing up.

IMPORTANT: Damage to the hydraulic system components may occur with rapid movement of the steering controls.

To **increase speed**, increase the steering control lever's distance from neutral. The farther forward the steering control levers are from neutral, the faster the mower will travel forward. The farther back the steering control levers are from neutral, the faster the mower will go in reverse.

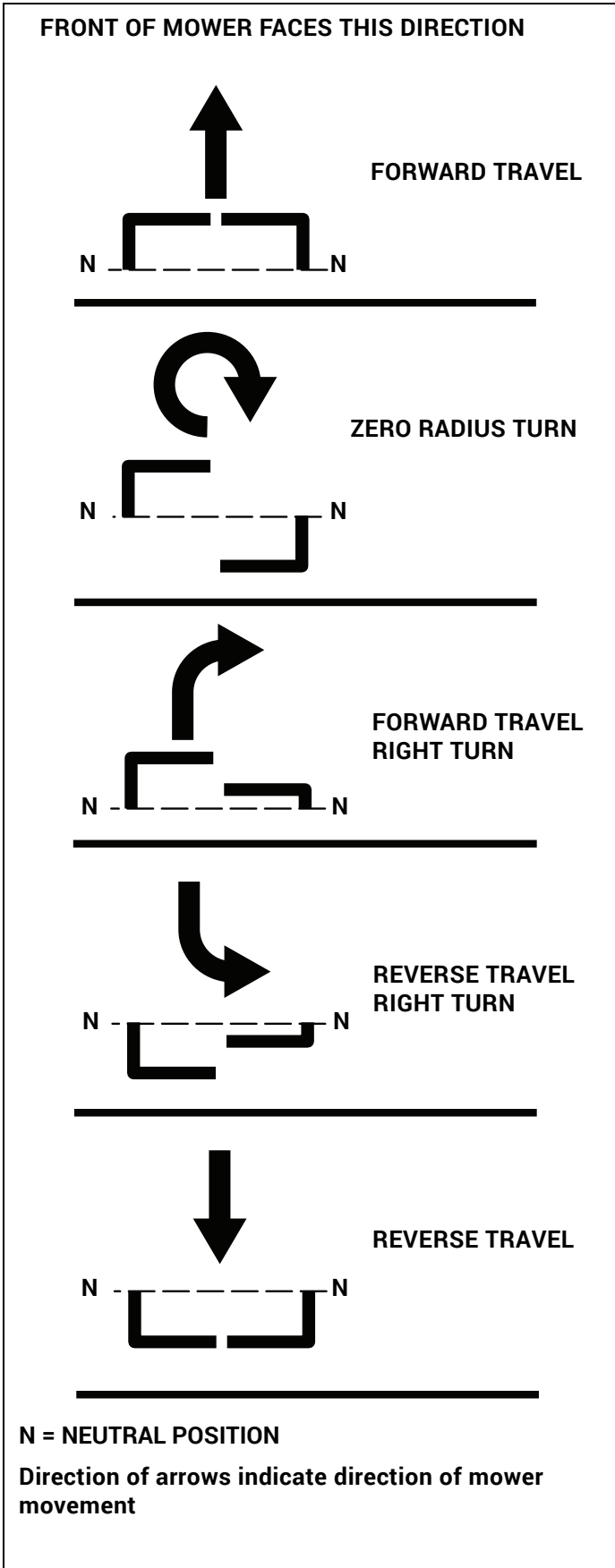

Figure 3-14

THREE POINT TURN

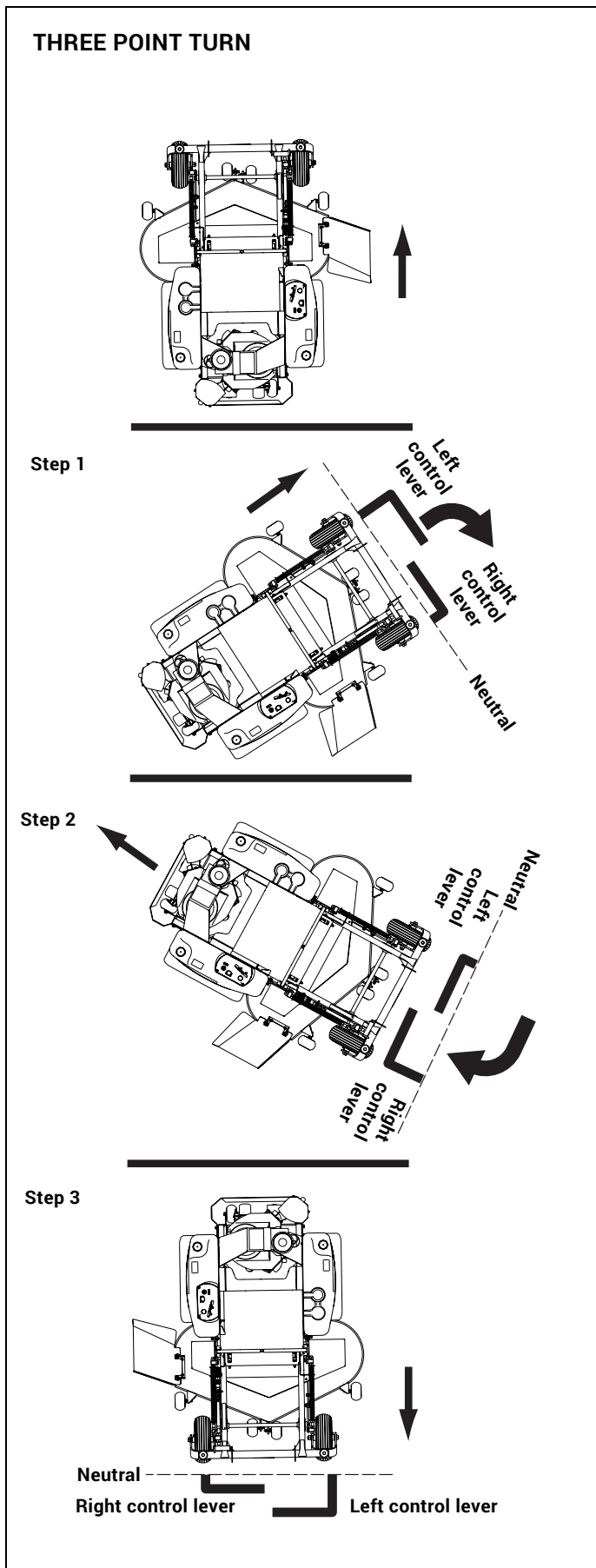

Figure 3-15

Operating Suggestions



⚠ DANGER

An inexperienced operator should not mow on slopes or on uneven terrain.

Before attempting normal speed operation an inexperienced operator should:

- be thoroughly familiar with the proper use and operation of the equipment.
- read the manual completely and thoroughly.
- have attempted slow moving maneuvers.



⚠ WARNING

If you lose steering control while operating the machine, place the steering control levers in the park brake position immediately. Inspect the machine and involve your Hustler® Dealer to resolve the problem before continuing to operate.



⚠ WARNING

The unit's steering control levers are very responsive: Easy does it! For smooth operation, move the levers slowly, avoiding sudden movement. Skill and ease of operation come with practice and experience. The machine can spin very rapidly. Use caution when making turns and slow down before making sharp turns.

Inexperienced operators may have a tendency to oversteer and lose control. Practice slow maneuvers at low engine rpm (idle) on a flat open area before attempting normal speed operation.



⚠ WARNING

Sharp depressions or raised obstacles (such as gutters or curbs) should not be directly approached at high speed in an attempt to "jump" them as the operator could be thrown from the equipment. Approach at a slow speed and angle one drive wheel at the obstruction. Continue at an angle until the wheel clears and then pivot the opposite wheel around.

When turning on soft wet turf, keep both wheels rolling either forward or backward. Pivoting on one stopped wheel can damage turf, especially when mowing.

Set the throttle at full rpm for maximum performance. This gives maximum power to the drive wheels and deck when needed. The throttle setting directly controls blade speed. Use the control levers to control ground speed rather than engine rpm.

Keep blades sharp. Many problems with incorrect cutting patterns are **due to dull blades** or blades which have been **sharpened incorrectly**. Information on sharpening blades is listed in this manual's maintenance section. **Blade sharpness should be checked daily.**

⚠ DANGER

Never work with blades while the engine is running or deck clutch switch is engaged (on).

Always place the deck clutch switch in the disengaged position, place steering control levers in the park brake position, turn the engine off and disconnect the negative battery cable.

Block the mower up when you must work under it.

Wear gloves when handling blades.

Always check for blade damage if the mower strikes a rock, branch or other foreign object during mowing!

Side Discharge Deck – Direct grass discharge to the right, away from the unmowed area. Generally, this means using a pattern of **left turns**. Avoid throwing grass discharge onto unmowed area. Mowing clippings puts an unnecessary load on the unit and reduces mowing efficiency.

When mowing a lawn for the first time cut grass slightly longer than normal to avoid scalping uneven terrain. When cutting grass taller than six inches, you may want to mow the lawn twice to achieve a better quality of cut.

During normal mowing cut only about 1/3 of the grass blade.

Alternate the mowing direction to keep the grass growing straight and for better dispersion of the clippings.

Remember, grass grows at different rates at different times of the year. Mow more often in the early spring to maintain the same cutting height. As the growth rate slows in midsummer, mow less frequently. If you cannot mow at a regular interval, mow at a high cutting height; then mow again two days later at a lower cutting height.

Raise the cutting height of the mower if the cutting width of the mower is wider than the previous mower. This ensures that uneven turf is not cut too short.

Raise the cutting height of the mower if the grass is slightly taller than normal or if it contains a high degree of moisture. Then mow it again with the cutting height set lower.

If the machine's forward motion must be stopped while mowing, a clump of grass clippings may drop onto your lawn. To avoid this, move onto a previously cut area with the blades engaged.

⚠ WARNING

Side Discharge Decks – Never direct the discharge of material from the mower deck toward bystanders.

- Never operate the mower deck with the discharge chute damaged, altered, removed, or in the raised position, except when the entire grass catcher attachment or mulching system is being used. Figure 3-16

Discharge chute may vary from this illustration

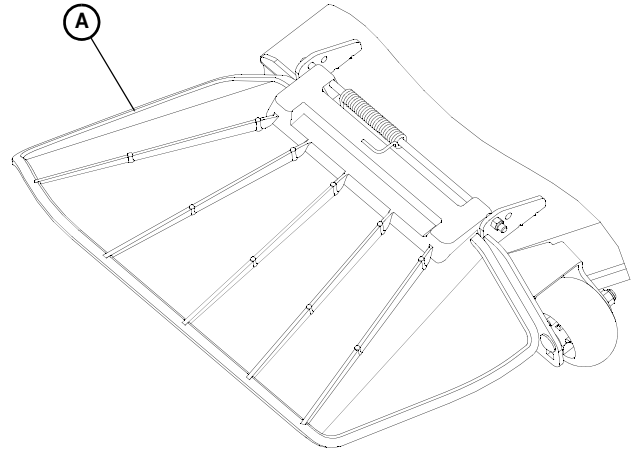

A. Discharge chute

Figure 3-16

⚠ DANGER

Rear Discharge Decks – Never direct the discharge of material from the mower deck toward bystanders. Do not operate the mower without the rear discharge rubber flaps or power unit deflector in place. Figure 3-17

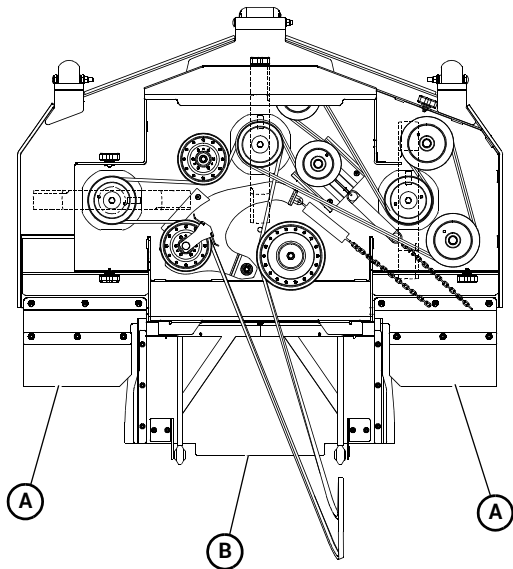

A. Rubber flaps

B. Deflector guard

Figure 3-17



Never attempt to make any adjustments to the mower deck while the engine is running or with the deck drive clutch engaged. Mower blades cannot be seen and are located very close to the deck housing. Fingers and toes can be cut off instantly.

Flex Forks®

New Flex Forks® require a brief break-in period. Refer to the *Maintenance and Adjustments* section of this manual for more details.

Deck Clutch Operation

Before beginning operation, check to make sure the deck clutch switch is engaging and disengaging the blades properly.



Make sure that the area around and under the deck is clear and that there are no bystanders in the immediate area before proceeding.

To check the deck clutch switch:

1. Start the engine and engage the deck clutch.
2. With the deck clutch switch up (clutch engaged) and the engine running, listen to confirm that the mower blades are rotating.
3. Now, push the deck clutch switch down (clutch disengaged), and with the engine running, listen to confirm that the blades have stopped rotating.
4. If the mower blades continue to rotate with the deck clutch switch down, discontinue operation immediately and contact your Hustler® Dealer.

Follow these procedures to maximize clutch life:

1. **Engage the clutch** only when the throttle is set at approximately **2/3 throttle** and there is **no load** on the blades. After clutch engagement, advance the engine throttle to full rpm.

Engaging the deck clutch at high engine rpm or when under heavy load (in tall grass, for example) can cause belts and/or electric clutch to slip, resulting in premature wear or possible damage.

2. **Disengage the clutch** only when the throttle is set at **less than 1/2 throttle**.

Never disengage the clutch with the engine running at high rpm. Setting the throttle to less than 1/2 throttle when disengaging the clutch will help extend clutch life.

Warranty will not be allowed for deck clutches that fail due to improper engagement and disengagement practices.

Deck Cutting Height Adjustment

Deck cutting height is adjustable in 1/4" (6.4mm) increments. The holes in the height adjusting bar are spaced at 1/2" (12.7mm) intervals. By turning the height adjusting stop around, 1/4" (6.4mm) increments can be attained due to the 1/4" (6.4mm) plate that is part of the stop. Figure 3-1

EXAMPLE: When the height adjusting stop is placed in the 3" (76.2mm) hole, **with the 1/4" (6.4mm) plate facing to the front of the unit**, the cutting height is at 3" (76.2mm). When the height adjusting stop is placed in the 3" (76.2mm) hole, **with the 1/4" (6.4mm) plate on the operator's side of the hole**, the cutting height is at 3-1/4" (82.6mm).

The notch located at the rear of the height adjusting bar engages the stop handle when the deck lift pedal is fully depressed. This sets the deck in **transport mode**.

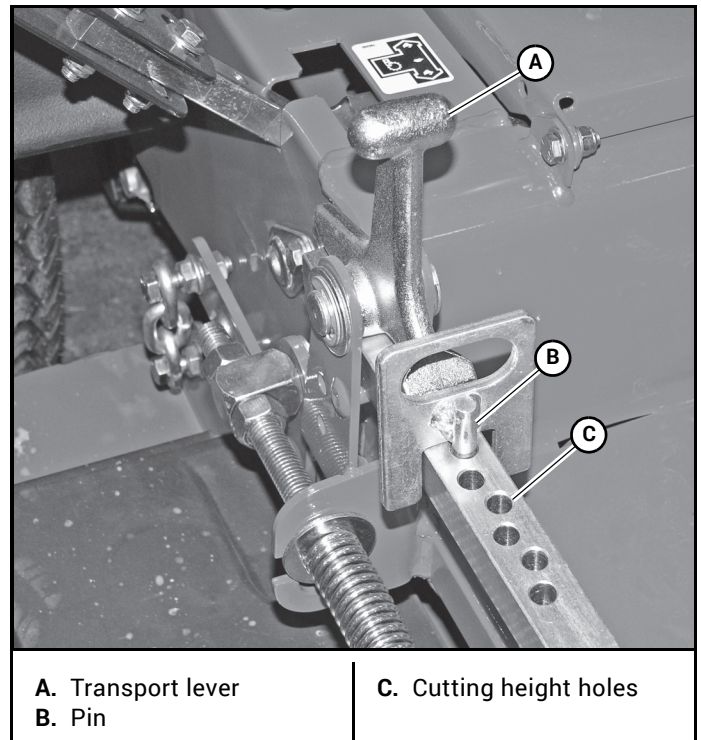

Figure 3-18

Air Flow Baffles

The decks are equipped with front adjustable air flow baffles. These baffles can be adjusted up or down, depending upon the mowing conditions, to provide the best quality of cut. Figure 3-19

NOTE: The air flow baffles are preset at the factory in the "B" setting.

The air flow baffles for the 48" and 54" decks come with two sets of holes per baffle. The baffle mounting hardware must be removed and the baffle moved up or down and the hardware re-installed in the correct set of holes and tightened. Figure 3-19

Setting	Conditions
A Bottom set of holes	Dry, sparse grass. Particularly useful when mowing at a height of cut of 3" (76.2mm) or higher. This setting provides the maximum vacuum and minimal blowout.
B 2 nd set of holes	Manicured lawns. Provides the best vacuum for the best cut when removing weekly/bi-weekly growth.
C 3 rd set of holes	Tall and stemmy grasses. The higher inner wall allows grasses to snap back up before contacting the blades to produce a cleaner cut.
D Top set of holes	Very tall and stemmy grasses. Allows the maximum height for grass to recoil before cutting. Well suited for utility cutting of overgrown grass.

The 60" and 72" decks come with three sets of mounting hardware for each air flow baffle. The middle set of hardware does not need to be removed when changing the baffle setting. This is a slot and the hardware only needs to be loosened enough to allow the baffle to slide. The other hardware on the ends of the baffles will need to be removed. After the baffles have been adjusted, re-install and tighten the outer hardware and tighten the middle hardware. Figure 3-20

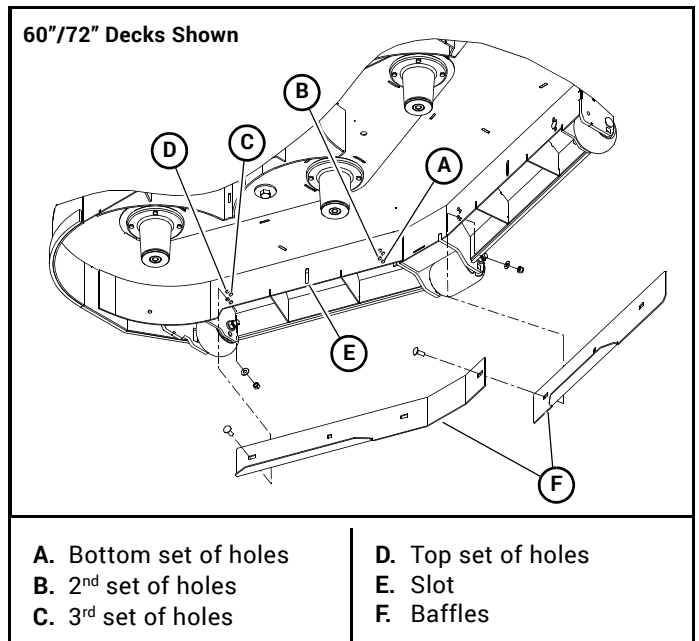

Figure 3-20

Anti-scalp Wheels

Anti-scalp wheels are standard on these mowers. These anti-scalp wheels are designed to minimize scalping when mowing on rough uneven terrain. Figure 3-21

Optional rear anti-scalp rollers are available.

These decks can be used with either one center anti-scalp roller, two side anti-scalp rollers or three rear anti-scalp rollers. Figure 3-21 & Figure 3-23

There are two height adjustment settings for the anti-scalp wheels/rollers. The upper hole positions the wheels/rollers 1" (25.4mm) below the cutting blades and the lower hole positions them 2" (50.8mm) below the cutting blades. Figure 3-21 & Figure 3-22

When the mowing height is set at 1" (25.4mm) to 3" (76.2mm) the anti-scalp wheels/rollers should be in the upper position.

When the mowing height is set at 3-1/4" (82.6mm) to 5" (127mm) the anti-scalp wheels/rollers should be in the lower position.

When adjusting the rear anti-scalp wheels, the wheel should be in the same axle mount hole as the front anti-scalp wheels.

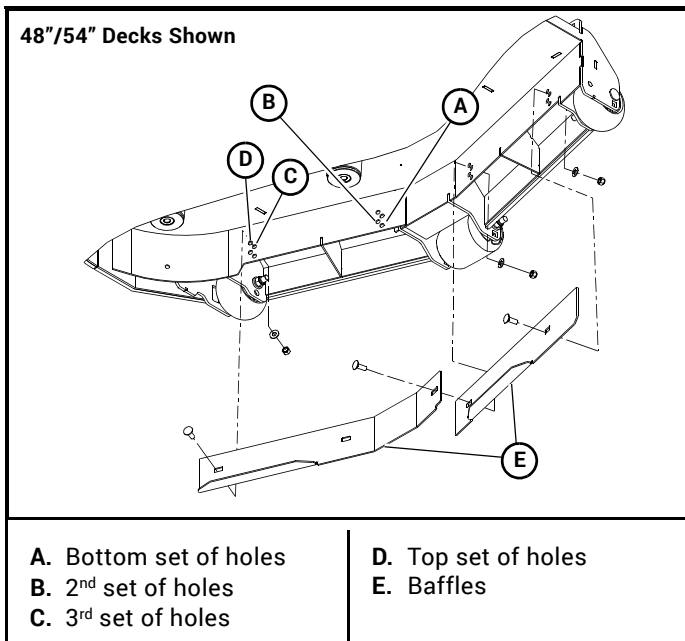

Figure 3-19

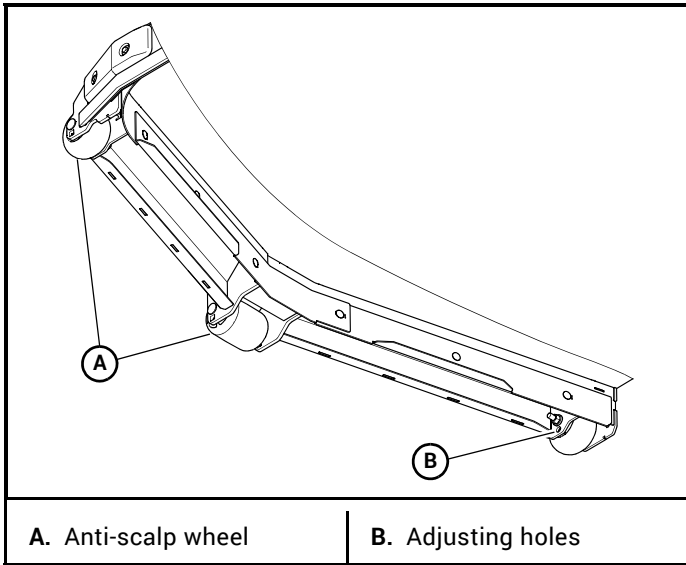

Figure 3-21

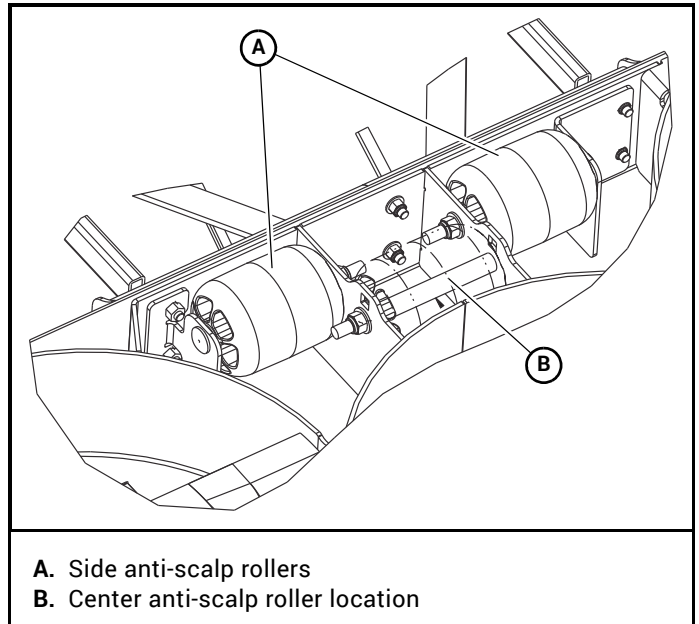

Figure 3-23

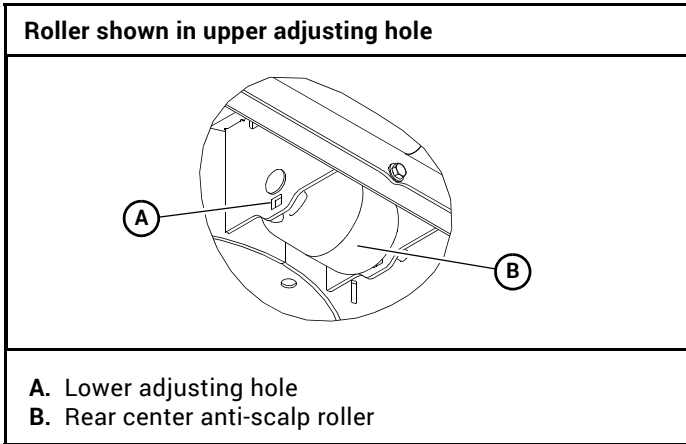

Figure 3-22

MAINTENANCE & ADJUSTMENTS

Safe Servicing Practices

Refer to the *Safety Precautions* section of this manual for more service safety information.

Service Introduction

Regular maintenance is the best prevention for costly downtime or expensive, premature repair. The following pages contain suggested maintenance information and schedules which the operator should follow on a routine basis. For more detailed information order the correct Parts Manual and General Service Manual for your unit. Refer to the *Product Literature* section of this manual for more information.

Remain alert for unusual noises, which could signal a problem. Visually inspect the machine for any abnormal wear or damage. A good time to detect potential problems is while performing scheduled maintenance service. Correcting the problem as quickly as possible is the best insurance.

Clear away heavy build-up of grease, oil and dirt, especially in the engine and hydraulic component areas; minute dust particles are abrasive to close-tolerance engine and hydraulic assemblies.

Inspect mower daily for grass clippings and wire or string tangles. The underside of the mower deck will collect a build-up of grass clippings and dirt, especially when grass is wet or has high moisture content. This build-up will harden, restricting blade and air movement which will probably result in a poorer quality of cutting. Therefore it should be removed routinely. To do this it will be necessary to raise and block the deck using jack stands or blocks in the full up position. Scrape the build-up off from underneath.

IMPORTANT: Seat arm rests – Place the steering control levers in the park brake position and pivot the arm rests upward before lifting the seat platform to prevent arm rest damage.

Some repairs require the assistance of a trained service mechanic and should not be attempted by unskilled personnel. Consult your Hustler® service center when assistance is needed.

Torque Values

WARNING Particular attention must be given to tightening the drive wheel lug nuts and blade spindle bolts. Failure to correctly torque these items may result in the loss of a wheel or blade, which can cause serious damage or personal injury.

Torque values are given below:

	ft-lbs	N•m
Wheel (lug) nuts	70	95
Blade spindle bolt top	70	95
Blade spindle bolt bottom	118	160
Wheel motor nut	230	312

Lug nuts only - It is recommended that these be checked after the first 2 hours of operation, initially, every 50 hours and following removal for repair or replacement.

For all other torques refer to the mower's *General Service Manual* for standard torque chart. See *Product Literature* section for ordering information.

For engine torque values, refer to the engine owner's manual.

Tires

It is important for level mowing that the tires have the same amount of air pressure. The recommended pressures are:

Drive wheels	8–12 psi (55–83 KPa)
Front wheels	8–12 psi (55–83 KPa)

If you wish to use non-pneumatic tires on your Hustler® mower, the tire must be a Hustler® approved tire. Warranty claims will be denied on any mower equipped with unapproved non-pneumatic tires.

Flex Forks® Break-In

Flex Forks® may raise the front of the mower approximately 1" when first installed. It is not necessary to re-level the deck at this time. Drive the mower for approximately 20 minutes, stop the mower and check to see if the deck is level. If adjustment is required, refer to the mower's *General Service Manual* for deck leveling procedures.

DANGER Never attempt to make any adjustments to the mower deck while the engine is running or with the deck drive clutch engaged. Mower blades cannot be seen and are located very close to the deck housing. Fingers and toes can be cut off instantly.

Lubrication

Use SAE multi-purpose grease.

Electrical System

IMPORTANT: Refer to the *Safety* section of this manual for detailed battery servicing safety information.

The electrical system is a 12 volt, negative ground. The recommended battery size is:

Garden tractor BCI group 45 with a 480 or better cranking AMP rating.

A maintenance-free battery is recommended. Otherwise, follow battery manufacturer's maintenance, safety, storing and charging specifications.

Master In-line Fuse

These mowers have a 50 amp in-line fuse in the electrical system. This is the main fuse to protect the complete electrical system. It is located at the rear of the machine close to the battery. Figure 4-1

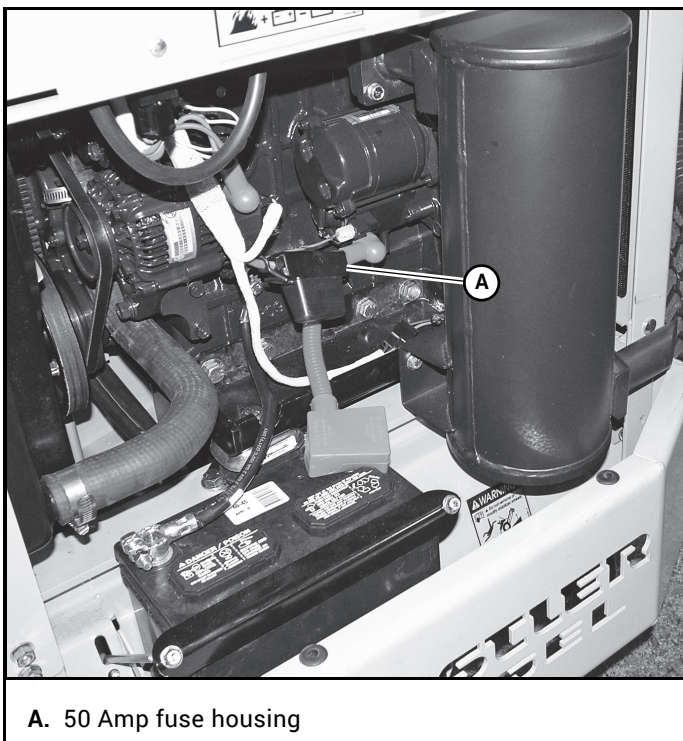

A. 50 Amp fuse housing

Figure 4-1

Hydraulic System

IMPORTANT: Never use hydraulic or automatic transmission fluid in this system; use only motor oil as specified. Remember, dirt is the primary enemy of any hydraulic system.



Hydraulic fluid escaping under pressure may have sufficient force to penetrate skin and cause serious injury. Foreign fluid injected into the skin must be surgically removed within a few hours by a doctor, familiar with this form of injury, or gangrene may result.

Before applying pressure to hydraulic system, make sure all connections are tight and all hoses and lines are in good condition. To find a leak under pressure, use a piece of cardboard or wood – **never** use your hands. Relieve all pressure in the system before disconnecting or working on hydraulic lines. To relieve pressure, lower all attachments and shut off engine.

Check oil level in hydraulic system after every 50 hours of operation or weekly, whichever occurs first. Check more often if system appears to be leaking or otherwise malfunctioning.

Fluid level should be 1" (25.4mm) from top of reservoir. Use only **SAE 20W50 motor oil, 15W50 synthetic oil, or 20W50 synthetic oil**. Hustler® Full Synthetic 20W50 Hydrostatic Transmission Oil is recommended. Figure 4-2

NOTE: The reservoir will require approximately 7 U.S. quarts (6.6 liter) of **SAE 20W50 motor oil, 15W50 synthetic oil, or 20W50 synthetic oil** when replacing the oil after an oil and filter change. **Do not** overfill the reservoir.

Initial system oil and filter change **must** be after the first 50 hours of mower operation. Then replace the filter and oil in the reservoir **annually or every 500 hours, whichever comes first**. Figure 4-3

IMPORTANT: It is necessary to drain the system oil from the hydraulic reservoir, using the reservoir drain plug, before removing the hydraulic filter. Replace the drain plug before adding system oil.

The hydraulic system filter is located inside the hydraulic reservoir on the rear underneath side of the tank. Use a 5/8" socket to change the filter, threads are right handed. Use a **Hustler® Turf Equipment approved filter element only**.

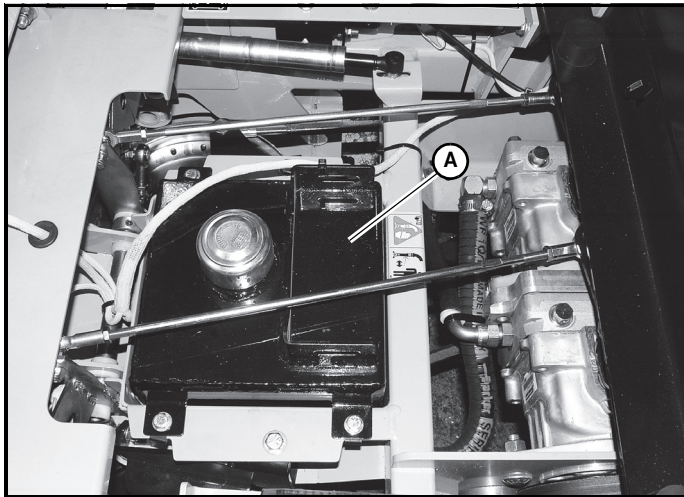

A. Hydraulic reservoir

Figure 4-2

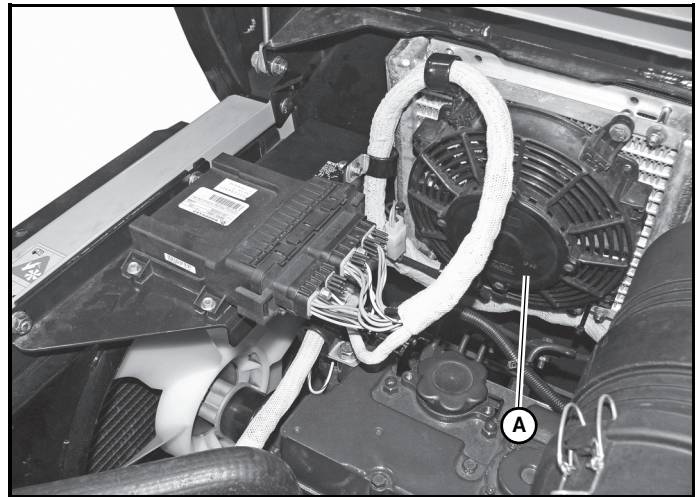

A. Heat exchanger

Figure 4-4

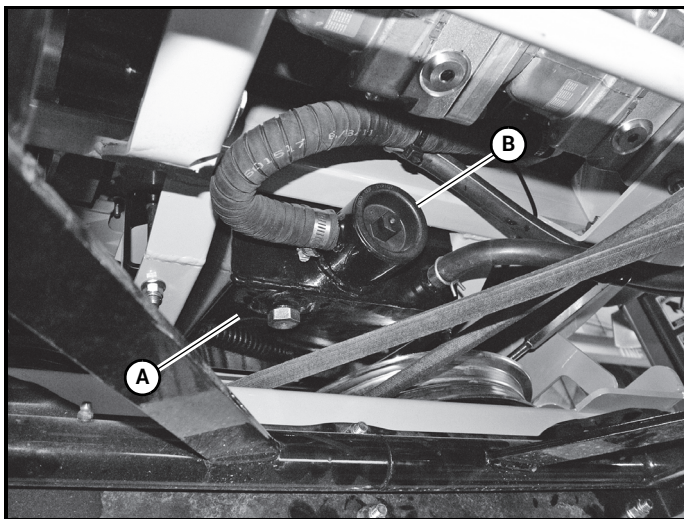

A. Hydraulic reservoir

B. Hydraulic filter

Figure 4-3

Hydraulic Oil Heat Exchanger

These mowers are equipped with a hydraulic oil heat exchanger. The heat exchanger coils must be kept clean to insure that the hydraulic oil is operating within the correct temperature range.

Check and clean the heat exchanger daily and more often in dirty, dusty conditions. Figure 4-4

Fuel System

Refer to the **Safety** section of this manual for fuel handling safety information.

IMPORTANT: Refer to the engine owner's manual for additional emissions control information.

The fuel tanks are located in the mower's fenders. These engines require number 2 diesel fuel only.

Park the mower on level ground before filling the fuel tank.

Clean the area around the fuel cap before removing the cap. Remove the fuel cap slowly.

Fuel Shut-off Valve

These mowers are equipped with a **fuel shutoff valve** located to the right rear of the seat. Rotate the valve to the middle position to allow fuel to flow from the right fuel tank to the fuel pump. The right position prevents fuel flow to the fuel pump. The left position allows fuel to flow from the left fuel tank to the fuel pump. Close this valve to prevent fuel flow to the engine when servicing the fuel system or when transporting the unit on a trailer or truck. Figure 4-5

Priming the Fuel System

If the diesel fuel system runs dry, use the following procedure when re-starting the engine:

1. Refill the fuel tanks.
2. Make sure the fuel shutoff valve is turned to the full fuel tank.
3. Take the priming bulb and compress it until it becomes firm. Figure 4-6
4. Try and start the engine. If it will not start after 15 seconds of cranking, repeat Step 3.

If after trying several times, the engine still will not start, contact your Hustler® Dealer.

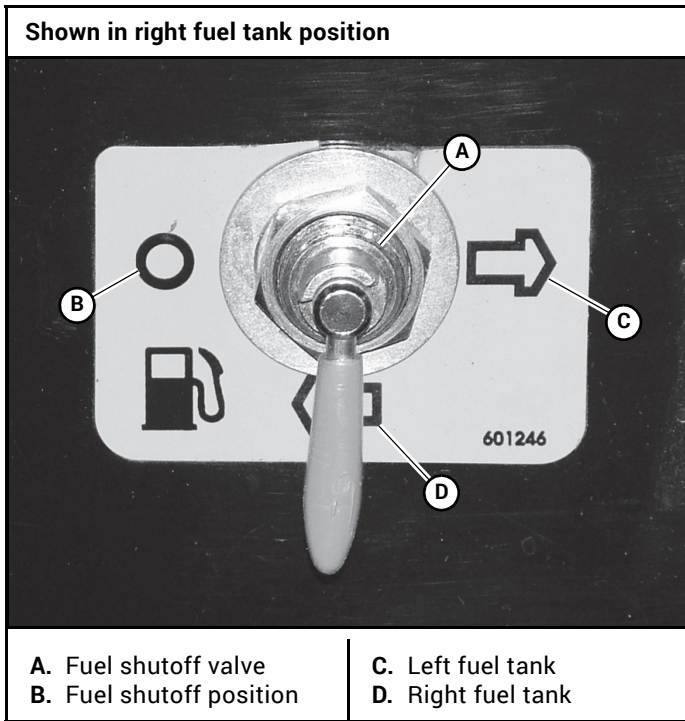

Figure 4-5

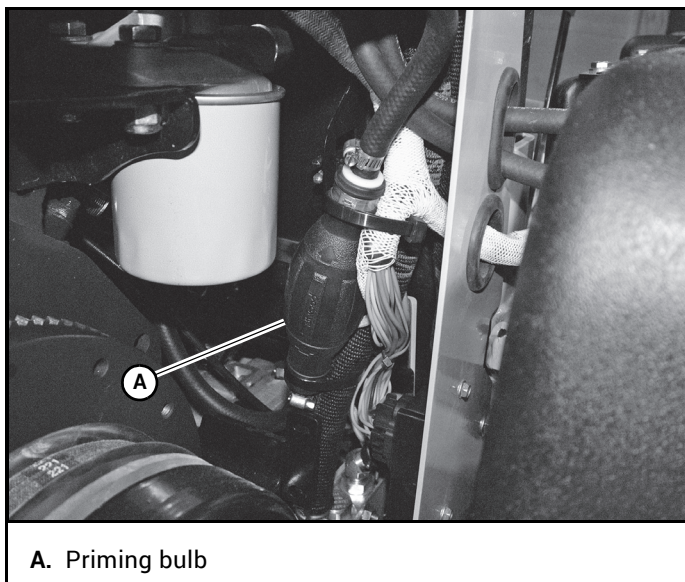

Figure 4-6

Engine Controller (Tier 4 Engines Only)

The engine controller is used on all Tier 4 engines. It monitors and controls the engine's fuel emissions. When a problem is detected, a code is sent to the Engine Warning Light located on the control panel.

Refer to the Hustler® Z Diesel General Service Manual (P/N 115164) for code identification and troubleshooting.

Engine Oil and Filter

Check engine oil daily and after every 4 hours of operation. Machine must be setting level when checking oil. Refer to engine manual and maintenance schedule for oil recommendation and capacities. Hustler® Motor Oil is recommended.

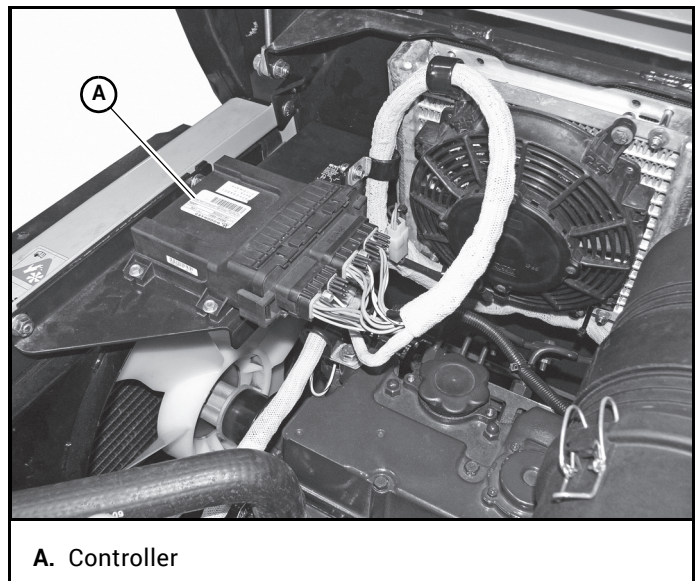

Figure 4-7

WARNING ⚠

If the engine has been running and is up to operating temperature, allow the engine to cool before changing the oil. Engine and engine oil will be very hot, so be very careful when changing oil and wear the appropriate protective gear to avoid being burned or exposed to engine oil.

Change the engine oil and filter after the first 5 hours of operation and per the engine manufacturer's recommendations after that. If mower is being operated in extremely dirty conditions, then it is recommended oil be changed more frequently. **IMPORTANT:** When removing the oil filter take precautions to minimize oil spillage on the exhaust system.

The oil filter and oil drain plug are located on the underneath side of the engine. Figure 4-8

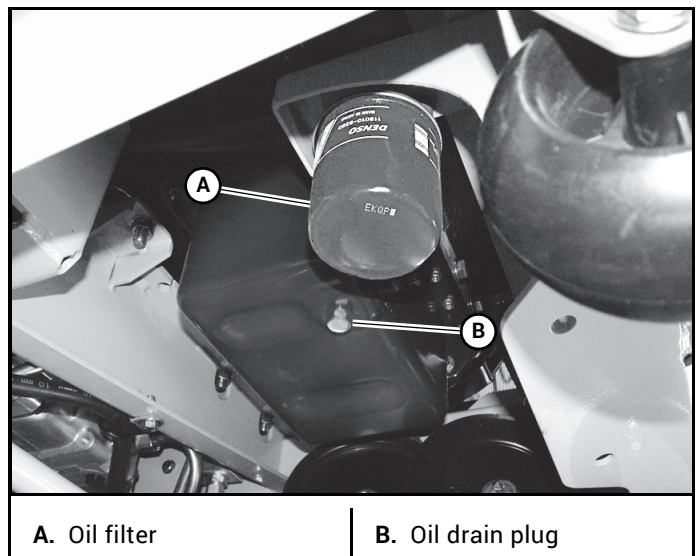

Figure 4-8

Engine Air Filter

Perform engine air filter maintenance per the *Maintenance Schedule* shown elsewhere in this manual.

A specially designed dry filter is standard equipment on these mowers and supplies clean combustion air to the engine. Figure 4-9

These mowers are equipped with a safety filter. The filter element slides over the safety filter. Figure 4-10

The safety filter does not require servicing unless it becomes contaminated with dirt or moisture.

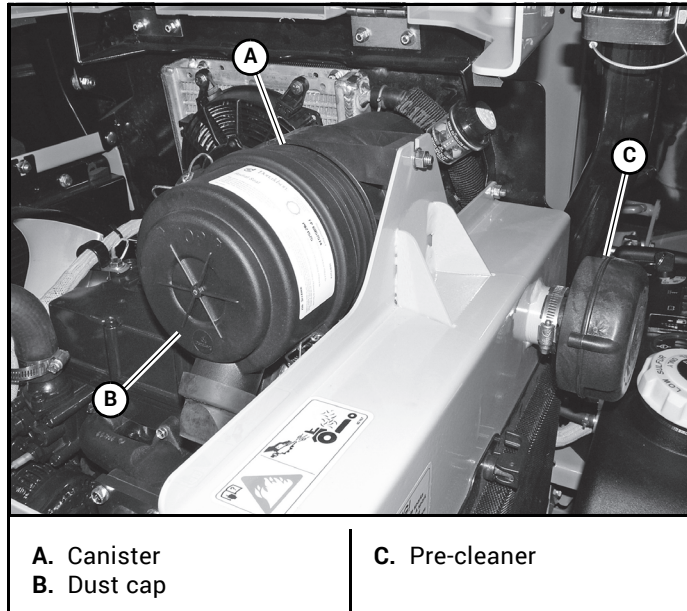

Figure 4-9

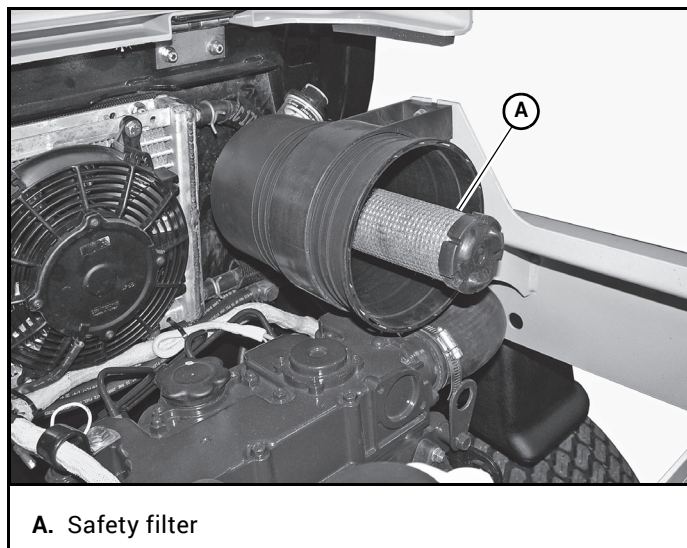

Figure 4-10

Recommended service procedure

1. Release clamps and remove element. Clean the canister with a damp cloth.

2. Before installing a new element, inspect it by placing a bright light inside and rotating the element slowly, looking for any holes or tears in the paper. Also check gaskets for cuts or tears. Do not attempt to use a damaged element which will allow abrasive particles to enter the engine.
3. Reinstall the dust cap. Make sure it seals all the way around the air cleaner body, then tighten the clamps.
4. Check all fittings and clamps periodically for tightness and inspect hoses for holes or cracks.
5. Periodically check the intake hose for signs of ingested dust. Locate and repair the source of ingested dirt.
6. Never operate the machine without an air filter installed.

Overservicing

Overservicing occurs when an air filter element is removed for cleaning or replacement before it is necessary. Each time the filter is removed a small amount of dirt and dust could fall in the intake system. This accumulated dirt can cause a dusted engine. It only takes a few grams of ingested dirt over the normal service life of an engine to cause a dusted engine.

Do not clean the element, replace with a new element only. Cleaning used air filter elements, through improper cleaning procedures, can get dust on the inside of the filter causing dirt ingestion and engine failure.

It is important to note that whenever an air filter element is cleaned by **any method**, the person or company performing the cleaning assumes responsibility for the integrity of the filter from then on. **The warranty for air filters expires upon cleaning or servicing in any manner because the condition of the filter after servicing is completely out of the filter manufacturer's control. Therefore, on a dust ingested engine failure, there will be no warranty consideration if the air filter element has been cleaned or serviced in any manner.**

A partially dirty air filter element works better than a new element. A dirty filter element is not bad for the engine unless it restricts the air flow too much and engine performance is affected. The media in the filter must be porous to allow air to pass through it. When dirty air passes through the filter, the dirt plugs some of the holes in the media and acts as part of the filter media. When the next round of dirt enters, the first dirt layer helps filter out even smaller particles making the filter more efficient at stopping dirt from entering the engine. This is referred to as barrier filtration.

At some point the filter media will become too clogged to allow air to pass.

The mowing conditions will determine the frequency of air filter element changing.

Air Restriction Indicator

These units have an air restriction indicator installed in the air cleaner. Figure 4-11

Replace the element whenever the restriction indicator reaches the change filter red line. Check the indicator daily and replace element as needed or annually whichever occurs first.

Reset the indicator by pushing in on the yellow button after each element change. Figure 4-11

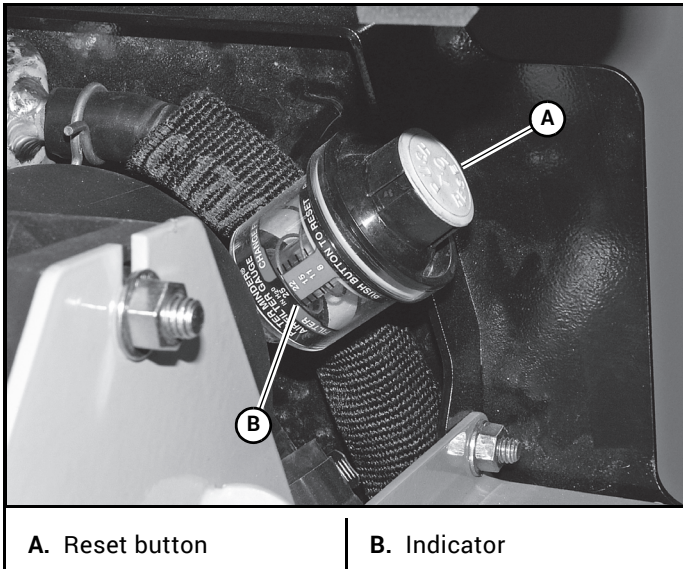

Figure 4-11

Cooling System



Never remove radiator cap or overflow reservoir cap when engine is hot. Pressurized hot steam and water may be released, causing serious burns or possible blindness. Figure 4-12

Engine cooling is accomplished with circulated water and Ethylene Glycol mixture. The radiator is equipped with a pressure cap and recovery tank. A 50-50 mixture is recommended for all season operation. This mixture provides freeze protection to -32 degrees F (-35 degrees C). Should temperatures fall below this level, additional Ethylene Glycol must be added to the mixture.

Visually inspect the system daily prior to operating the mower. Check coolant level in the recovery tank located to the left rear of the engine (Figure 4-12). When the engine is cold the coolant should be up to the cold mark on the recovery tank. When the engine is hot the coolant should be up to the hot mark on the recovery tank. When adding coolant, pre-mix the solution before adding it to the recovery tank. It is not necessary to remove radiator cap for adding small amounts of coolant to the system.

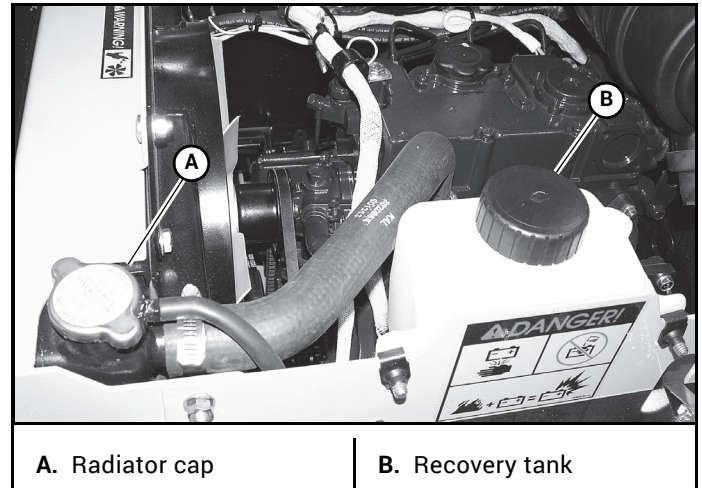

Figure 4-12

General Engine Maintenance

Detailed instructions and recommendations for break-in and regular maintenance are specified in the *Engine Owner's Manual*. Please refer to this manual for engine servicing, lubricating oil levels with quality and viscosity recommendations, bolt torques, etc. The engine warranty is backed by the engine manufacturer. Special attention should be paid to applicable data which will not be duplicated here.

Belts

Inspect belts frequently for wear and serviceability. Replace a belt that shows signs of:

- severe cuts
- tears
- separation
- weather checking
- cracking
- burns caused by slipping.

Slight raveling of belt covering does not indicate failure, trim ravelings with a sharp knife.



If the pump belt fails, loss of control will occur especially when operating on a slope. **If you lose steering control while operating the machine, place the steering control levers in the park brake position immediately. Inspect the machine and involve your Hustler® Dealer to resolve the problem before continuing to operate.**

Inspect the belt pulley grooves and flanges for wear. A new belt, or one in good condition, should never run against the bottom of the groove. Replace the pulley when this is the case, otherwise the belt will lose power and slip excessively.

Never pry a belt to get it on a pulley as this will cut or damage the fibers of the belt covering.

Keep oil and grease away from belts, and never use belt dressings. Any of these will destroy the belt composition in a very short time.

Mower Blade

Mower Blade Maintenance

IMPORTANT: Refer to the *Safety* section of this manual for blade handling safety information.

Refer to the *Mower Blade Replacement* section for blade removal and installation.

WARNING Mower blades are sharp and can cut. Wrap the blade(s) or wear gloves and use extra caution when servicing them.

Check the mower blades daily, they are the key to power efficiency and well groomed turf. Keep the blades sharp. A dull blade will tear rather than cut the grass, leaving a brown ragged top on the grass within a few hours. A dull blade also requires more power from the engine.

Replace any blade which is bent, cracked or broken.

WARNING **Always check for blade damage:**

- if mower strikes a rock, branch or other foreign object during mowing!
- or if an abnormal vibration occurs while operating.

Make all necessary repairs before resuming operation.

Sharpen the blades following the pattern shown. Touch-up sharpening can be done with a file. Figure 4-13

After grinding the blades, check for balance. Blade balancing can be done by placing the blade on an inverted line punch or 5/8" bolt. A commercial balancing tool is also available through most hardware supply stores.

The blade should not lean or tilt. When spinning the blade slowly it should not wobble. Balance the blade before reinstalling.

Lay the blade on a flat surface and check for distortion. Replace any distorted blade. Figure 4-14 & Figure 4-15

Do not sharpen to original pattern (below). It is easier to get a straight cutting edge following the re-sharpening pattern shown above.

A. Re-sharpening pattern
B. Original edge

Figure 4-13

Comparison of Warped and Straight Blades

A. Warped blade – replace
B. Straight blade
C. Cutting plane

Figure 4-14

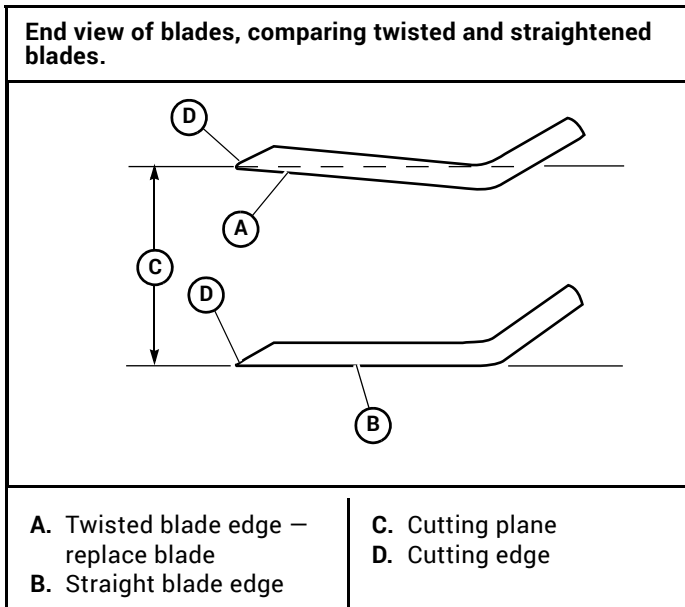

Figure 4-15

Mower Blade Replacement

IMPORTANT: Refer to the *Safety* section of this manual for blade handling safety information.

WARNING Mower blades are sharp and can cut. Wrap the blade(s) or wear gloves and use extra caution when servicing them.

A 15/16" wrench is required to remove the 5/8" cap screw holding the blade to the spindle shaft. **NOTE:** A blade holding tool (P/N 381442) is available from Hustler® Turf Equipment. It is designed to prevent the blades from rotating when they are being removed or installed on the spindle. Contact your Hustler® Dealer for more information.

Do not re-use spindle bolts which have stripped, worn or undercut threads. Torque bolts on spindles to 118 ft-lbs (160.0 N•m) when reinstalling blades.

WARNING Failure to correctly torque the bolt may result in the loss of the blade which can cause serious injury.

Properly compressed cup washers maintain the correct compression load on the blades. Replace the cup washers if they are cracked or flattened.

IMPORTANT: The blade sail (curved part) must be pointing upward toward the inside of the deck to ensure proper cutting.

When mounting blades, rotate them after installation to ensure blade tips do not touch each other or sides of the mower.

Seat Adjustment

IMPORTANT: Any maintenance operation that requires the removal of safety covers **must** be performed by a trained service technician.

There are two seat options available for these mowers. The following are the adjustments for each of these seats.

Seat (Option 1)

This seat can be adjusted five different ways to obtain the most comfortable position:

1. Back angle (Figure 4-16)
2. Forward and rearward travel (Figure 4-16)
3. Weight (Figure 4-16)
4. Isolator (Figure 4-16)
5. Armrest (Figure 4-17)

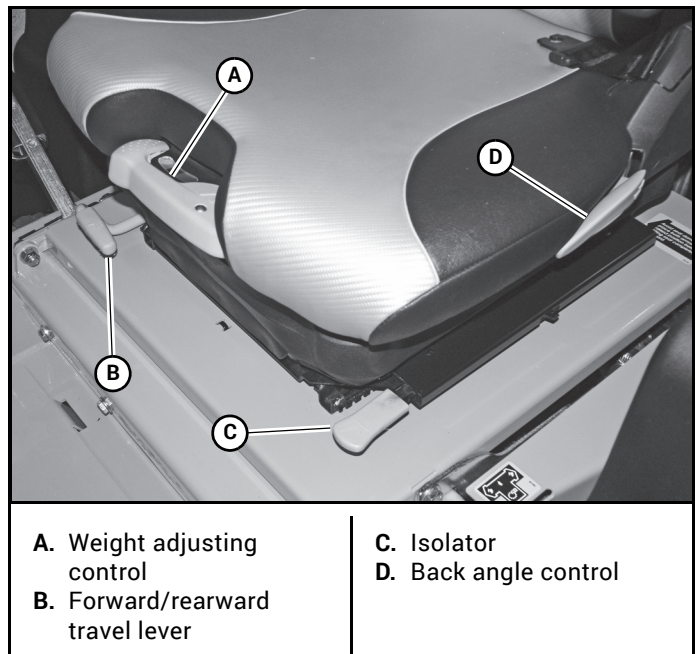

Figure 4-16



A. Armrest control

Figure 4-17

Seat (Option 2)

This seat can be adjusted five different ways to obtain the most comfortable position:

1. Back angle (Figure 4-19)
2. Forward and rearward travel (Figure 4-18)
3. Weight (Figure 4-18)
4. Lumbar (Figure 4-20)
5. Armrest (Figure 4-21)

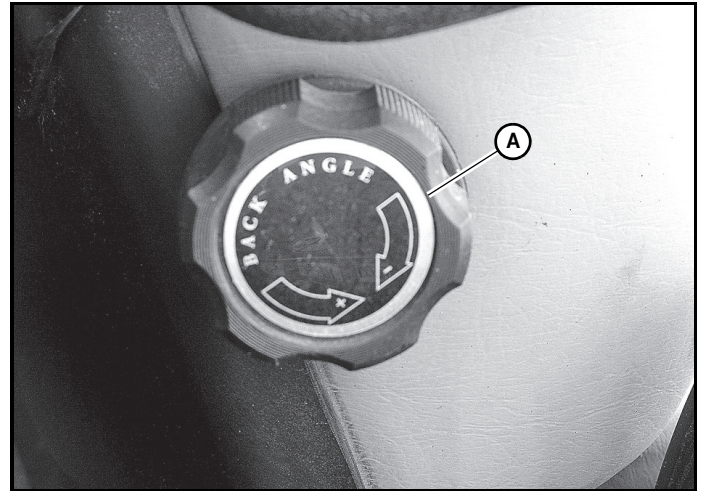

A. Back angle control

Figure 4-19

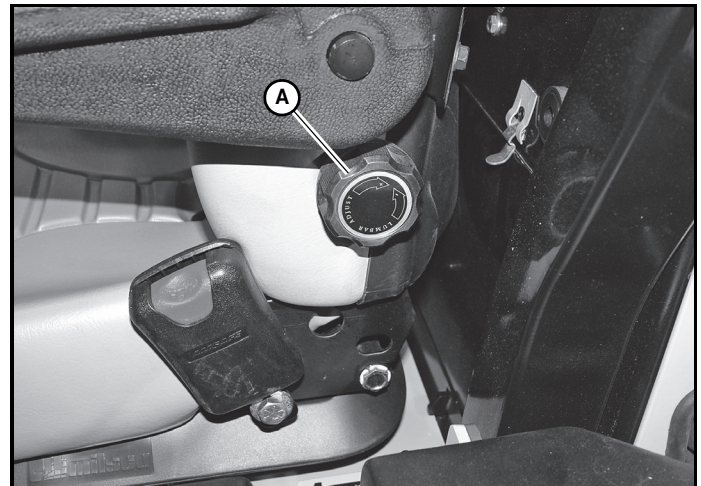

A. Lumbar control

Figure 4-20

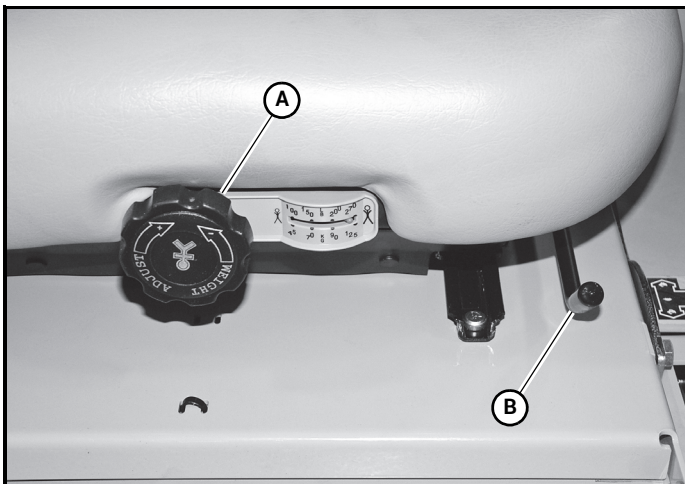

A. Weight adjusting control

B. Forward/rearward travel lever

Figure 4-18



A. Armrest control

Figure 4-21

Steering Control Lever Adjustment

The steering control levers can be adjusted for operator comfort. By loosening the cap screws that attach the upper control lever to the lower lever (Figure 4-22), the upper control lever can be pivoted to fit the operator's personal preference.

The steering control levers can also be adjusted up and down. Remove the cap screws and slide the upper control lever up or down and align the holes in it with the holes in the lower lever. Re-install the cap screws and tighten.

The steering control levers should be adjusted so that they align with each other when in the neutral position.

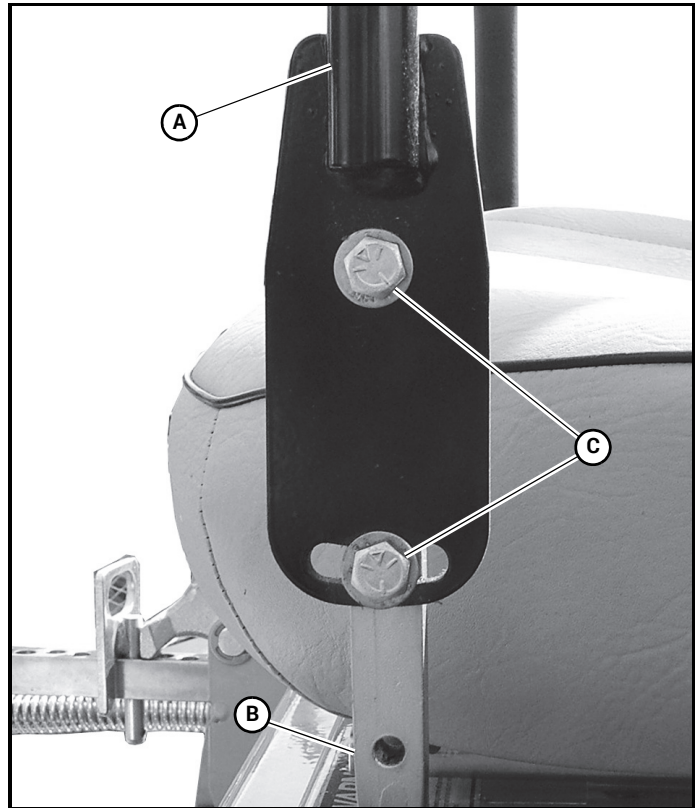

A. Upper control lever
B. Lower control lever

C. Cap screws

Figure 4-22

Maintenance Schedule			
Figure 4-23, Figure 4-24, Figure 4-25, Figure 4-26, Figure 4-27, Figure 4-28, & Figure 4-29			
SERVICE AT INTERVALS INDICATED	WEEKLY OR 50 HOURS	MONTHLY OR 100 HOURS	* ANNUALLY OR 500 HOURS
Verify safety start interlock system	Prior to each use		
Visually inspect unit for loose hardware and/or damaged parts	Prior to each use		
Visually inspect tires	Prior to each use		
Check oil level, engine (1)(4)	Prior to each use or every 4 hours		
Clean oil heat exchanger (8)	Prior to each use or every 4 hours		
Check radiator screen (8)	Prior to each use or every 4 hours		
Clean air intake screen (8)	Prior to each use or every 4 hours		
Check fuel level	Prior to each use		
Blades - sharpen & securely fastened	Prior to each use		
Discharge chute - securely in place & in lowest position	Prior to each use		
Rear discharge deck flaps and/or power unit deflector securely in place	Prior to each use		
Clean engine and pump compartment (12)	Daily		
Check air cleaner service indicator (8)	Daily		
Replace engine air cleaner element (5)(10)	As needed		
Caster fork tapered bearings (11)	Regular maintenance not required		
Change engine oil and filter (1) (4)	X		
Clean cylinder and head fins (10)	X		
Check battery connections (12)	X		
Check tire pressure with a gauge	X		
Check hydraulic oil level (12)	X		
Clean engine exterior (10)	X		
Grease deck pusher arms (8)		X	
Grease pump idler (8)		X	
Grease deck height pivots (8)		X	
Grease front wheel bearings (8)		X	
Check pump and deck belt tension and condition (6) (12)		X	
Check fuel system (7) (12)		X	
Check hydraulic lines (12)		X	
Check fuel valve (7)		X	
Check fuel tank grommets (7)		X	
Tighten lug nuts on wheels (2)		X	
Change fuel filter (7)			X
Clean or replace hydraulic fill cap (12)			X
Change hydraulic filter & oil (3) (12)			X
Grease deck spindle housings			X
Injection nozzle check			X
Check ROPS mounting hardware (9)			X
Cooling system circuit cleaning (8)			X

NOTES:

1. Initial engine oil change is after 5 hours of operation. Thereafter, change oil after every 40 hours operation. Change more often under dusty or dirty conditions and during hot weather periods. Hustler® Motor Oil is recommended.
2. Torque initially and after first 2 hours of operation.
3. Perform initial hydraulic oil and filter change after **50 hours** (one week) of operation. Thereafter, **change oil and filter annually or every 500 hours** whichever comes first. Hustler® Full Synthetic 20W50 Hydrostatic Transmission Oil is recommended.
4. Change engine oil filter per the engine manufacturer's recommendations. Refer to Engine Owner's Manual for recommendations and other maintenance items.

5. Service more often under dusty or dirty conditions. Use caution when servicing to prevent dust contamination in the engine. **Do not** clean filter element. Replace with a new one.
6. **Pump drive belt only - Inspect belt every 100 hours** and replace if worn or cracking is noticed. Check spring tension adjustment. Otherwise, **replace belt every 400 hours or 2 years** whichever comes first. Check and adjust spring tension after 50 hours of use as outlined in the *Hydraulic Pump Belt Adjustment* section of the General Service Manual (115164).
7. Check fuel system for any cracks or leaks including, but not limited to, fuel line hoses, fuel valve, vent line hoses, vent valve, vapor valve, carbon canister, and grommets. Replace as needed.
8. More often under dusty or dirty conditions and during hot weather.
9. Inspect ROPS after the first 20 hours of operation and then after every 500 hours of operation or yearly whichever comes first.
10. Refer to engine owner's manual for engine service information.
11. Any maintenance operation that requires the removal of safety covers **must** be performed by a trained service technician.

* After completing maintenance cycle (500 hours), repeat cycle.

Maintenance Locator Chart

Figure 4-23

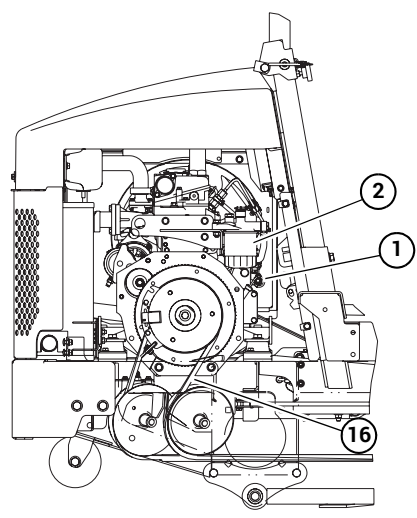
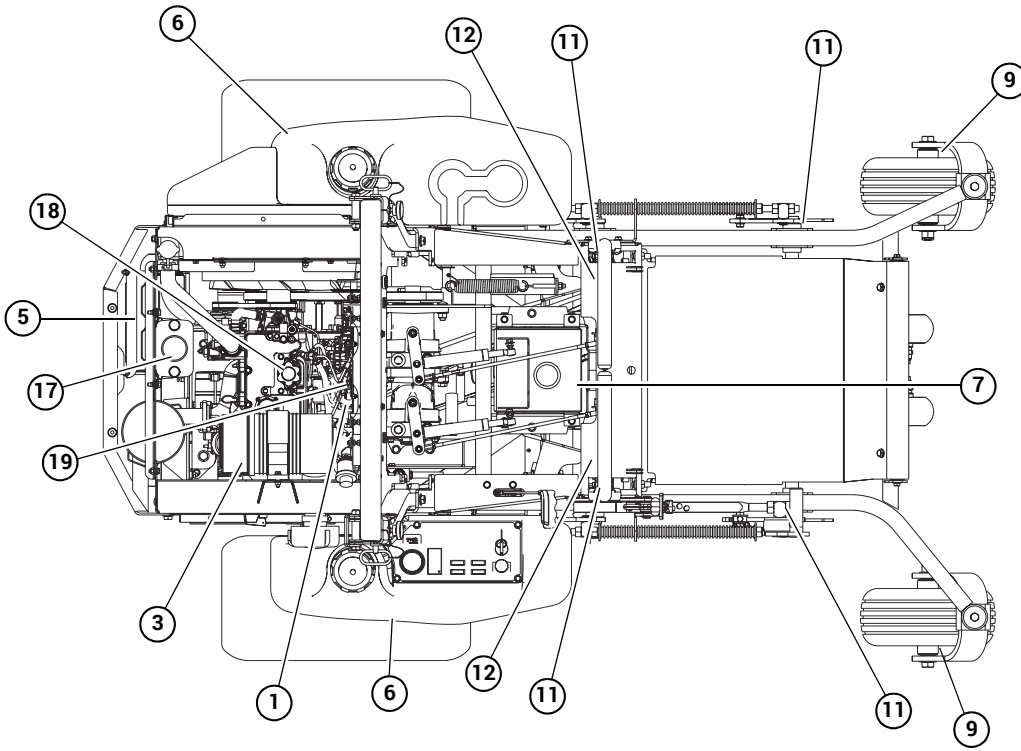

Figure 4-24

1. Engine Oil Dipstick
2. Fuel Filter
3. Engine Air Cleaner
4. Engine Oil Drain Plug
5. Battery
6. Fuel Tanks
7. Hydraulic Oil Reservoir
8. Hydraulic Oil Filter
9. Gauge Wheel Bearing Zerk (2)
10. Engine Oil Filter
11. Deck Height Pivot Zerks (4)
12. Park Brake Switch
13. Drive Tire
14. Pump Idler Zerk (1)
15. Pump Belt
16. Deck Drive Belt
17. Engine Coolant Fill
18. Engine Oil Fill
19. Hydraulic Oil Heat Exchanger

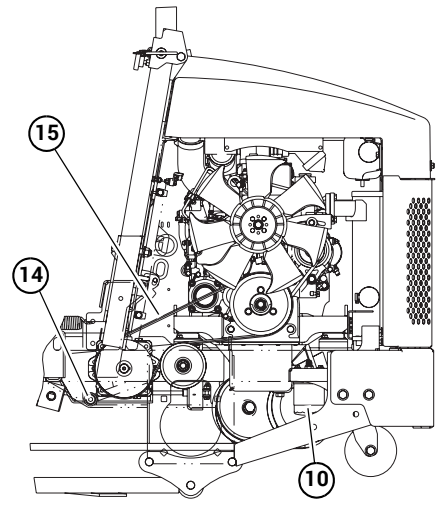

Figure 4-25

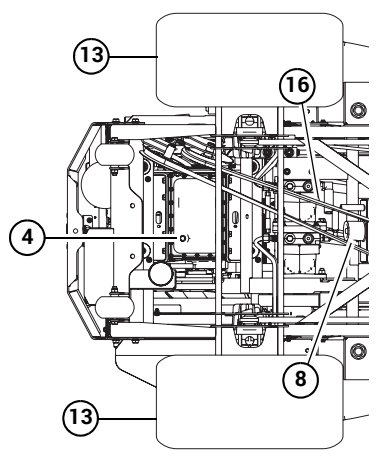
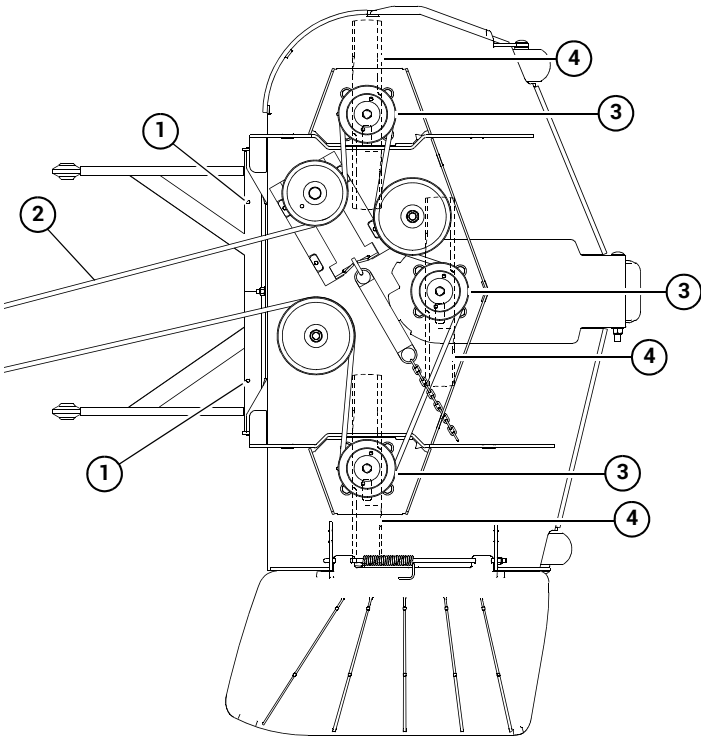

Figure 4-26

Side Discharge Deck



- 1. Deck Pusher Arm Zerks (2)
- 2. Deck Belt (1 or 2)
- 3. Spindle Housing Zerks (3)
- 4. Blades (3)

Figure 4-27

Rear Discharge Deck

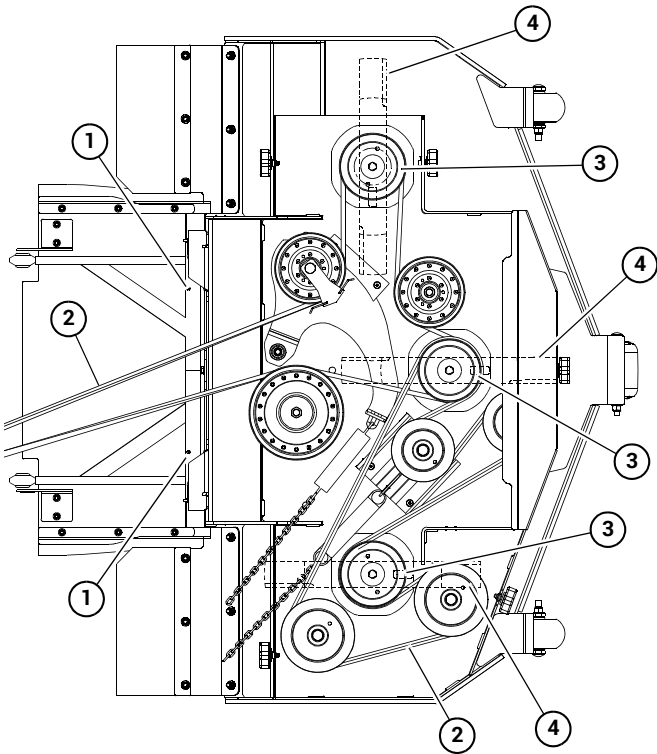

Figure 4-28

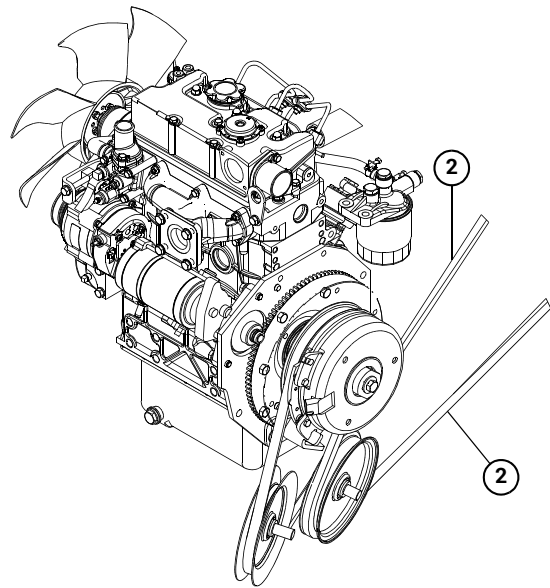

Figure 4-29

Maintenance Record

Perform the initial hydraulic system oil and filter change after the first 50 hours of use.

Date:	Maintenance/Service Performed:
Dealer:	
Hour Meter Reading:	
Date:	Maintenance/Service Performed:
Dealer:	
Hour Meter Reading:	
Date:	Maintenance/Service Performed:
Dealer:	
Hour Meter Reading:	
Date:	Maintenance/Service Performed:
Dealer:	
Hour Meter Reading:	
Date:	Maintenance/Service Performed:
Dealer:	
Hour Meter Reading:	

Date:	Maintenance/Service Performed:
Dealer:	
Hour Meter Reading:	
Date:	Maintenance/Service Performed:
Dealer:	
Hour Meter Reading:	
Date:	Maintenance/Service Performed:
Dealer:	
Hour Meter Reading:	
Date:	Maintenance/Service Performed:
Dealer:	
Hour Meter Reading:	
Date:	Maintenance/Service Performed:
Dealer:	
Hour Meter Reading:	

TROUBLESHOOTING

The majority of operating problems that occur with a system can be traced to improper adjustments or delayed service. A consistently applied preventative maintenance program, as outlined in the *Maintenance* section of this manual, will prevent many problems. The following chart is designed to help you locate a problem by suggesting probable causes and the recommended solutions.

SYMPTOMS	PROBABLE CAUSES	SUGGESTED REMEDIES	
Starting motor does not crank	Steering control levers not in park brake position or switch not adjusted	Place steering control levers in park brake position or re-adjust switch	
	Deck clutch switch engaged	Disengage clutch switch	
	Weak or dead battery	Recharge or replace	
	Electrical connections are corroded or loose	Check the electrical connections	
	For additional causes	See engine manual	
The engine will not start, starts hard or fails to keep running	No fuel or line plugged	Fill tank or replace line (See <i>Fuel System</i> section for more details)	
	Fuel valve is turned off	Open the fuel valve	
	There is incorrect fuel in the fuel system	Drain the tank and replace the fuel with the proper type	
	There is dirt in the fuel filter	Replace the fuel filter	
	Dirt, water or stale fuel in the fuel system	Contact your dealer	
	Numerous	See engine manual	
Engine: Runs with continuous misfiring or engine runs unevenly or erratically	Numerous	See engine manual	
Loss of power or system will not operate in either direction	Restrictions in air cleaner	Service air cleaner	
	Hydraulic line blockage	See your dealer	
	Internal interference or leakage in wheel motor	See your dealer	
	Insufficient hydraulic oil supply	Check level in reservoir	
		Have dealer check hydraulic pump	
	Poor compression	See your dealer	
	Steering linkage needs adjustment	Adjust linkage	
	Tow valve open	Close tow valve	
	The traction drive belt is worn, loose or broken	Install a new traction drive belt	
	Air in system	Check filter and fittings	
For additional causes	See engine manual		
Liquid cooled or Diesel engines overheating: Temperature light glows Frequent refilling of radiator required Coolant appears rusty Audible alarm	Leaks in system	Replace/tighten hoses and connections	
	Coolant level low	Add coolant	
	Radiator screen clogged	Clean screen	
	Thermostat sticking or inoperative	See engine manual	
	Heat light malfunction	Contact your dealer	

SYMPTOMS	PROBABLE CAUSES	SUGGESTED REMEDIES
Low engine oil pressure	Low oil level	Add oil
	Oil diluted or too light	Change oil and check for source of contamination
	Failed oil pump	Contact your dealer
High oil consumption	Numerous	Contact your dealer
Mower jerky when starting or operates in one direction only	Steering control linkage needs adjustment	Adjust linkage
	Pump or wheel motors faulty	Contact your dealer
	Tow valves not closed completely	Close tow valves
Hydraulic system operates hot (oil in reservoir smells rancid)	Low hydraulic oil level	Fill reservoir
	Hydraulic pump faulty	Contact your dealer
	Hydraulic oil heat exchanger clogged	Clean oil heat exchanger core
Mower creeps when steering control levers are in neutral	Steering linkage needs adjustment	Adjust linkage
Mower circles or veers in one direction	Steering linkage needs adjustment	Adjust linkage
	Wheel motors faulty	Contact your dealer
	Tires improperly inflated	Adjust air pressure to 8 - 12 psi (55 - 83 KPa)
	Hydraulic pump faulty	Contact your dealer
Mower creeps when parking brake engaged	Steering linkage out of adjustment	Adjust steering linkage
	Brakes need adjustment	Adjust parking brakes
There is abnormal vibration	The engine mounting bolts are loose	Tighten the engine mounting bolts
	The engine pulley, idler pulley or blade pulley is loose	Tighten the appropriate pulley
	The engine pulley is damaged	Contact your dealer
	The cutting blade(s) is/are bent or unbalanced	Install new cutting blade(s)
	A blade mounting bolt is loose	Tighten the blade mounting bolt
	Spindle bearing is worn or loose	Replace or tighten spindle bearing
	A blade spindle is bent	Contact your dealer
Blades do not rotate	The deck drive belt is worn, loose or broken	Install a new deck drive belt
	The deck drive belt is off the pulley	Install the deck drive belt and check for a reason
	Electric clutch is not engaging	Check and/or replace 10 amp fuse. Contact your dealer

SYMPTOMS	PROBABLE CAUSES	SUGGESTED REMEDIES
Uneven cutting height	The blade(s) are not sharp	Sharpen the blades
	A cutting blade(s) is/are bent	Install new cutting blade(s)
	The deck is not level	Level the deck per the <i>Deck leveling and height adjustment</i> section of the General Service Manual
	An anti-scalp wheel is not set correctly	Adjust the height of the anti-scalp wheel
	The underside of the deck is dirty	Clean the underside of the deck
	Tires improperly inflated	Adjust air pressure to 8–12 psi (55–83 KPa)
	A blade spindle is bent	Contact your dealer
	Flex Forks [®] are installed	After initial break-in period, level the deck per the Deck Leveling section of the General Service Manual.

STORAGE

When storing the unit at the end of the mowing season, the mower, engine, and battery should have the following items serviced before storage.

If the mower has been stored for an extended period of time, follow the new season preparation steps before beginning operation.

General Mower Preparation for Storage

1. Remove all grass, dirt, and trash from mower and cutting units.
IMPORTANT: Wash the machine with a mild detergent and water. Do not pressure wash the machine. Avoid excessive use of water, especially near the control panel and engine.
2. Clean mower and deck and touch up all scrapes with touch-up paint.
3. Replace air filter element.
4. Check thoroughly for any worn or damaged parts that need replacing and order them from your dealer.
5. Thoroughly lubricate machine, according to the *Maintenance* section.
6. Block mower up so weight is off tires. Check tire pressure and inflate to proper operating pressure.
NOTE: Do not deflate tires.
7. Perform separate engine and battery preparation as listed below.
8. Store mower in a clean, dry place.

Preparation of Engine for Storage

If the vehicle is to be unused for an extended period of time (30 days or more), the engine will need to be prepared for storage. Use the following procedures before storing the vehicle.

IMPORTANT: Refer to the *Fuel Handling Precautions* section of this manual for important safety information before proceeding.

1. Fill the fuel tank(s) with fresh fuel.

WARNING ⚠

To prevent carbon monoxide poisoning, operate the engine in a well ventilated area only.

2. Run the engine for a minimum of 10 minutes.

WARNING ⚠

Allow the engine to cool before changing the engine oil. Use caution when changing the engine oil as it will be very hot. You should wear the appropriate protective gear to avoid being burned or exposed to engine oil.

3. Drain the oil from the crankcase while the engine is still warm.
4. Replace the engine oil filter.
5. Refill with fresh oil of the proper viscosity. Hustler® Motor Oil is recommended.
6. Check the oil filler cap and fuel cap to make certain they are securely in place.
7. Refer to the engine owner's manual for more information.

Preparation of Battery for Storage

When the machine is to be unused for long periods, it is best to disconnect the battery and remove it from the unit. At this time perform the following battery maintenance:

1. Remove the battery from machine.
2. Clean the battery, terminals, and cable connectors.
3. Charge the battery, if necessary.
4. Store the battery in a cool, dry place (do not expose to freezing temperatures).
5. Always keep the battery fully charged. Especially important to prevent battery damage when the temperature is below 32°F (0°C).

New Season Preparation

Before starting the mower following post season storage, the following service is required:

1. Clean mower, removing trash and dirt accumulation.
2. Check engine oil and hydraulic oil levels.
3. Install fully charged battery and attach the battery cables.
4. Fill fuel tank(s) with fresh fuel. Run machine at half speed for 5 minutes, checking operation of steering control levers. Stop engine and check for oil leaks, loose fittings and so forth.
5. Tighten any bolts that have loosened and make sure all hair pins, cotter pins and clevis pins are in place.
6. Install all safety shields and review safety precautions listed in this manual.



At start of new season always check that fresh oil has been added to machine. If oil is drained at season's end and not replaced, engine damage will result.

7. Check and inflate tires to 8–12 psi (55–83 KPa).
8. Refer to engine manual for more information.

INDEX

	PAGE		PAGE
Air Flow Baffles	3-11	Mower Operation	3-7
Air Restriction Indicator	4-6	New Season Preparation	6-1
Anti-scalp Wheels	3-12	Operating Suggestions	3-9
Battery Service Precautions	2-5	Operation	2-2
Belts	4-6	Parts and Service	1-1
Children	2-4	Personal Safety	2-1
Control Panel	3-1	Possible Damage to ROPS	3-6
Controls	3-3	Preparation of Battery for Storage	6-1
Cooling System	4-6	Preparation of Engine for Storage	6-1
Deck Clutch Operation	3-11	Product Literature	1-2
Deck Cutting Height Adjustment	3-11	ROPS Inspection	3-7
Driving the Mower	3-7	Safe Operating Practices	3-1
Electrical System	4-2	Safe Operation	2-1
Flex Forks®	3-11	Safe Servicing Practices	4-1
Flex Forks® Break-In	4-1	Safety and Instructions Decals	2-6
Fuel Handling Precautions	2-5	Safety Start Interlock System	3-4
Fuel System	4-3	Seat Adjustment	4-8
General Mower Preparation for Storage	6-1	Seat Belt Maintenance	3-6
Hydraulic Oil Heat Exchanger	4-3	Service Introduction	4-1
Hydraulic System	4-2	Service Precautions	2-4
Lubrication	4-1	Slope Guide	2-13
Maintenance Locator Chart	4-13	Slope Operation	2-3
Maintenance Record	4-15	Steering Control Lever Adjustment	4-10
Maintenance Schedule	4-11	Tires	4-1
Master In-line Fuse	4-2	To the New Owner	1-1
Model and Serial Number	1-1	Torque Values	4-1
Mower Blade	4-7	Using a Ramp	2-3
Mower Blade Maintenance	4-7	Using this Manual	1-1
Mower Blade Maintenance Precautions	2-5	Warranty Registration	1-1
Mower Blade Replacement	4-8		