

M U L C H E R



RADIO
CONTROLLED



Operator's Manual

MODELS:

X-Rot



BHV
Barbieri Hybrid Vehicle

ENGLISH

A - INTRODUCTION**INTRODUCTION**

This handbook must be considered as part of the machine. The seller of new and second-hand machines must record in the selling document that this booklet has been given along with the machine.

PICTURES USED IN THE HANDBOOK

Before starting use this machine, it is necessary to read carefully this hand-book, learn and observe all the safety rules indicated with the following symbols.

DANGER

This symbol is used to highlight an important safety information. If this information is ignored, people are in danger either of possible injures - even serious ones - or death.

In these messages are also described the normal precautions which have to be taken to avoid the danger.

Ignoring these precautions can cause serious damages to the machine.

ATTENTION

This warning is used in the handbook safety messages when the danger can cause minor or moderate damages and injuries.

The message can be used also for dangers which can cause damages to the machine or its components.

IMPORTANT

It is used for precautions which have to be taken to avoid operations which can shorten the life of the machine or of its component.

NOTE

This word is used to highlight information which refers to operations in progress.

Any time you see these symbols, whether on the machine or on the following of this manual you must pay attention to avoid danger to yourself and to other people.

Following some rules suggested by the common sense, you will avoid any break risk and your machine will function longer and more efficiently.

B - CONDITION AND PROPER USE**DEFINITION OF PROPER USE**

- This machine have been designed for grass cutting and weed control in agriculture and public green, flat and sloped areas.
- The exact observance of use conditions, maintenance and reparation are the essential element for a correct use.
- The machine should be used, maintained and repaired only by people who have knowledge of the security rules.
- The general rules about accident prevention and public road circulation rules should be respected

IMPROPER USES

- Any other use is not allowed. The manufacturer is not responsible for damages caused by any use than the intended one. The user is fully responsible for any possible risk.
- Each arbitrary modification carried out on the machine could release the manufacturer from the responsibility for any damage or accident derived by the machine.

ONLY ONE OPERATOR

The machine was designed to be used by one operator only. The presence of other people in the closeness could be dangerous for the safety of both user and people.

ACCESSORIES ON THE MARKET (ONLY IF AUTHORIZED)

Any use of accessories different from the authorized ones by the manufacturer is not allowed. For further applications different from the authorized one or in case of misunderstanding of this handbook, please contact the technical department of the manufacturer.

BARBIERI s.r.l. - Technical department
36040 SOSSANO - (VI) - ITALY
Tel: 0444/885722 - Fax: 0444/885482
e-mail support@barbieri-fb.com

Descriptions, figures and technical features mentioned herein are non-binding for the Manufacturer. These are mentioned as mere information. The Manufacturer reserves the right to make any change at any time without notice, to improve the quality of the products without being bound to update this publication.

C - INDEX OF CONTENT**MACHINE IDENTIFICATION**

- o Chassis number
- o Type and number of the engine
- o Dimensions

SECTION 1 - TECHNICAL DATA

- 1.1 Technical data
- 1.2 Noise
- 1.3 Vibrations

SECTION 2 - SECURITY RULES

- 2.1 Safety devices
- 2.2 Safety advices

SECTION 3 - MACHINE PREPARATION

- 3.1 Packaging and endowment
- 3.2 Preliminary tests

SECTION 4 - CONTROLS

- 4.1 Name of the Major Components

SECTION 5 - RULES FOR A SAFE USE

- 5.1 Connect the Radio Control
- 5.2 Engine start
- 5.3 Engine stop
- 5.4 Drive
- 5.5 Drive in a slope
- 5.6 Brakes system and Parking
- 5.7 PTO (Mowing blade switching ON)
- 5.8 Cutting height adjustment
- 5.9 Aux port
- 5.10 Controls during the use
- 5.11 In and out of the work field
- 5.12 Safety in work field

SECTION 6 - TROUBLESHOOTING**SECTION 7 - MAINTENANCE**

Main Maintenance components

Lubrication Points

Electric scheme

- 7.1 Tests before using
 - 7.1.1 Control of the engine oil
 - 7.1.2 Engine's air filter
 - 7.1.3 Refuelling
 - 7.1.3 Control of crawler tension and conditions
 - 7.1.4 Radio Control battery charge
 - 7.1.5 Control Cutting blades
- 7.2 Maintenance and adjustments
 - 7.2.1 Lubrication program
 - 7.2.2 Changing of engine oil and filters
 - 7.2.3 Control and replacement of gear box oil
- 7.3 Notice for disposal

SECTION 8 - TRANSPORT

- 8.1 Transport to the work field

SECTION 9 - COMPLAINTS AND WARRANTY**SECTION 10 - CERTIF. OF CONFORMITY**

D - IDENTIFICATION NUMBER

In case of a trouble, when You contact Your dealer for a reparation or to ask for spare parts, it is necessary to identify the machine with the following data:

- Model and chassis number
- Engine type and number

MODEL AND CHASSIS NUMBER

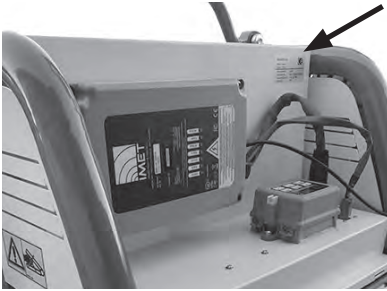

Fig 1

ENGINE TYPE AND NUMBER (Honda engine)



Fig 2

DIMENSIONS (cm)

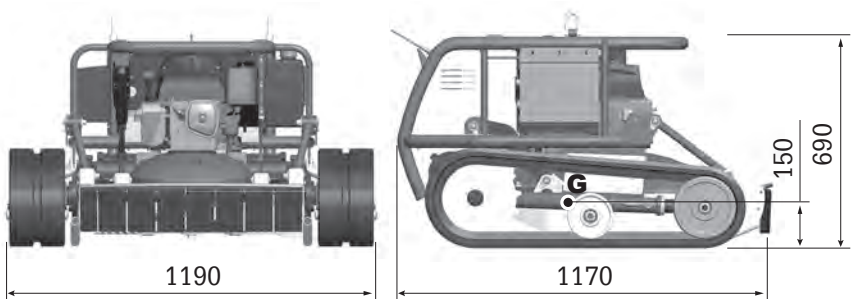

Fig 3

1 - TECHNICAL DATA
1.1 Technical data

ENGINE		GENERATOR	
Make	HONDA	Generator 1	Phases 68VAC - 80A
Model	GXV 390	Generator 2	Monophase 17VAC - 10A
Engine type	Air cooled 4S OHV petrol vert.		
	Pressure lubrication		
Bore x stroke	88 x 64 mm	CUTTING DEVICE	
Displacement	389 cm ³	Type	Mulcher back discharge
Compression ratio	7.7 : 1	Blade type	2 floating Multy-cut - 2600 rpm
Net power	7.6 kW (10.2 HP) / 3 600 rpm	Cutting Width	75 cm
Cont. rated power	5.2 kW (7.0 HP) / 3 000 rpm	Height Adjust.	30 ÷ 150 mm stepless electric
Max. net torque	24.2 Nm / 2.47 kgfm / 2 500 rpm	Drive	By belt with EM Clutch (Ogura)
Ignition system	Transistorised		
Starting system	Electric START	RADIO CONTROL 2,4 GHz	
Air Filter	Paper + Foam cartridge	Transm. technology	AFA (Aut. Freq. Adjustment)
Fuel tank capacity	10 Lt	Controls	Optic - contactless
Fuel cons. @ rat power	2.5 L/hr - 3 000 rpm	Radio transm. distance	200 m
Engine oil capacity	1.1 Lt	Regulations compl.	Dir R&TTE 1999/5/CE 2006/42/CE PLe categoria 4 /SIL 3 ISO 13849-1:2008 / EN62061:2005"
		Weight	1,3 Kg
TRANSMISSION		DIMENSIONS	
Type	Hybrid-Electric motors 48V with reduction gear	Overall dimensions	119 x 117 x 68
Control	Stepless electric - speed control	Weight	320 Kg
Speed Range/ Max	0÷ 8 Km/h	Soil pressure	115 g/cm ²
Max Slope	35° Uphill - Longitudinal 45°	Crawler contact area	(17,5x80x2) = 2800 cm ²
Tilt ang/h-gravity point	65° / 15cm		
Motor type	Brushless Perm. Magnetes		
Power supply	3 Phases		
Motor power	1 kW		
Driver	BHV - 48V 60A		

1.2 Noise

The noise level was obtained during the equipment in action, in neutral position and the results are the following:

Honda engine GXV 390 (4 strokes) with original muffler

- Acoustic pressure level (LpAm) 92,7 dB(A)
- Acoustic power level (LwA).....107,3 dB(A)

1.3 Vibrations

The vibrations level was obtained with the machine at work at 3060 rpm (85% of the nominal condition of 3600 rpm) and the results are the following:

- Not applicable

LABELS AND WARNINGS POSITION

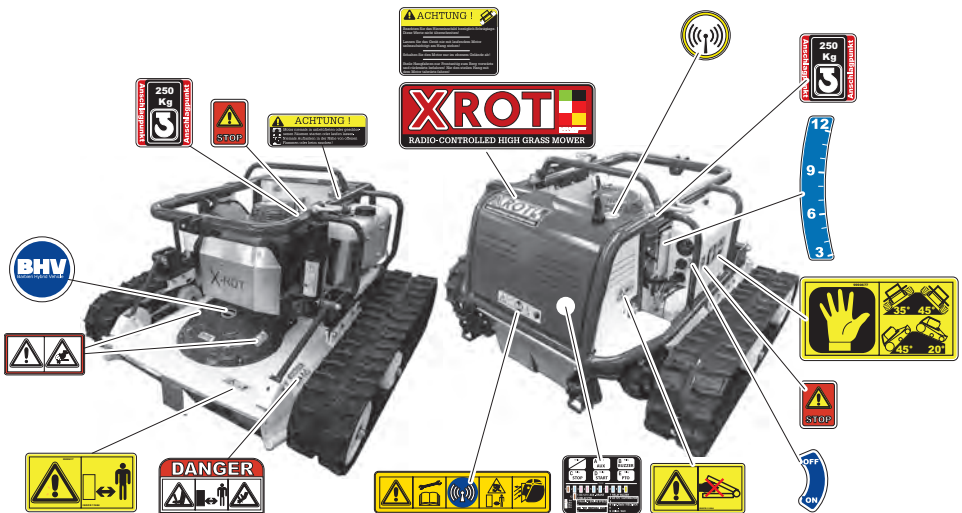

Fig 4

2 - SAFETY NORMS

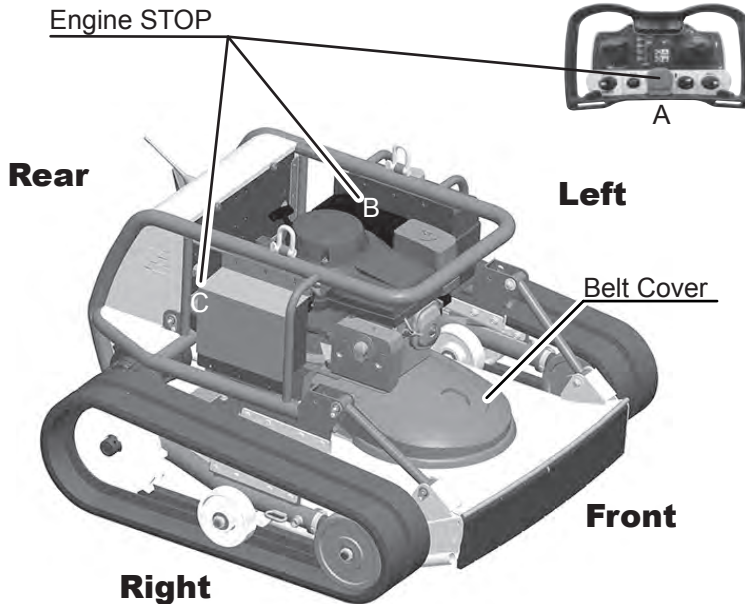

Fig 5

2.1 SECURITY DEVICES

The terms “FRONT” - “REAR” - “RIGHT” - “LEFT” used in this handbook and in the spare parts catalogue, are referred to the machine as shown in Fig. 5

SAFETY DEVICES

The machine is equipped with a series of safety devices to comply with the Machinery Directive.

More precisely the following devices are provided for:

- 1- engine STOP device (B) (fig.5)
- 2- engine STOP on the remote control (A) (fig.5).
- 3- engine STOP on starting key (C) (fig 5)
- 4- Automatic brake system in case of engine stop
- 5- Front and rear shield to stop the object thrown by the blade
- 6- Automatic switching OFF of the blade in case of engine stop
- 7- Automatic engine stop in case of loosing of radio control
- 8- Transmission belt cover

The most important warning labels are placed near to the danger around the machine. Be sure to understand the meaning of the lables in order to use a proper behavior to avoid any danger operation.

These labels are very important for the safe use of the machine along the time. Keep these lable clean and in a good condition. In case of damage or lack of such a lables it is mandatory to replace them with - original ones.

CAUTION LABEL AND WARNINGS

Besides CE mark, safety pictures and indications are applied on the machine and mentioned in the fig. 4.

WARNING: BEFORE SERVICING

Read the technical instructions in the operation manual before servicing the machine.



WARNING: RISK OF INJURY

Stay away of the discharge opening of the mower deck because stones or other hard objects ejected from the mower may hit you

Use visor to protect from flying object



WARNING: RISK OF ENTANGLEMENT

Stay clear of the belt while it is running



DANGER FOR HAND AND FEET:

Cutting blade: Keep hands and feet away.



WARNING:

Radio controlled machine.

Keep away if engine is running



WARNING:

Danger of hand crushing



WARNING:

Exhaust gases are poisonous!

Never start the engine in not ventilated room



WARNING:

Petrol gases are explosive.

Do not refueling with free flames, sparks or while smoking



ATTENTION:

Do not work in slopes over the limits

Stability and engine lubrication can be lost



- 1) Before starting the engine, be sure that the SAFETY DEVICES are well working and fitting. Without these cares the operator might work in a danger situation.
- 2) This machine has been designed and manufactured for being used by one operator only who hold the Radiocontrol. Any other use is not permitted!
- 3) It is important to ensure a safe distance between the operator and the machine in the operating area (see cap.5.12)
- 4) Before the machine is operating, read the Use and Maintenance manual thoroughly, so that you are fully aware of all the operating controls and safety aspects of the machine.
- 5) No modification to the machine or use of not genuine spare parts can be done without the Manufacturer consent. This praxis can lead to very dangerous and unpredictable situation and will anyway nullify the warranty.
- 6) Do not under any circumstances transport people or objects on the machine.
- 7) Before using, check that all the controls are in good working order.
- 8) Move the controls gradually; sudden engagement could cause the loose of stability of the machine.
- 9) Check anytime that all parts all well fixed
- 10) This machine have not to be used by children or inexperienced persons. Operators that are not duly trained of people that are under effect of alcohol or other substances.
- 11) Before operating the machine, check that the area is clear and free of debris and that there are no people within the working area (danger zone). The operator, will be held responsible for the safety of third parties, if these are found within the working area of the machine. Do not use the machine under these conditions.

- 12) Do not use the machine when you are tired
- 13) Keep away from cutting blades at all times while the machine is in operation.
- 14) Use only genuine spare parts and accessories to guarantee the security and functioning of the machine.
- 15) Stop engine before refuelling
- 16) Handle the fuel with care to avoid spilling on the machine; clean any spillage immediately.
- 17) Avoid overfilling the fuel tank
- 18) Plan well your work before starting
- 20) The area next to the engine exhaust will most likely reach temperatures above 80°.



ATTENTION! Danger of scalding.

- 21) Keep the area of work clear and clean.
- 22) Only use the machine in clear visibility.
- 23) If you hit any objects during work, stop the machine and check for any damage immediately.
- 24) It is advisable to keep a first aid kit
- 25) The speed of the machine must be convenient to the environment conditions
- 26) Never do maintenance or cleaning works when the engine running.
- 27) When possible, avoid working up or down hill .Always travel across the slope.
- 28) Do not work on very steep slopes (max.70%).

- 29) During use, keep the hot sections of the engine (i.e. cylinder head, exhaust, etc.) clean to avoid a build up of debris that will overheat the engine.
- 30) Whenever possible, stop the machine on level ground.
- 31) Park the machine where children or unable people can't reach it: stop the machine and remove the Start key from the dashboard.
- 32) Do not leave the machine with the engine running. Reach a flat ground and stop the engine.
- 33) Follow carefully the maintenance instructions and replace always the worn parts if necessary.
- 34) Storage the machine after cleaning it, only.
- 35) If any, it is necessary to take heed of the specific safety norms in force in the Country where the machine is operating.
- 36) Never refuel in confined places, in vicinity of open flames or near the source of sparks. No smoking during fuel handling!
- 37) Never start the engine in a closed place. Exhaust fumes contain poisonous carbon monoxide, so sufficient ventilation should be provided when starting the engine indoors.
- 38) After storage of the machine for a long period, make a deep cleaning and lubricate the machine according to the lubrication program.

3 - MACHINE PREPARATION**3.1 Packaging and endowment**

Fig 6

The machine is supply with:

- 1 x Basic Unit X-Rot*
- 1 x Radio Control*
- 2 x Lithium battery for Radio control*
- 1 x Battery charger*
- 1 x Radio control's hanging belt*
- 1 x User Manual*
- 1 x Engine user manual*

Before to use the machine, check the fuel and engine's oil level and read carefully the instruction manual about the safety regulation and the procedures to start and control the machine.

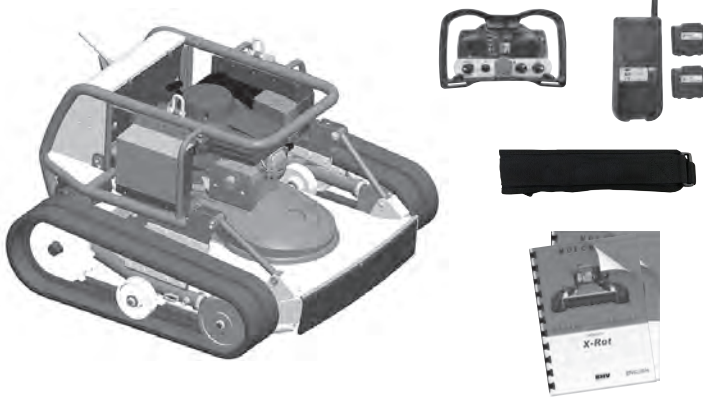
3.2 PRELIMINARY TESTS

Before using the machine for the first time, it is necessary to do the following checks:

- Engine oil level (see Cap. 7.1.1)
 - Fuel level in the tank (see Cap. 7.1.3)
 - Battery charge on the Radio receiver (see Cap. 7.1.5)
- The engine oil should be always on the mark of the upper level. Lack of oil will decrease the engine performance on the slope.
- The fuel level should be near to the max but not reaching the collar of the tank. In case of slope the fuel can spill out and create a danger of fire.
- The 2 battery set have to be charged before to start any work. One battery should be enough for one day operation but the 2nd one is required in case of need.

4 - COMPONENTS AND CONTROLS

4.1 NAME OF MAJOR COMPONENTS (fig.7)

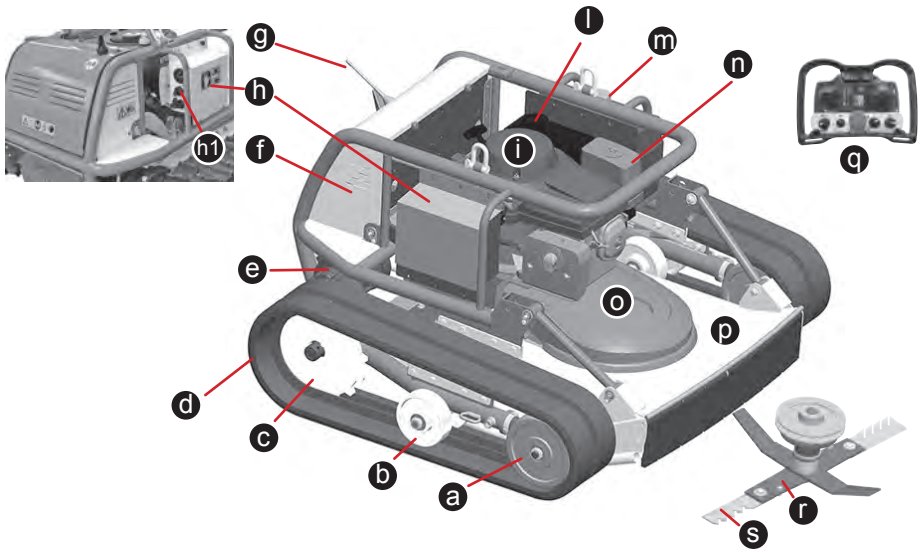

Fig 7

Basic Unit: Identification of the main components.

- | | | |
|---------------------|----------------------------|-------------------|
| a) Tensor wheels | g) Antenna | n) Air filter |
| b) Crawler's roller | h) Battery case | o) Belt case |
| c) Drive wheel | h1) Start key | p) Mower deck |
| d) Crawler Belt | i) Engine - Recoil starter | q) Remote control |
| e) Drive motors | j) Emergency switch | r) Blade support |
| f) Electric cabin | k) Fuel Tank | s) Blade |

4.2 ENGINE (fig.7 - i)

The machine is equipped by a high quality petrol engine made in Japan and designed to grant a long operating life. The engine is provided by an electric start. To start the engine follow the procedure of Cap. 5.2.

The engine is also provided by a forced lubrication system which help to work in a sloping areas, nevertheless it is highly recommend not to exceed the 35°. The instruction of the max angle are reported on the bottom of the radio control.



IMPORTANT

Do not leave the machine in the slope with the engine running. The lubrication can be insufficient and cause the engine failure.



ATTENTION

Never stop the engine while the machine is on the slope. The engine stop will cause the switching off of the drive motors and the lose of the braking torque. The machine can start slowly sliding downhill without control.

The first 50 working hours represent the run-in of the engine. During this first period we recommend not to use the machine at the full power.

It is also necessary to leave the engine running for few minutes at the idle speed for warming after starting. A sudden use at the max power just after starting cause a thermal shock to the engine components.

4.2.1 AIR FILTER (Fig.7 - n)

The engine is equipped by an air filter. In case of dry grass and dusty environment the air filter have to be cleaned very often (every 2 hours). If some flying grass are trapped by the net of the recoil starter (Fig. 7 - i) it means that probably also the air filter need to be cleaned out. (see cap. 7.1.2). The clogging of the air filter can cause a lose of engine power. In normal condition, the air filter should be cleaned every day.

4.2.2 FUEL TANK (Fig.7 - m)

The fuel tank have a capacity of 10 litre of petrol and should assure 4 hours of operation. Before to start any work remind to fill up the fuel tank. A reserve of fuel of 3 litres (marked by a pilot light on the radio control) warn that it is time to refuel. stop working and move the machine in a flat hard soil for fill it up.

4 - CONTROLS

! DANGER

The engine stop can be dangerous in case of slope. the stop of the engine cause the loosing of control of the electric motors. In case of slope the machine will start to move downhill.

! DANGER

Pay attention while refuelling: The gas of petrol are highly explosive. Do not attempt to refuel if somebody are smoking or in presence of sparks or open flames.

4.3 MOWER DECK (fig.7 - p)

The mower deck has a special design to reduce the power required. It is connected directly to the engine by belt and disconnected by an EM clutch.

The engagement of the Mower can be done if the engine is at a suitable speed. (see Cap.5.7). The blade system depend from the type of work: multi-cut for a perfect mulching result and a stronger cutter for heavy duty operations. The cutting height can be adjust from the remote control and it is visible from an indicator on the right hand side of the machine (see Fig. 8). For maintenance of EM Clutch, Blades and transmission Belt please refer to Cap. 7.2.7.

4.4 ELECTRIC SYSTEM

The driving system of this mower is electric. The alternator driven by the petrol engine generates an electricity supply voltage of 48 V in a range (Extra-low voltage - **ELV**) which carries a no risk of electrical shock.

The crawler are then driven by 2 brushless electric motors controlled electronically by 2 inverter which follow a sophisticate software that makes the machine easy to use and flexible.

The electric cabinet on the back of the machine have a easy access to the radio receiver and to the fuse and relays boxes (Fig 9). The electric system has a waterproof grade of **IP 54**.

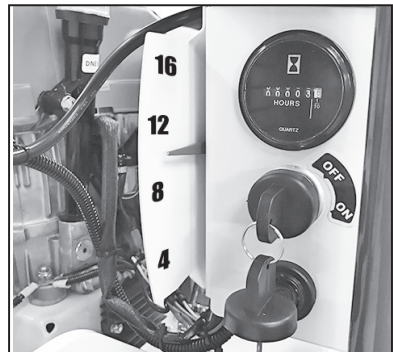

Fig 8

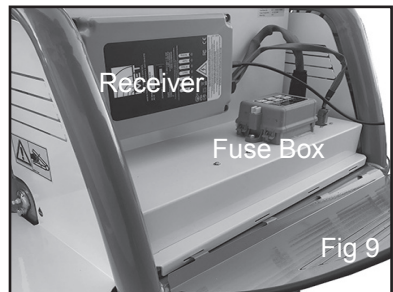

Fig 9

4.5 TRANSMISSION

The transmission of the power to the crawler are made by 2 strong and silent gear reducers. The portal shape of the transmission allows to keep very low the centre of gravity of the machine which is 15 cm off the ground, only. The technology of these electric motors grants the maximal torque also at a standstill. These 2 features make this machine suitable to work in very sloped ground. Moreover in case of electric power failure, a passive breakage device save the machine from running downhill without any control.

4.6 REMOTE CONTROL

The remote control is a heavy duty and reliable unit which allow to carry out all the controls and the adjustment of the machine. It works on a frequency of 2,4 GHz with the Transmission technology AFA (Automatic Frequency Adjustment) that automatically shift to a new free channel in case of disturbs on the transmission.

CONTROLS OF THE RADIO TRANSMITTER

Fig 10



- | | | | |
|---|---------------------------------|----|---------------------------------------|
| 1 | Radio connection button | 6 | Drive control Forw./Rev. - Left/Right |
| 2 | Engine Start button (with (1)) | 7 | Aux actuator adjustment lever |
| 3 | Engine's throttle | 8 | Drive reference inverter switch |
| 4 | PTO Switch button | 9 | Alarm switch (motorstop) |
| 5 | Cutting height adjustment lever | 10 | Aux socket switch |

5 - RULES FOR A SAFE USE

5.1 CONNECTING THE RADIO CONTROL

Turn the Starting Key switch to ON position. The buzzer will start to sound to warn that the Radio control is not connected. To connect the Radio Control press the Green Button 1 (Fig.10) on the left hand side of the remote control and wait until the 2 warning lamps green (a) and blu (b) start to blink; than push again the green button 1 (Fig.10) and keep it pressed 1 second and release it. The warning lamps stop blinking and the Buzzer stop to sound : the radio control is now linked .

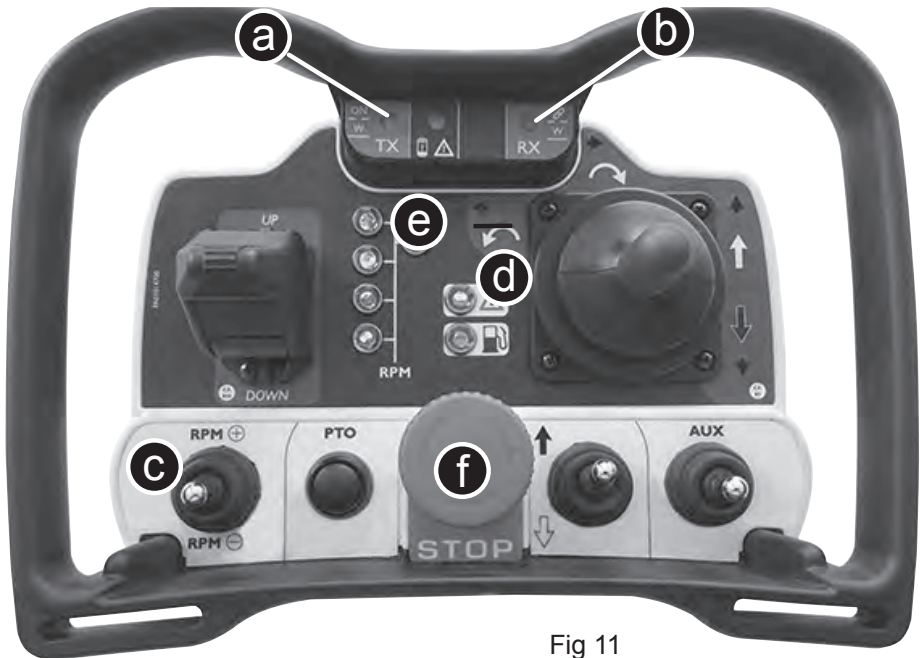

Fig 11

5.2 ENGINE START (fig.11)

Move the throttle lever up (Fig 11 (c)) until the Choke Warning Light (d) light up. Push both Buttons on the left hand side (Fig.10 (1) and (2)) until the engine starts. Move the throttle lever down until the Choke Warning Light (d) turn off.

NOTE: If the warning light does not turn ON, the motor will not run (Only for Honda Engine).

-  3200 rpm
-  2700 rpm
-  2200 rpm
-  1700 rpm

Now the engine speed can be adjusted and the value is shown from the warning light column (Fig 11 (e)).

NOTE: If the throttle is set over the max, the "Choke" warning light (d) switch ON and the engine emits smoke and "stutters" or "stumbles".

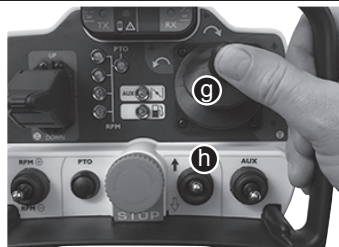

Fig 12

5.3 ENGINE STOP (fig. 11)

To stop the engine push anytime the Red Alarm Button (Fig 11 (f)) and the engine will suddenly stop. After stop, remind to release the emergency Button in its normal position. The engine can be turned OFF also by Alarm Button on the top of the machine (Fig.7 (l)), turning the Star Key (Fig 7 (h1)) OFF or if the machine lose the Radio connection with the remote Control.

NOTE: If possible it is always recommend to move the machine in a flat ground before to stop the engine. In case of emergency STOP as soon as possible start the engine and move the machine in suitable flat ground for parking.

Fig 13

5.4 HOW TO DRIVE (fig.12)

Check that the lever (h) is set UP. This lever reverse the motion. Move (A) the Joystick (g) FORWARD gradually and continuously. The machine will move ahead. The machine can be controlled easily by one finger which control the speed and the direction. The speed is also controlled by the displacement of the Joystick lever.

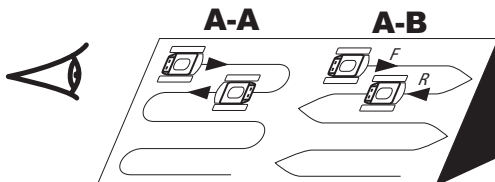
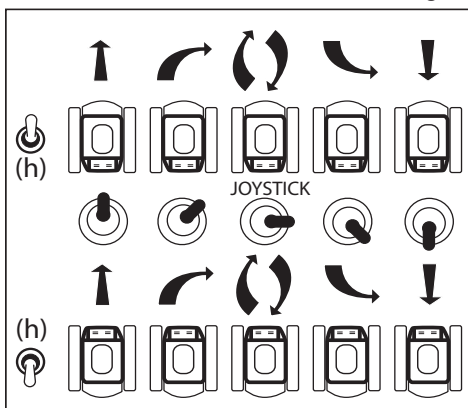

Fig 14

5.5 HOW TO DRIVE IN A SLOPE

In a slope it is recommend to drive in a longitudinal way and (if possible)with the right hand side downhill. To work on the slope area it is not necessary to change direction because the machine can work in both direction. So the suggested path is A-B as represent in the Fig 13.

In case it is necessary to work in a A-A path, it is provide a "REVERSING SWITCH" Fig 12(h) which make easier to drive as the machine will follow the Joystick direction. (see Fig 14 the drive direction with the 2 positions of the switch (h)).



5.6 BRAKE SYSTEM AND PARKING

The machine is supplied with an automatic e-motor brakes which stop the machine while not driving. This brake system works if the engine runs and all the control systems are working. For this reason, if you are going to stop the engine it is recommend to park the machine on a flat ground; in case of hazard or for any other reason that cause the engine to turn off, a second passive brake system comes into operation. The secondary brake system is not effective as the first one so in case of extreme slope it is recommend to start the engine again and to move the machine to the nearest flat ground.

5.7 PTO (Mowing blade - switching ON) (Fig 15)

If the machine is in running order is now possible to start the mowing blade. The blade starting require a big energy, therefore it is provide a control to prevent the blade starting with a low engine speed.

Adjust the engine speed by the throttle (c) over the 2800 rpm (green leds (a) - Fig 15). With the green light it is possible to start the PTO by pressing the button (b).

The green led (d) shows that the blade is rotating.

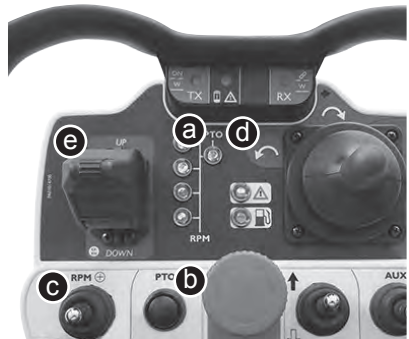

Fig 15



Before to start the PTO be sure that you have taken all the precautions stated in para. 5.10 especially:

- the blade should be free (non in contact with the ground)
- no object that can be through from the blade lays on the working area
- no people or pets are in the DANGER AREA (see para 5.12)

	3200 rpm
	2700 rpm
	2200 rpm
	1700 rpm

5.8 CUTTING HEIGHT ADJUSTMENT (Fig.15)

It is possible anytime to control the cutting height from the remote control. In case of thick high grass, it is recommend to adjust the mowing deck to 100 mm from the ground in order to allow the grass to exit. If necessary, make second stage with a lower height setting. To lift the blade up, move upwards the control lever (e). To lower the blade, move the control lever (e) down.

5.9 AUXILIARY PORT

The machine can be equipped by an implement such as sprying pump, brush cutter, side arm, ect. These implements can be controlled from the remote control as well. The implements should be plugged in the socket in the front of the left hand side of the machine.

5.10 CONTROLS DURING THE USE

The machine require a very few maintenance operation as it have been design to be maintenance free. Nevertheless as the machine is equipped by one engine it is necessary to mantein it and to make some controls everytime you use it. This machine normally works in a inaccessible areas and in case of undesired stop it can be hard to reach and restore the machine.

Before to start any work, control:

- Anything that was abnormal in the previous operations.
- the level of the Fuel. Replenish it every time
- the level of the oil of the engine: (near to MAX)
- clean the cartridge of the air filter
- the charge of the battery of the remote control
- the condition of the blades
- Oil leakage from mower gear case
- Loosen, broken or lost pins and clips
- deposits of grass and mud on the crawler's wheels.
- to reduce the fire hazard, and improve the cooling capacity, keep the engine, muffler (silencer), battery area, and fuel tank area free of debris
- After starting the engine confirm the operation of safety switches

5.11 ACCESS TO AND FROM THE WORK FIELD

A special care is necessary during the transportation and the access to the working field.

5.11.1 LOADING ONTO OR UNLOADING FROM A TRUCK

When loading the front mower onto a truck, turn off the truck's engine, apply the parking brakes to the truck, and chock the wheels to avoid unexpected moving of the truck or trailer.

When loading the machine onto a truck, lift up the mower deck fully and advance it straight at sufficiently low speeds. Drive it rearward when unloading it from the truck or trailer.

Use ramps with the same or better specifications mentioned below.

Specifications of the ramps

- | | |
|---|---|
| - Length | more than 4 times the height of the platform of the truck |
| - Width (effective width) | more than 30 cm |
| - Required quantity | 2 ramps |
| - Capacity (one ramp) | more than 250 kg |
| - Ramps should have anti-skid surfaces. | |

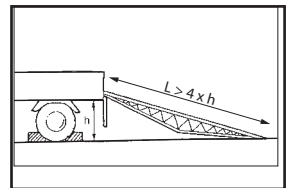

Fig 16

Park the truck on hard level ground. Hook the ramps securely on the platform of the truck with the top of the ramp level with the platform.

Bind the machine to the truck or trailer using the hitch points shown in the picture Fig 16.

The machine is provided by hanging hook to be placed on the working ground by a truck crane.

The machine weight is 320 Kg. Be sure to use belts and hook with a proper loading capacity.

5.12 SAFETY IN THE WORK FIELD

It is mandatory to follow these rules to not create danger for the operator and for people, pets or things around the operation area.

- a) Operate if you have a perfect control at your sight of the area of 20m radius around the machine, only. If the machine's moving area is not visible, change your position.
- b) Do not allow any people or animal to approach the machine. A miscontrol of the drive can cause severe injury to the people or some object can be thrown out from the mower blade and hit somebody. The **danger area** is shown in Fig 19.



DANGER

Do not allow for any reason the people to enter into the DANGER AREA. This recommendation include also the operator. Launched objects can cause severe injury.

- c) Check the working area to remove any object that can be danger for the machine.
- d) Place some warning tape or sign to alert people not to enter into the working area.
- e) Check the slopes and the soil conformation to identify some danger areas. Select the position to operate in order to have the best visibility and safer place.
- f) Avoid to perform maintenance in the work field because it is a dusty place. Moreover you get the risk to do excessive efforts and you don't have the necessary tools.

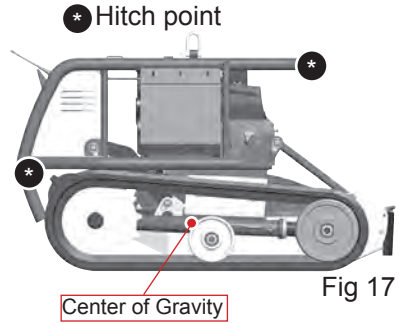

Fig 17



Fig 18

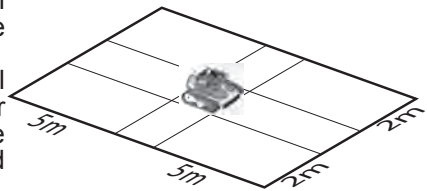

Fig 19 - Danger Area

SECTION 6 - TROUBLESHOOTING

6 - TROUBLESHOOTING

TROUBLESHOOTING			
GROUP	PROBLEM	CAUSE	REMEDY
Remote Control	It is not possible to connect	The key on the machine is turned OFF	Turn the key ON
		The mushroom emergency switch is not armed	Arm the switch in the Remote control
		The remote control's battery is low	Replace the battery and charge this one.
		If leds on receiver in the machine don't light on, internal fuse may be burned out	Replace the internal fuse
Power supply	No Bip tune on switch key turn ON	<ul style="list-style-type: none"> - Battery fuse is burned out - Fuse 1 in Fuse case is burned out - Machine Battery is low 	<ul style="list-style-type: none"> - Replace Battery fuse inside Battery Box - Replace Fuse 1 in Fuse Box - charge the battery
Engine	The engine don't start	The starter motor do not work	<ul style="list-style-type: none"> - Throttle to MAX until Choke warning light, is on. - Replace the Start Relay (E) - Replace Fuse 1
		<ul style="list-style-type: none"> - Choke is not activated - Starter relay burned out - Fuse of starter (FUSE 1) is burned out 	
		The starter motor turn but engine do not start	
	Throttle is not working	No petrol on the carburator drain screw	<ul style="list-style-type: none"> - Defective fuel pump - Crushed fuel pipeline - loose clamp
		<ul style="list-style-type: none"> - Actuator is not working - Actuator is moving 	<ul style="list-style-type: none"> - Check the cable XC3 - Check fuse 5 and 6 - Actuator is defective - Check the connecting rod
		Engine grumbles and make smoke	Choke is still engaged
Engine starts and stop - makes smoke	Oil level too high	Check the oil level and in case drain oil out	
Drive	The machine do not execute the command	One driver is not synchronize with the other	Switch off the engine and restart again
	The machine do not move at all	Communic. cable between drivesr is not connect	Verify the connection of the comm. cable
		Main Fuse (big ones) are melted	Replace the melted fuse
		Brake relay are defective	Remove all the brake relays and try again. If it is working, replace the defective relay with new one.
Heigh Adjust.	The Height adjustment doesn't work	<ul style="list-style-type: none"> - Actuator is not working 	<ul style="list-style-type: none"> - Check the cable XC1 - Check fuse 5 and 6 - Actuator is defective
		<ul style="list-style-type: none"> - Actuator is moving 	<ul style="list-style-type: none"> - Check the connecting fork
Mowing deck	High vibration and noise in the machine	The blade is broken or bended	Stop the machine and replace the blade

7 - MAINTENANCE

Main Maintenance points

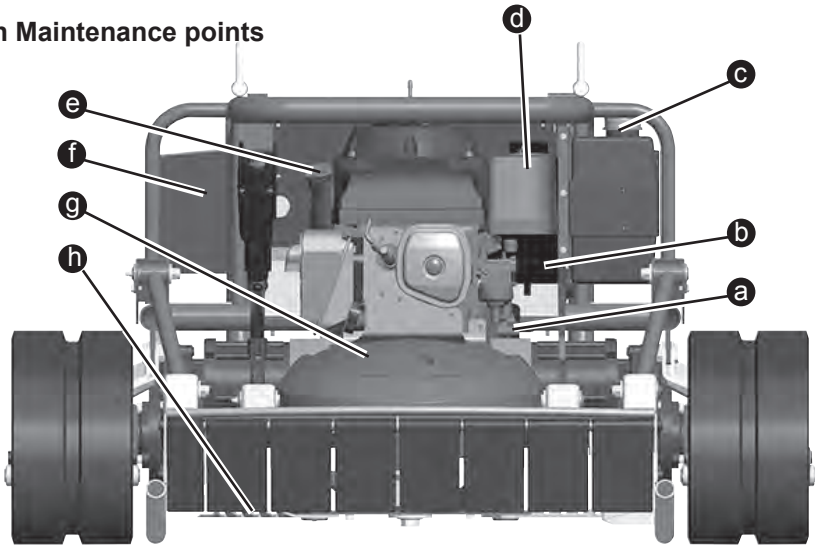
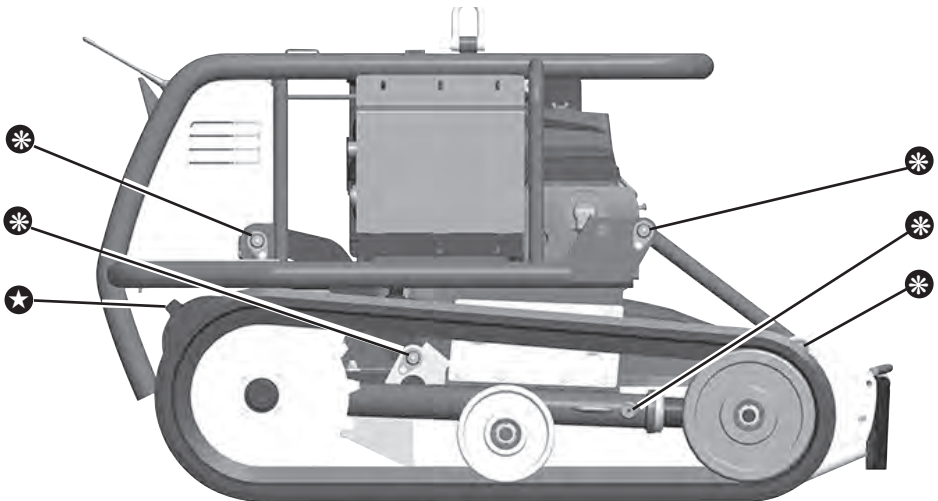

Fig 20

- | | | |
|-------------------------|---------------------------|---------------------|
| a) Engine oil Drain cap | d) Air Filter | g) Mower Blade belt |
| b) Fuel Filter | e) Engine oil filling cap | h) Mower Blade |
| c) Fuel tank cap | f) Battery | |

Lubrication Points



- * Grease Nipple
- ★ Reductor oil filling cap

Fig 21

Electric scheme

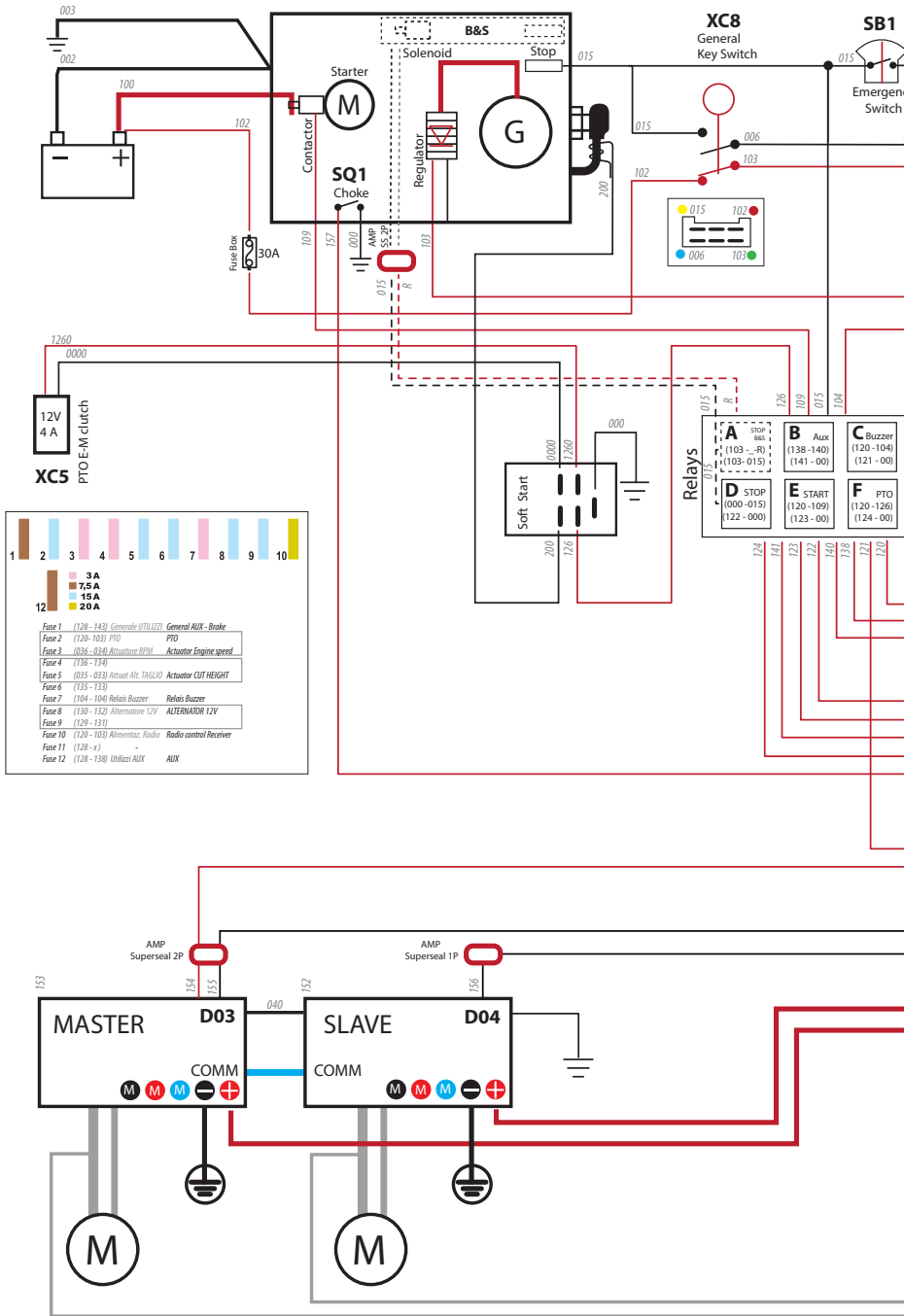

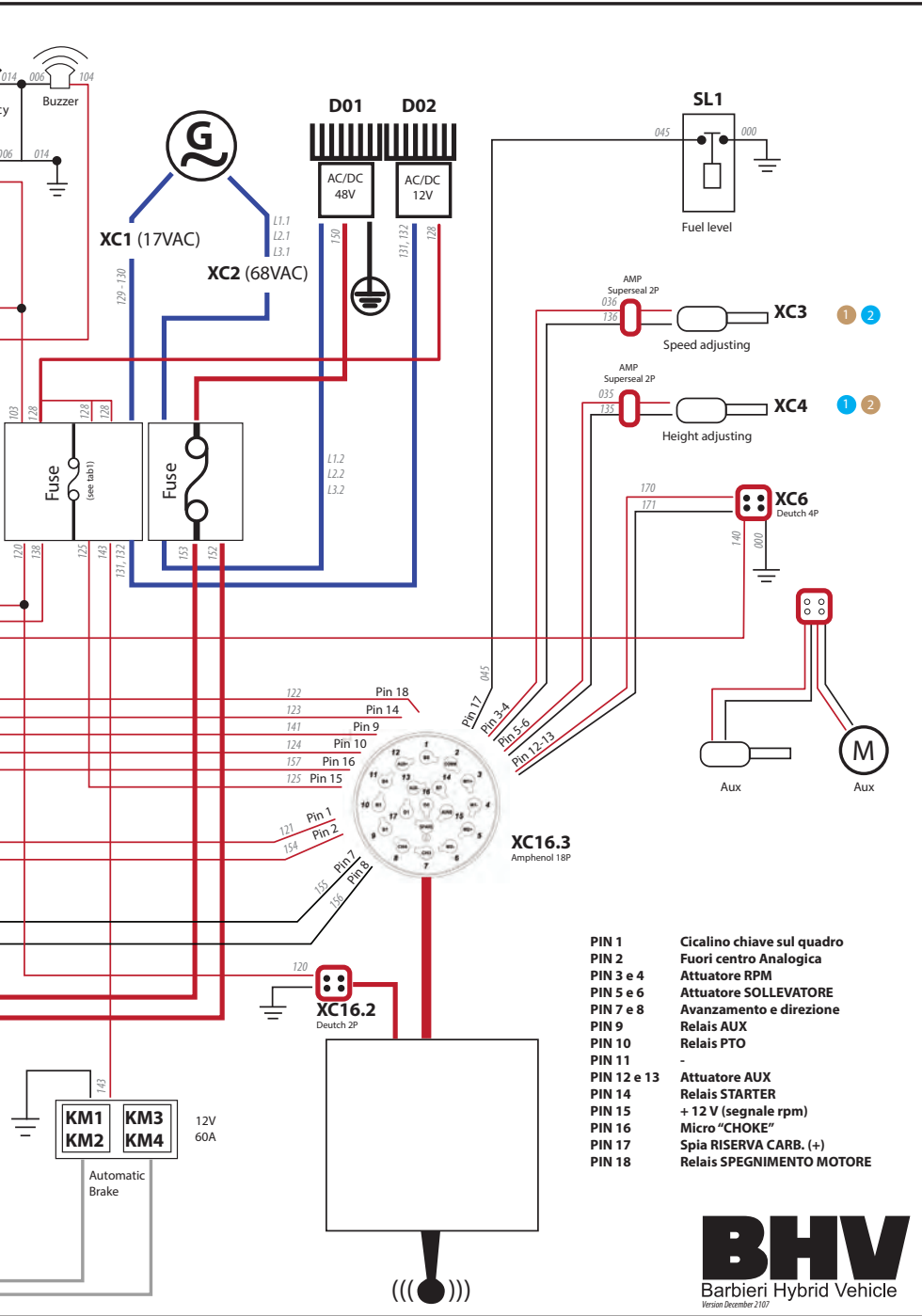

7.1 TEST BEFORE USE

7.1.1 Control of the engine oil (Fig 20 (e))

To check the engine oil it is necessary that the machine is on a flat hard ground. Remove the oil dipstick (e) and check that the oil level is near the upper mark. For more detail about engine lubrication please refer to the engine manual.



IMPORTANT

The oil level should never be under the MIN mark and not exceed the MAX level on the dipstick. The oil over the max quantity can damage the engine.

Fig 22

7.1.2 Engine's air Filter (Fig 20 (d))

For a good function of the engine it is important to check if the air filter or the cooling elements of the engine are free from clogging stubble deposited from the air flow. Clean often these elements in case of dusty and dry conditions.

7.1.3 Refueling (for safety instruction see Cap. 4.22)

Filling up the fuel tank is often a not easy and safe operation to do on the field, therefore it is highly recommended to check the level of the fuel tank before to start working. A full tank allows to work 4 hours.

Fig 23

7.1.4 Control of crawler tension and conditions

It is important to check the condition of the crawler to avoid they get out from the roller. The crawlers are equipped by an automatic tensor which apply the right force to the belt. If during this check the crawler appear lose verify if the crawler is damaged or if something block the tension of the front wheel.

A lose crawler can easily get out from its position.



7.1.5 Radio Control battery charge

The battery of the radio control is a critical component of the machine. A low charge battery do not allow to start the engine and the machine cannot be controlled. This is why 2 battery are provided for safety. It is highly recommended to charge the 2 batteries before start any operation.

ATTENTION

If the battery have low charge the engine will stop and the electric motors will lose their brake effect. If this happen in extreme slope the machine will start sliding downhill.

7.1.6 Control of the Cutting blades

The blade turn at a high speed so that a un-normal wearing or damage to one blade can cause a big vibration on the machine. Moreover the blade can lose its sharpening due to banging against a stone or any other hard

object layed on the field. For this reason it is necessary to control the blade condition before the operation.

7.2 MAINTENANCE AND ADJUSTMENT

7.2.1 Maintenance schedule and Lubrication program

		Replacement or servicing at authorized service facility recommended					REMARKS
*	▲	○	●	every 200h	every 500h	Long Parking	
		Clean or wash					
		Inspect replenish or adjust					
		Replace					
Before Operation		Initial 50h	every 200h	every 500h	Long Parking		
Engine Oil	○	●	●	●	●	●	Maintain specific level
Air cleaner	▲	▲	▲	●	▲	○	Keep fuel tank always full
Fuel	○						No dust or water inside
Fuel filter				●			
Battery condition			○			○	
Rubber pipes			○			○	
Remote control battery	○					○	Charge every time
Cutting blade BELT		○	○	●	○	○	Adjust tension
Cutting blade condition	○		○			○	Check unpair wearing
Transmission drive oil				*			
Crawler condition	○					○	
Grease up		○	○	○	○	○	
Bolts and nuts	○	○	○	○	○	○	
Electrical apparatus			▲			▲	
Safety switches	○		○			○	

7.2.2 Changing engine oil and filters

For the engine oil always refer to the instruction manual of the engine manufacturer. The first oil replacement has to be done after the first 50 working hours which represents the engine running-in period. This change remove the metallic suspended particles produced by the rotating parts. Let the engine running for some minutes to warming up.

Before starting the level checks or oil replacement, carry out a careful cleaning to avoid that external particles enter into the case.

Remove the cap with the dipstick (1) and the drain cap (2). Collect the exhaust oil into a bassin. Transfer the waste oil into a container suitable for its disposal. Close the drain cap end fill with new oil from the cap (1). SAE 10W-30 is recommended for general, all-temperature. Other viscosities shown in the chart may be used when the average temperature in your area is within the indicated range.

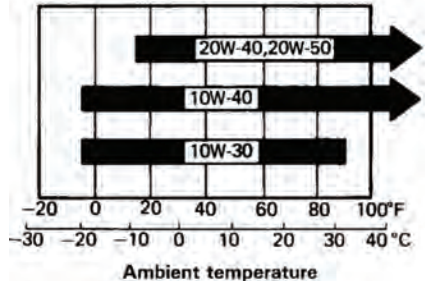

The Engine oil (Agip Rotra MP) SAE 10W/30. The quantity is 1.1 kg. Check the oil level as described in Cap. 7.1.1.

7.2.3 Control and replacement of gear box oil

The transmission oil must be replaced after 500 working hours unless some oil leaking appear on the gearbox. In this case it is necessary to repair the damaged gasket and replace the oil. This reparation have to be made by an authorized dealer.

7.2.4 Lubrication of Joints

Following the lubrication program, after the initial 50 and 200 working hours, every 500 hours grease the joint marked on the Fig. 21.

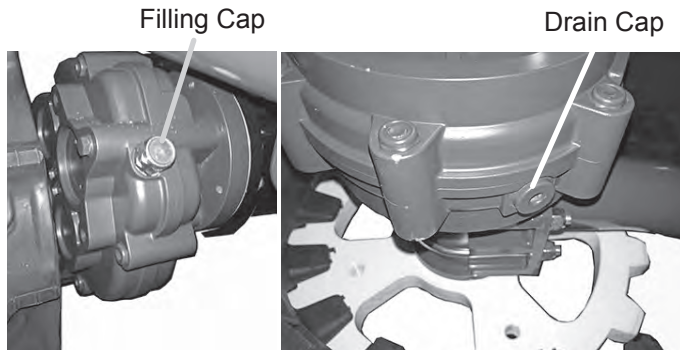

Fig 26

7.2.5 Air filter cleaning (See Cap. 4.2.1)

Clean the air filter and all the engine's air cooling inlet anytime. This action will protect the engine life and assure an higher efficiency and less fuel consumption.

Remove the wing bolt. Draw the element out of the air-cleaner. The filter has 2 elements: one sponge and one paper filter element.

Remove all the grass particle from the sponge and (if necessary) wash the sponge. Dust the paper filter off by patting lightly while holding it with the other hand. When the element does not become clean only by patting, blow dust off the element with compressed air. Apply compressed air from inside to outside of the element.



Fig 27

After cleaning, install the element in reverse order of disassembly.

👉 IMPORTANT

Never hit the element against a hard object like a concrete wall. An element which has already been washed five times or is damaged should be replaced with a new one. Never attempt to start the engine without the aircleaner element. Such operation will cause engine trouble.

7.2.6 PTO Belt adjustment

The belt can change its dimension after few hours of work, therefore it is recommend to adjust the belt tension according to the service schedule in Cap 7.2.1.

To adjust the belt, remove the belt cover. Check the tension applying 5 Kg force on the belt. The bended depth of the belt should not be more than 10 mm.

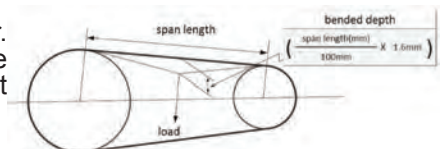

Fig 28

If it is required, adjust the belt tension following these instruction.(Fig.29)

- release the nuts (1) of the engine's slide
- release the locking nuts (2)
- adjust the tension with the screws (3)
- lock the position by the nuts (2)
- fix the position of the engine slide (1)

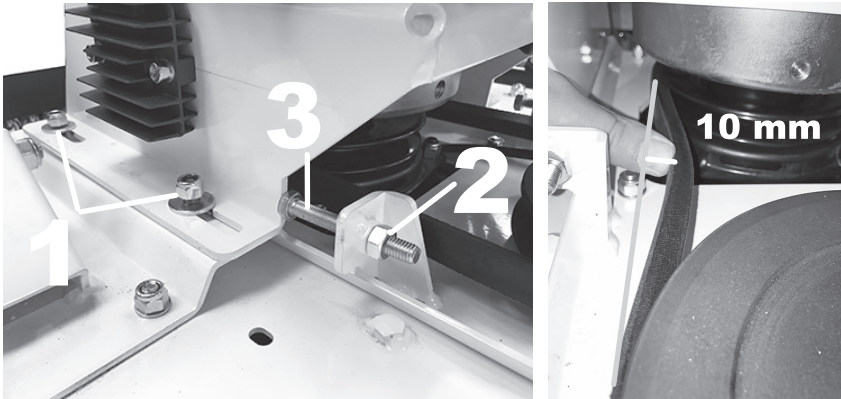

Fig 29

In case it is necessary to replace the Belt, it is necessary to remove the sheet metal cover below the mower deck.(see Fig. 30).

7.2.7 Blade sharpening and replacing

The blade of this mulching machine is turning very fast so that a small damage in one single blade can create an imbalance which turn in a strong noise and vibration. Anytime there is a un-normal noise it is reccomend to verify the condition of the blades.

To check and remove the blade easily, lift the front of the machine by a crane in upright position. Secure the machine by a prop. Unscrew the center bolt to remove the blade support.

- Verify that the blade can rotate easily.
- Sharpen the blade simetrically in order to have the same weight for the two blades.

- Re-asseml the blade support

Lay down the machine carefully on the ground.



Fig 30

7.2.8 Crawler replacement

The Crawlers are wearing parts and their lifetime depend from the enviroment where the machine have been working.

To replace the crawlers it is necessary to lift the machine and positioning 4 props under the mower deck.

To remove the automatic tensor, insert the threaded ROD (provide



inside the electric cabinet) and a 13 key between the crawler chains as shown in the fig.30. Screw the long bolt inside the wheel support.

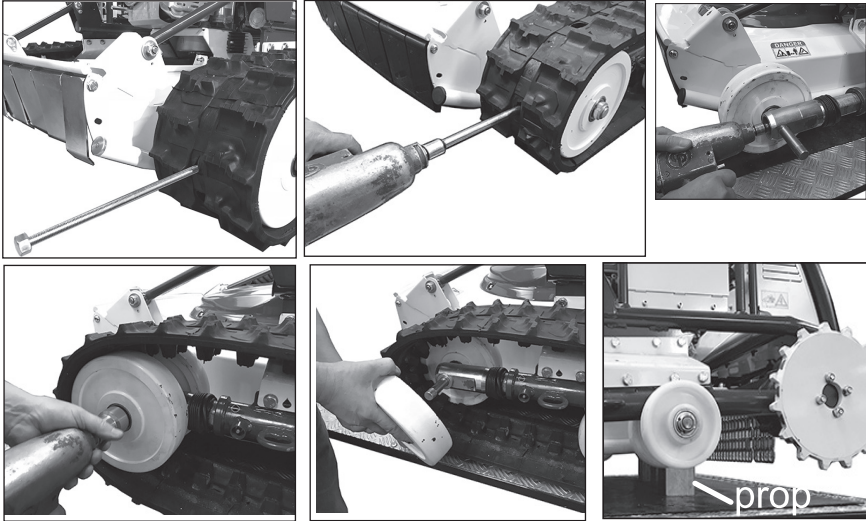

Fig 31

Remove the external wheel as shown in the picture and than the crawler belt is free to be removed.

7.2.9 Battery of the remote control

The radio transmitter is supplied by 2 Li-MH batteries. Even if one battery is enough for one day operation, it is recommend to charge both batteries before starting the work.

To charge the battery a battery charger is supplied with the radio control.

Charger technical data

- Power supply voltage 230V AC
- Power demand 35mA AC/250mA DC (during charge)
- Charging current 650mA
- Battery Ni-MH 3.6V 1.7 A/h
- Max. charging time 3 hours
- Type of charge PVD
- Casing protection degree IP30
- Operating t° (charge) 0°C ÷ +35°C

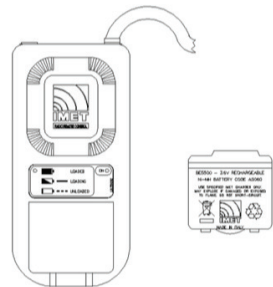

7.3 Notice for disposal



Li-NH Battery

The symbol of the crossed-out waste container on the device means that it must be handled separately from normal waste. The owner is responsible for handing over scrapped equipment to the designated points of collection for the recycling of electric or electronic waste material.

Waste separation contributes to protecting the environment and facilitates recycling.



Pb Battery

Dispose the battery properly because the lead included in a battery is highly polluting.

Exhausted batteries should be disposed of at the specific points of collection, as required by law.



Exhaust oil

Never disperse the waste oil it is highly polluting. few drops can pollute high quantity of water. Gather the waste oil in suitable container and deliver to the recycling service.

WARRANTY CLAIM**SECTION 8 - COMPLAINTS AND WARRANTY**

The basic principle of the guarantee provisions is compliance with and observance of the relevant operating instructions.

Never attempt unauthorized modification of the mower as this could be very hazardous. Damaged or worn parts should be replaced with manufacturer genuine spare parts. Unauthorized parts may cause breakdown of the mower, accidents, and manufacturer warranty to expire.

If in doubt on causes and possible solutions for a certain trouble, please, call our authorized dealer.

This should be absolutely done during the warranty period, since any repair made by non-authorized workshops makes this warranty null and void.

Bear always in mind that the authorized dealer has all special tools, technical specifications and spare parts necessary for properly fixing the machine.

The guarantee can be applied only to devices which are properly used as defined in the first pages of this manual, and are handled according to the operating instructions and the maintenance instructions contained therein. The guarantee refers to the elimination of design defects, material or manufacturing failure that have occurred within the warranty period.

Parts which have become unusable as a result of improper repair work or which are subject to natural wear and tear (see instructions in the operating instructions) are excluded from the guarantee.

The warranty will be void if the device is repaired outside an authorized workshop if it has been resold if no original spare parts are used, and if unauthorized changes have been made to the device.

In the case of justified warranty claims, the Manufacturer grants a claim for free replacement, as well as removal and installation of the defective parts. Without prejudice to the statutory warranty claims, further guarantees can not be claimed. Work under the guarantee does not trigger a new beginning of the guarantee period.

8.1 DEFINITION

For guarantee it intends the substitution of any machine's component for whom is ascertained the defect, after a test executed by our Technical Department. The transport cost are expressly excluded from the guarantee and are on client's charge. Are also excluded trouble caused by carelessness and incompetence as well as bearing to external causes (atmospherics agent, fire); last but not list are out the elements which are in contact with the ground (blades, knives, bumper, tyres). The guarantee decays if on the machine there are accessories and spare parts not furnished or authorized by the manufacturer.

8.2 WARRANTY STARTS: The warranty period starts on the date the vehicle is delivered to the first retail purchaser or put in service by an authorized Dealer.

8.3 DURATION

The period of warranty is:

- 24 months for private utilization of the machine;
- 12 months for commercial - municipality or renting operation.

In this period value the guarantee terms as specified on paragraph 8.1.

8.4 ENGINE WARRANTY

The conditions and the terms of warranty are those conceded by the engine's manufacturer; the on guarantee assistance will have to be strictly executed in the Authorized service centres. For further information see the engine manual delivered with the machine.

8.5 CLAIM FORM

It is always necessary indicate always:

- 1- Machine's type
- 2- Machine serial number
- 3- Parts name and code number
- 4- Quantity required
- 5- Circumstances of failure
- 6- Working time

We recommend to write here below these data for future communication.

XRot



BARBIERI SRL
P.zza Don Luigi STURZO, 15
00144, Roma - ITALY
Phone: (0444) 885-722
Fax: (0444) 885-482