

# User Manual and Spare Parts Catalogue



## TP 175 ZE MOBILE

DESIGNED

+

MANUFACTURED

↓

DENMARK

RELIABLE  
CHIPPING



## 1 Introduction

Congratulations on your new TP wood chipper.

Linddana produces TP wood chippers of the finest quality by using the most modern production technologies, such as laser cutting, CNC - technology and robot technology in bright and open production facilities.

For safety reasons and in order to get the maximum benefit from your wood chipper, it is important that you read the user manual before use.

Originally written in Danish, the user manual provides an explanation of safety, use and maintenance, to ensure working with the wood chipper will be safe and profitable.

Linddana A/S



Hans Anker Holm, CEO

Your local dealer is always at the ready to provide spare parts, advice and guidance.

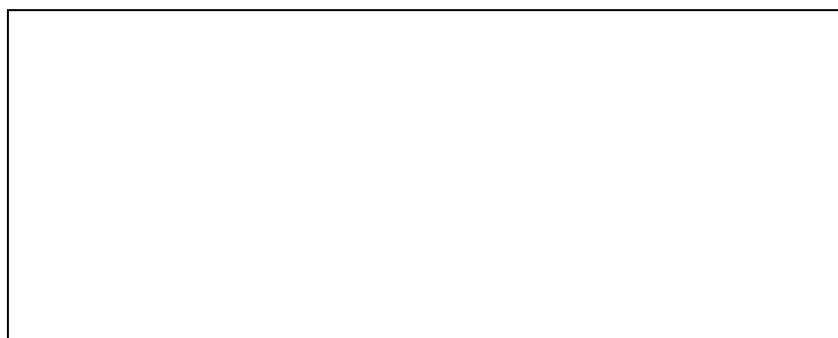

Dealer stamp

**Applies to Denmark (for all other countries, contact the local TP dealer):**

Linddana provides a blade sharpening service, so your blades can be sharpened and sent back on the same day as they are received (for more details tel.: 76904045)

To keep your wood chipper in top condition and prolong its lifetime, Linddana offers a service contract, under which the wood chipper will be checked once a year by our technician, ideally in collaboration with the user. In addition to a technical check, the user will be given advice on the use and maintenance of the wood chipper.

## 2 EU DECLARATION OF CONFORMITY



**Manufacturer:**

LINDDANA A/S, Ølholm Bygade 70, Ølholm, 7160 Tørring, Denmark  
hereby declares that

**Wood chipper:**

---

and accompanying extra equipment is in conformity with the requirements of the Machinery Directive (Directive 2006/42/EC) and with the national legislation which translates this directive;

furthermore, is in conformity with the following EC Directives:  
2000/14/EC

Furthermore, it is stated that  
EN 13525 (harmonised standard) has been applied.

Title: CEO

Name: Hans Anker Holm

A handwritten signature in black ink, appearing to read 'Hans Anker Holm', written in a cursive style.

Ølholm, 4. June 2020

### 3 Contents

<b>1</b>	<b>Indroduktion .....</b>	<b>2</b>
<b>2</b>	<b>EU-Overensstemmelseserklæring .....</b>	<b>3</b>
<b>3</b>	<b>Indholdsfortegnelse.....</b>	<b>4</b>
<b>4</b>	<b>Anvendelse og sikkerhed .....</b>	<b>6</b>
4.1	Påbud og Advarsler .....	6
4.2	Anvendte piktogrammer.....	16
<b>5</b>	<b>Støjniveau .....</b>	<b>18</b>
5.1	Miljøanvisninger.....	18
<b>6</b>	<b>Håndtering .....</b>	<b>19</b>
<b>7</b>	<b>Før opstart.....</b>	<b>20</b>
7.1	Kontrol af flishugger før opstart .....	20
7.2	Åbning og lukning af rotorhus.....	21
7.3	Åbning og lukning af valsekonsol .....	25
<b>8</b>	<b>Betjening af flishuggeren.....</b>	<b>27</b>
8.1	Sikkerhedsbøjle .....	27
8.2	Indstilling af omdrejningstallet for indtræksvalser .....	28
8.3	Fast udkasterrør (afhængig af modellen) .....	29
8.4	TP VARIO SPOUT (afhængig af modellen).....	29
8.5	Opstart og igangsætning af flishugger .....	32
8.6	Til- og frakoblingsanvisning.....	33
8.7	Klapbar tragt .....	34
<b>9</b>	<b>Batteriovervågning .....</b>	<b>35</b>
<b>10</b>	<b>Opladning .....</b>	<b>36</b>
<b>11</b>	<b>Instruktion for omdrejningsvagt TP PILOT .....</b>	<b>37</b>
11.1	Overordnet betjening .....	37
11.2	Programmering .....	40
11.3	Monteringsdiagram .....	43
11.4	Tekniske data .....	43
<b>12</b>	<b>Vedligeholdelse.....</b>	<b>43</b>
12.1	Vedligeholdelsesskema for flishugger .....	44
12.2	Hydraulikolieskema.....	44
12.3	Kontrol af hydraulikolieniveau .....	45
12.5	Smøring .....	47
12.6	Hydraulikolie udskiftning .....	48
12.7	Knive.....	51
12.8	Modstål .....	54
12.9	Afstrygere og afskrabere.....	56
12.10	Pumpetransmission .....	57
12.11	Batteri hensyn .....	58
<b>13</b>	<b>Hydrauliksystem.....</b>	<b>58</b>
13.1	Udskiftning af hydraulikslanger .....	58
13.2	Hydraulikdiagram TP 175 MOBILE ZE .....	58

---

<b>14</b>	<b>Eldiagram TP 175 MOBILE ZE .....</b>	<b>59</b>
14.1	Diagram trailer .....	60
<b>16</b>	<b>Fejlfinding .....</b>	<b>61</b>
<b>17</b>	<b>Garantibestemmelser flishugger .....</b>	<b>62</b>
<b>18</b>	<b>Tekniske data flishugger .....</b>	<b>63</b>
<b>19</b>	<b>Ekstra udstyr .....</b>	<b>64</b>
19.1	TP CHIP KIT .....	64
19.2	TP TOOLKIT .....	67
19.3	TP SPARE WHEEL .....	68
<b>20</b>	<b>Reservedelskatalog .....</b>	<b>70</b>





## 4 Use and safety

This TP wood chipper is specially designed as a stationary wood chipper, which chips wood in the form of branches, bushes and waste wood from windbreaks, parks, roadside trees, etc.

Any modification to the design of the machine is strictly prohibited. In the event that modifications are made, Linddana A/S disclaims all liability.

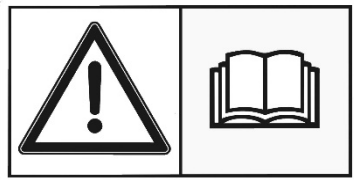
### 4.1 Mandatory Instructions and Warnings

#### 4.1.1 Before use

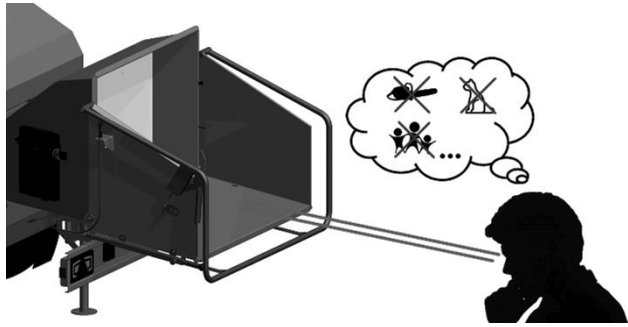
	 <p><b>ALWAYS</b> read the user manual before using the wood chipper. Remember to store the user manual in the manual box.</p>
	 <p><b>ALWAYS</b> wear ear protectors, safety goggles, close fitting safety clothing and safety shoes.</p>
	 <p><b>ALWAYS</b> ensure that the funnel is free of people, animals and other foreign bodies before starting the wood chipper.</p>



**ALWAYS** ensure that all of the guards are securely closed/fitted before starting the wood chipper.



**ALWAYS** ensure that the wood chipper is safely parked before starting the wood chipper.

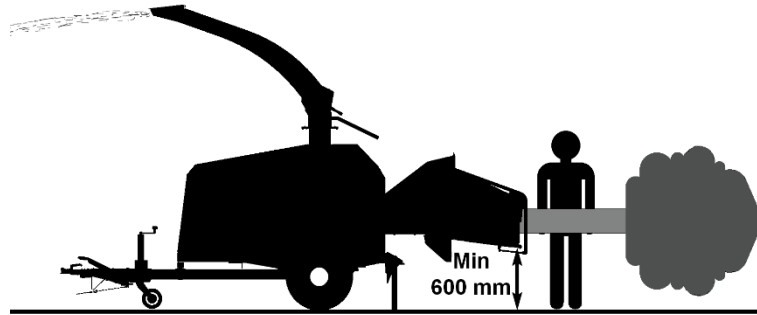



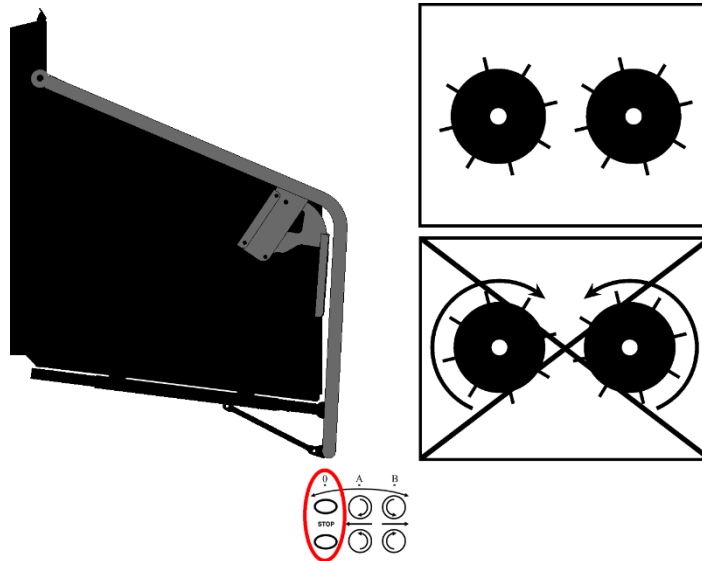



**ALWAYS** ensure that there is more than 600 mm of clearance between the ground and the wood chipper's lowest funnel edge and that it stands on a level surface.



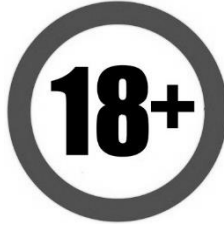



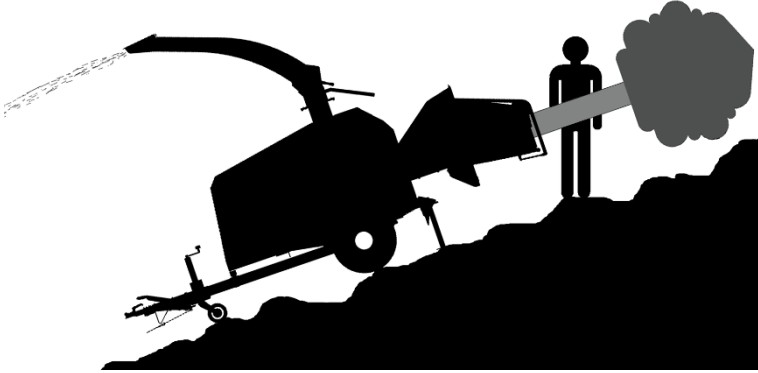

**ALWAYS** ensure that all of the safety devices function correctly before starting the wood chipper. This applies in particular to the safety bar's STOP function.

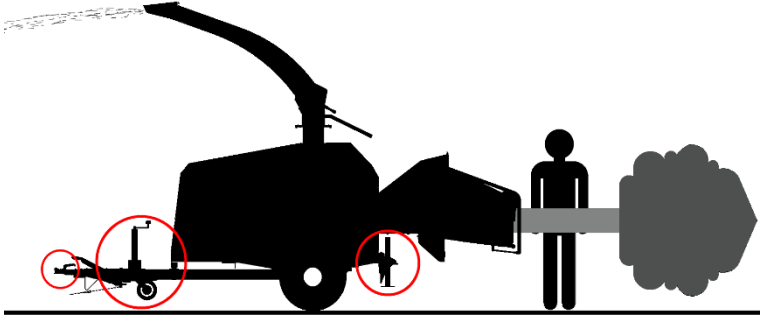

**ALWAYS** check the ground conditions around the wood chipper. Falling down in the vicinity of the wood chipper can be hazardous.

	 <p><b>NEVER</b> allow anyone under 18 years of age to operate the wood chipper (however, anyone who is 16 years old and over may do so under the supervision of an adult).</p>
	 <p><b>NEVER</b> operate the wood chipper if under the influence of alcohol or narcotic substances.</p>
	 <p><b>NEVER</b> operate the wood chipper on uneven or inclined surfaces.</p>
	<p><b>NEVER</b> start the wood chipper without the ejector spout fitted.</p>
	<p><b>NEVER</b> use the wood chipper in enclosed or poorly ventilated spaces, because of the danger of carbon monoxide poisoning.</p>

	 <p><b>NEVER</b> point the ejector spout in the same direction as people or at an area that people move around in. A safe distance of 20 m must be maintained in the direction of where the woodchips are ejected.</p>
	 <p><b>NEVER</b> operate or park the wood chipper without support from the jack and support leg or from the vehicle's trailer hitch.</p>
	<p><b>NEVER</b> use the wood chipper with material that is not wood.</p>
	<p><b>NEVER</b> use the wood chipper to push trees, stumps, etc.</p>
	<p><b>NEVER</b> transport equipment inside the funnel, such as forest chains, axes, chainsaws, etc.</p>

#### 4.1.2 During operation



**ALWAYS** push the safety bar into the STOP position if a dangerous situation arises (see chapter 8).



**ALWAYS** keep body parts away from the funnel and the wood chipper's other moving parts.



**ALWAYS** stand at the side of the funnel when the wood chipper is chipping trees with side branches.



**ALWAYS** push logs in from the rear of the log.



**ALWAYS** use a rod to push short pieces of tree into the rollers.

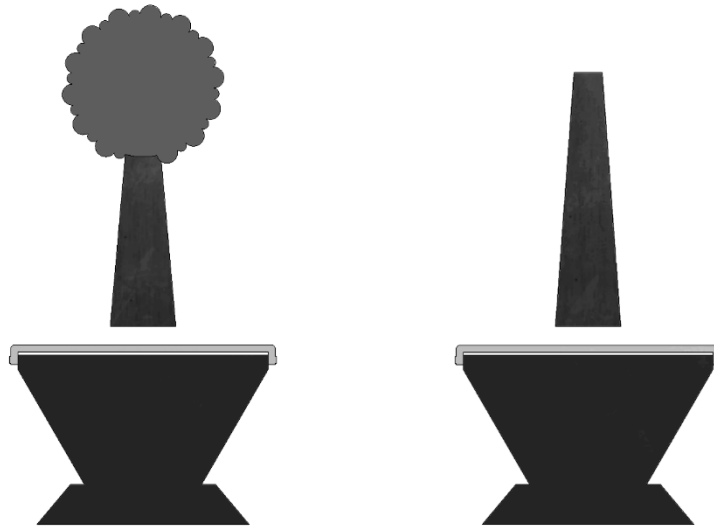

**ALWAYS** feed the wood chipper with the thick end of the log first.

**ALWAYS** feed the wood chipper so that the tree crown points away from the funnel.

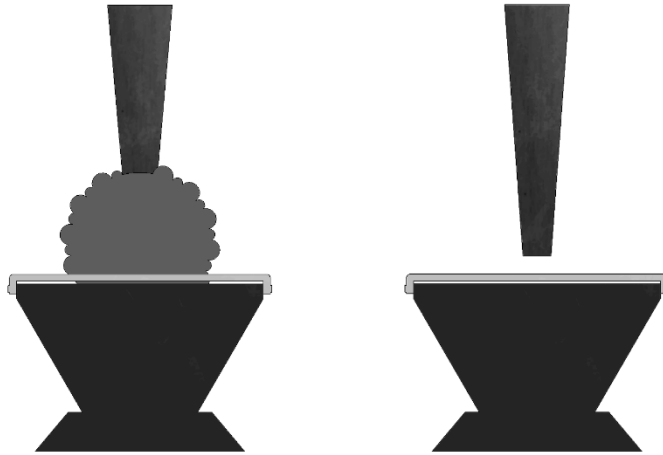

**NEVER** feed the tree crown into the wood chipper first.

**NEVER** feed the wood chipper with the thin end of the log first.



**NEVER** attempt to remove any trapped material from between the feed rollers before the wood chipper has stopped and the key has been removed and the roller console has been opened, as described in chapter 7.3.









**NEVER** reach into the funnel to push wood into the rollers.



**NEVER** open or remove the guard while the wood chipper is operating.

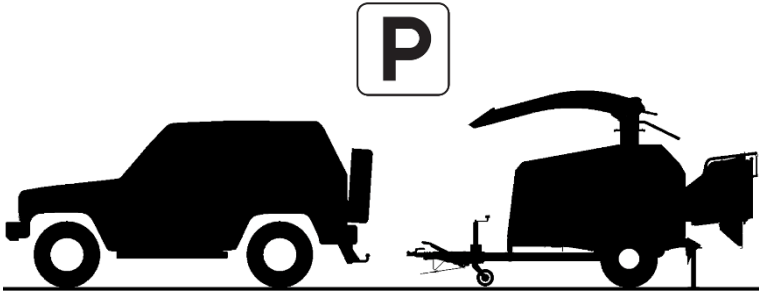

### 4.1.3 Transport and parking



	<p><b>ALWAYS</b> comply with local public authority regulations when transporting the wood chipper on public roads.</p>
	<p><b>ALWAYS</b> keep the ejector spout completely down in the bottom during transport. Remember to ensure that the transport lock is engaged.</p>
	<p><b>ALWAYS</b> keep the ejector spout within the width of the machine during transport. Remember to ensure that the ejector spout is securely fastened.</p>
	<p><b>ALWAYS</b> place the foldable funnel in the transport position during transport (the funnel must be folded up and locked using the pin).</p>
	<p><b>ALWAYS</b> ensure that all of the wood chipper lights work correctly before transporting the wood chipper.</p>
	<div data-bbox="497 1128 1259 1420"></div> <p><b>ALWAYS</b> park the wood chipper on a level surface.</p>

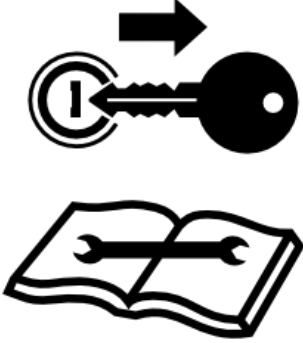

**NEVER** park the wood chipper on inclined or uneven surfaces.

#### 4.1.4 Service and repairs

	 <p><b>ALWAYS</b> remove the key from the ignition and ensure that the disc has stopped moving before carrying out service or repairs.</p>
	<p><b>ALWAYS</b> ensure, after service or repair, that all of wood chipper bolts are fitted and tightened securely and that all of the safety devices are fitted and function properly.</p>
	<p><b>ALWAYS</b> ensure that the knives, counterknives and rollers are kept sharp. This results in smoother in-feed, higher woodchip quality and less fuel consumption.</p>

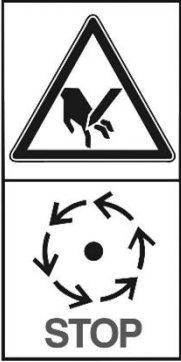
	<p><b>NEVER</b> carry out service or repairs on the wood chipper while the key is in the ignition lock.</p>
	 <p><b>NEVER</b> remove or open the guards before the disc has stopped moving.</p>

## 4.2 Pictograms used

 <p><b>Warning:</b> Ejected objects!</p> <p><b>Warning:</b> Safety distance 20m!</p>	 <p><b>Warning:</b> Rotating blades!</p> <p><b>Warning:</b> Wait for disc to stop</p>	 <p><b>Warning:</b> Risk of being pulled in!</p> <p><b>Warning:</b> Rotating rollers</p>
 <p><b>Warning:</b> Risk of being pulled in!</p> <p><b>Warning:</b> Rotating belts</p>  <p><b>Warning:</b> Hot surface</p>	 <p><b>Warning:</b> Risk of limb amputation!</p> <p><b>Warning:</b> Risk of being pulled in!</p> <p><b>Warning:</b> Do not step on the funnel</p> <p><b>Warning:</b> Do not touch the funnel!</p> <p><b>Warning:</b> Do not crawl into the funnel!</p>	 <p><b>Warning:</b> Read the instruction manual before use</p>  <p><b>Warning:</b> Remove the ignition key and read the user manual before service or repairs.</p>

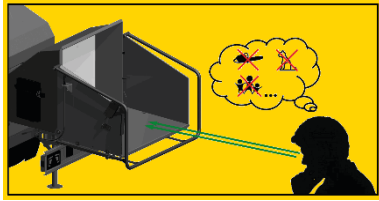

**Warning:** Ensure that the funnel is free of people, animals and other foreign bodies.

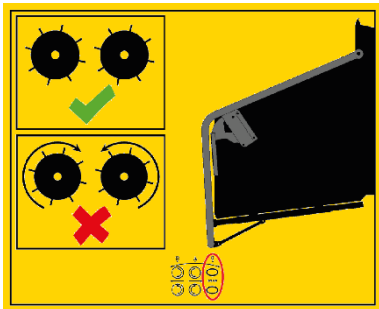

**Warning:** Ensure that the safety bar works.

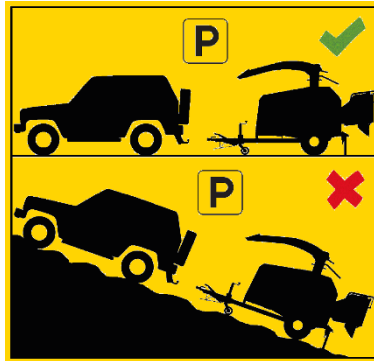

**Warning:** Do not park on uneven or inclined surfaces.

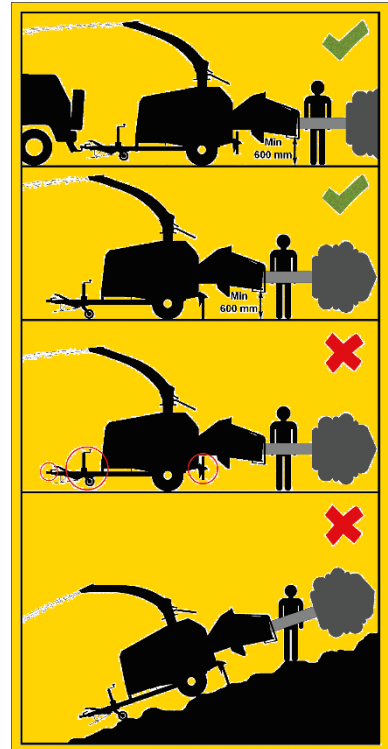

**Warning:** Do not operate the wood chipper without support from the jack and support leg or from the vehicle's trailer hitch.

**Warning:** Do not operate the wood chipper on uneven or inclined surfaces.



**Warning:** Scalding hazard.



Ear and eye protection mandatory.



Lifting point for crane.

For safety information and pictograms relating to the engine, see the engine manual.

## 5 Noise level

The sound output level and the sound pressure level for every wood chipper has been measured during use with the disc at nominal rpm, powered by the engine. For specific rpm values and engine types (see technical data wood chipper in chapter 19).

The measurements have been conducted in accordance with testing provisions

Directive 2000/14/EC, 3 July 2000

EN ISO 3744, 1995

ISO 11201, 1995

ISO 4871, 19 March 1997

EN 13525, 17 February 2005

The guaranteed sound output level which must be stated by the manufacturer in accordance with Directive 2000/14/EC is as follows:

**TP 175 MOBILE: 124 dB (A) relative to 1 pW**

The wood chipper's sound pressure level at the operator's position is measured in accordance with ISO 11201 as follows:

**TP 175 MOBILE: 103 dB (A)**

The values stated above are subject to the common uncertainty of the measuring method and the estimated variation in a product series for the type of machine. Detailed information about the measurements and results and estimation of uncertainty are found in a detailed report which can be supplied on request.

As a result of the actual sound levels, the wearing of ear protectors is mandatory when using the wood chipper.

### 5.1 Environmental instructions

When changing hydraulic oil or engine oil, oil and used oil filters and air filters must be disposed of responsibly at an approved waste disposal station.

Oil spillage must be avoided as far as possible. Should oil spillage occur, the spilled oil must be cleaned up and disposed of at an approved waste disposal station.

Worn out parts must be disposed of for recycling.

When the wood chipper is worn out, it must be disposed of responsibly. Hydraulic oil and engine oil must be drained and disposed of along with oil filters and air filters at an approved waste disposal station.

The rest of the wood chipper must be disposed of at an approved recycling centre.

## 6 Handling

### Lifting point



The wood chipper is equipped with a lifting point, which must be used whenever it is lifted by a crane or other lifting gear (with hooks) (see illustration above). (see illustration above).

## 7 Before start-up

### 7.1 Check the wood chipper before start-up.

#### Chipping unit

1. Open the disc housing, as described later in this chapter.
2. Ensure that the wood chipper is free of any foreign bodies by turning the disc a few times by hand.  
a few times by hand. Remove any foreign bodies.
3. Check that the blades run clear of the counterblades.
4. Ensure that the distance between the blades and counterblades is correct. The distance is stated in chapter 13.
5. Close the disc housing, as described later in this chapter.
6. Ensure that all of the bolts, nuts and screws are tightened securely.
7. Remember to lubricate all of the lubrication points (see maintenance schedule in chapter 13).

## 7.2 Opening and closing of disc housing

The wood chipper's key must be removed from the ignition when the disc housing is opened and may only be re-inserted after the disc housing has been closed again!

### Opening the disc housing

1. Check that the wood chipper's key is removed from the ignition and the disc has stopped moving.
2. Lower the ejector spout all the way to the bottom (if the model is equipped with TP VARIO SPOUT).  
(See Operating the wood chipper in chapter 8).
3. Turn the ejector spout so that it faces the opposite direction of the disc housing (see illustration below).  
(See also Operating the wood chipper in chapter 8).
4. Open the bonnet. The bonnet is locked with an external catch on each side.

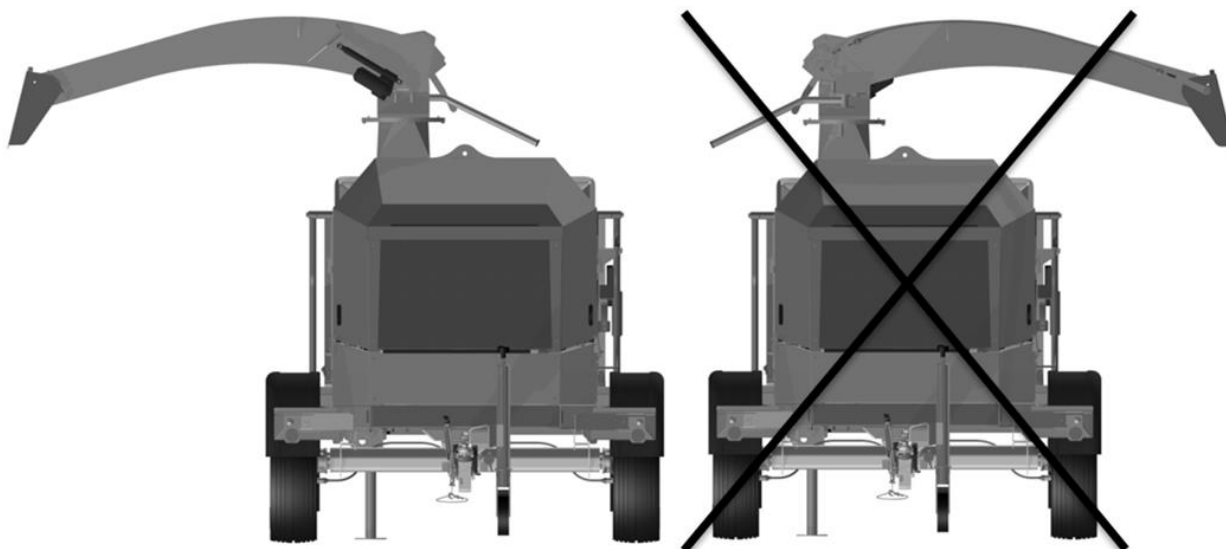

5. Loosen the M12 bolts (two or three bolts depending on the model), which secure the disc housing top and bottom parts together (see the illustration below). (See illustration below).

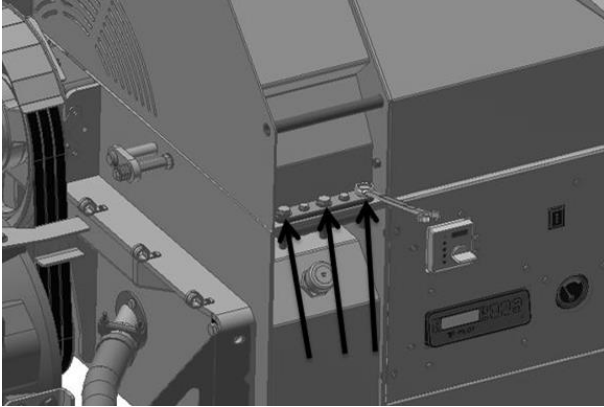

6. Open the top section of the disc housing until it meets the stop. (See illustration below).

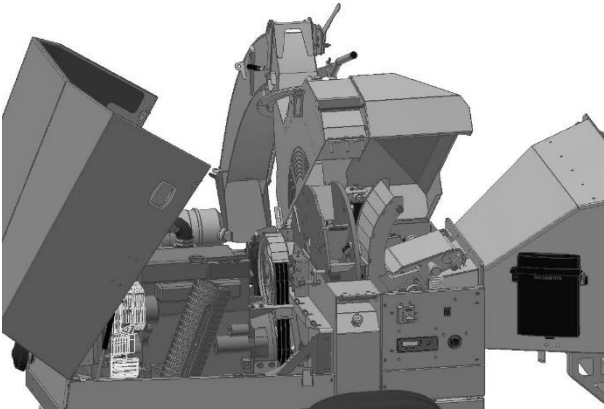

7. Turn the disc until the yellow disc lock can go into one of the holes on the disc. The disc is now locked.  
Keep fingers away from the knives when the disc is being turned.

As far as possible, the disc must always be locked when the disc housing is open. (See illustration below).

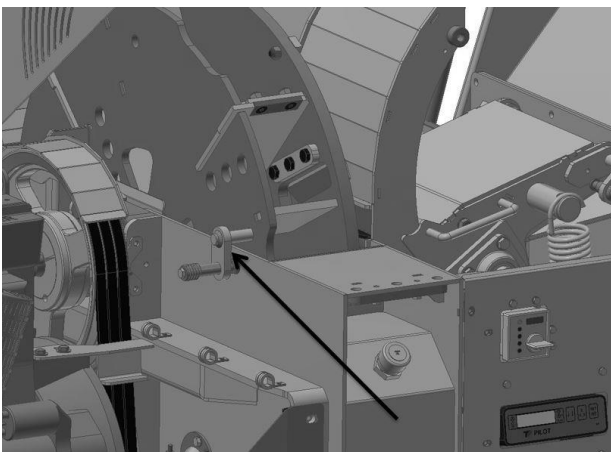

## Closing the disc housing

1. Free the yellow disc lock from the disc and turn the disc a few times to make sure that there are no objects in the disc housing.  
Keep fingers away from the knives when the disc is being turned  
(See illustration below).



2. Close the top part of the disc housing (See illustration below).

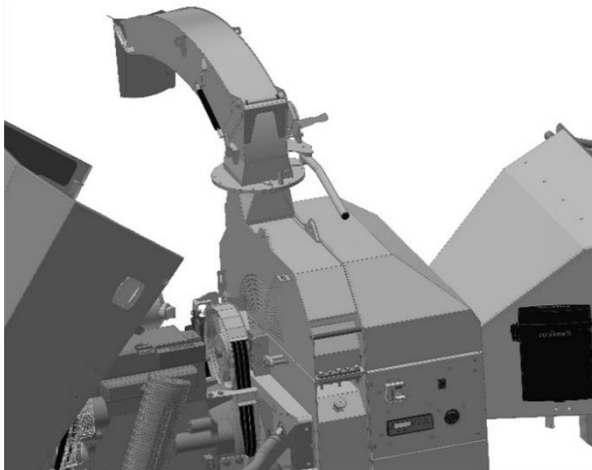

3. Tighten the M12 bolts (two or three depending on the model), so that the top and bottom of the disc housing is tightened together securely  
(See illustration below).

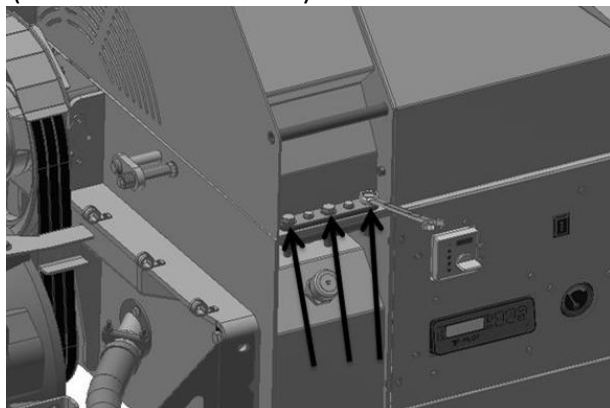

4. Close the bonnet and lock it using the external catches. Turn the ejector spout into position and lock securely (See Operating the wood chipper in chapter 8).

## 7.3 Opening and closing the roller console

### Opening the roller console

The roller console's retention force is created by springs (one or two, depending on the model). When adjusting and replacing the counterknife, and if necessary, when opening the roller console to remove any foreign bodies in the in-feed, the springs must be removed (See illustration below).

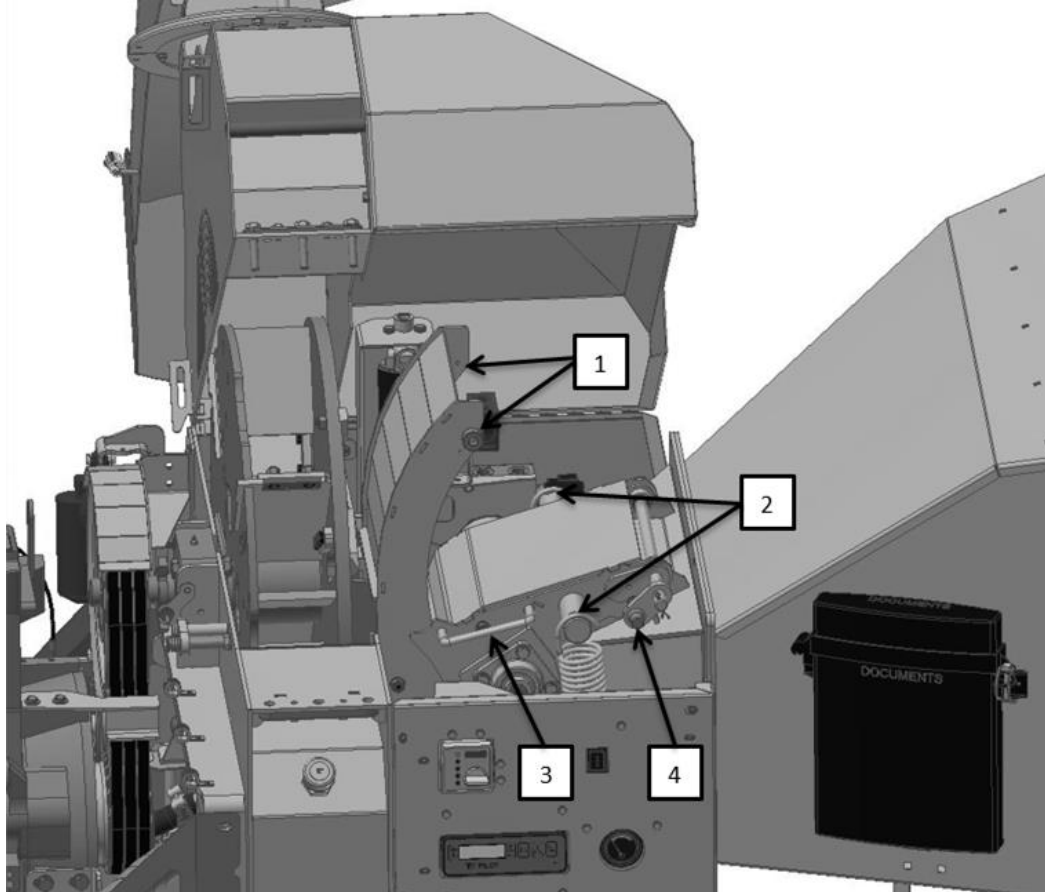

1. Open the disc housing, as described earlier in this chapter.
2. Remove the stop bushing (1), which limits the roller console's movement range.
3. Using multigrip pliers or similar, lift the springs (2) from the roller console (keep fingers away from the springs when lifting the springs from the roller console).
4. Hold the handle (3) and lift the roller console up, until the roller console meets the opening stop.
5. Push the locking pawl (4) into the lock on the side of the roller console.

The roller console is now open and secured from falling down.

## Closing the roller console

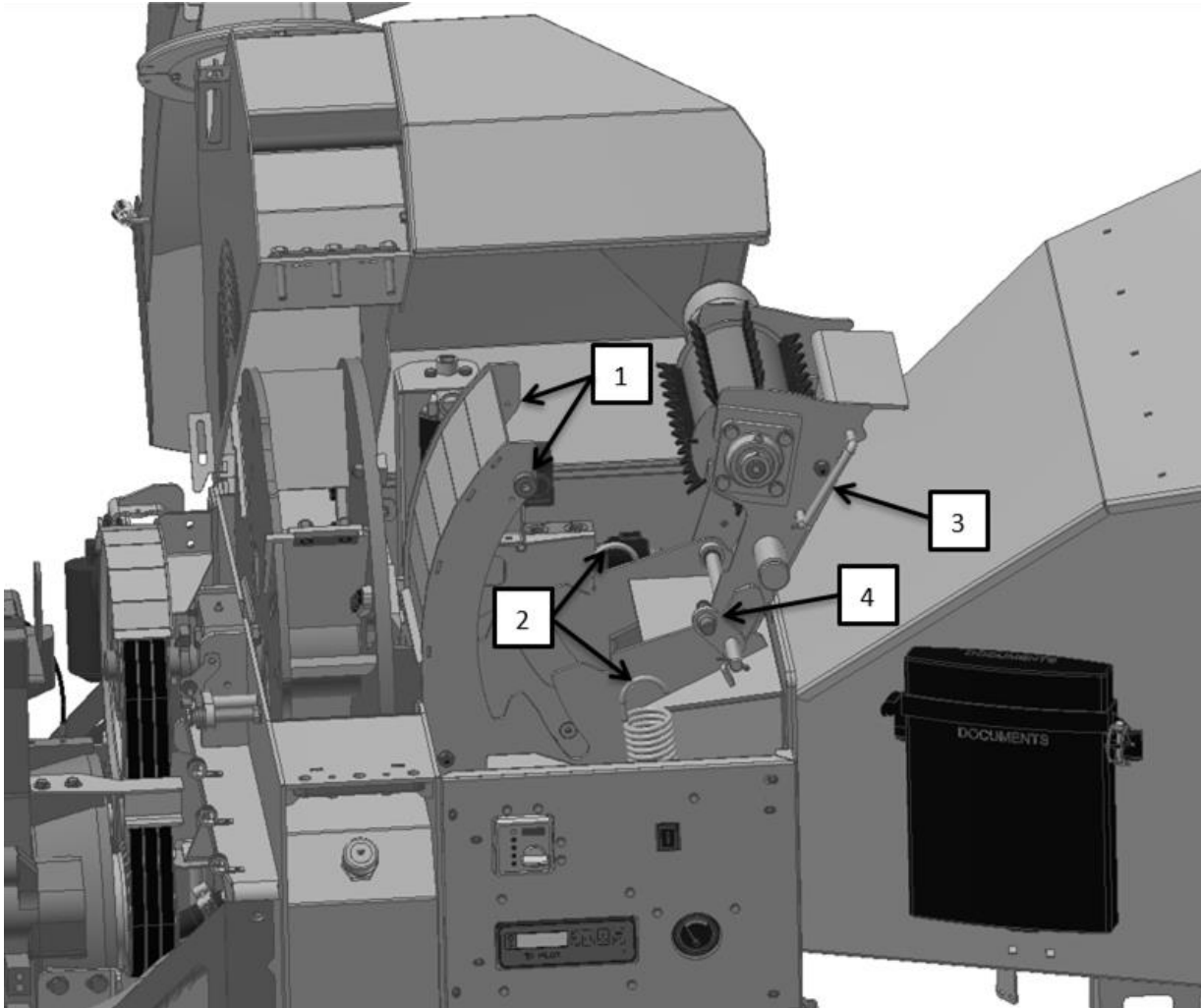

1. Hold the handle (3) and pull out the locking pawl (4).
2. Lower the roller console back into position.
3. Lift the springs (2) back onto the roller console using multigrip pliers or similar.
4. Mount the stop bushings (1).
5. Close the disc housing, as described earlier in this chapter.

## 8 Operating the wood chipper

### 8.1 Safety bar

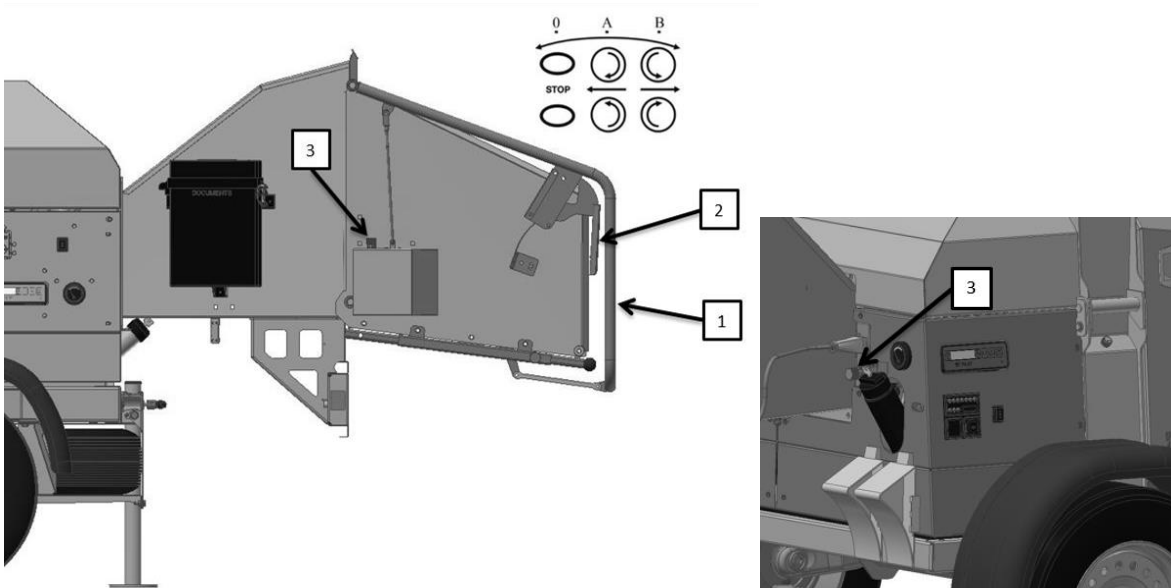

The wood chipper is equipped with two hydraulic rollers, which are controlled by a safety bar (1) with a reset handle (2) and a roller speed controller (3) (see illustrations above). (see illustrations above).

(Whether the roller speed controller is fitted depends on the model).

#### **Position A**

The rollers rotate inwards and the material is drawn into the wood chipper.

#### **Position B**

The rollers rotate outwards and the material is pushed out of the wood chipper.

#### **Position 0**

The rollers are stopped.

When the safety bar has been pushed into position 0, the bar is locked. This is to ensure that the rollers are not unintentionally re-started.

To subsequently move the safety bar into position A or B, activate the reset handle.

During start-up, the safety bar must always be in position 0.

**IN CASE OF POTENTIAL HAZARDS: PUSH THE SAFETY BAR INTO THE STOP POSITION (position 0).**

## 8.2 Setting the rpm for the feed rollers

(Only applies to models shown in the table below).

By turning the roller speed controller, the in-feed of the wood chipper is regulated. Never operate too quickly with the rollers because the wood will act like a brake if the pressure on the disc is too great, which will cause overheating, overloading and increase fuel consumption. Branches may become wrapped around the rollers if the roller rpm is too high.

The table shown below provides the recommended rpm of the feed rollers with the respective desired woodchip length.

<b>Woodchip length:</b>		<b>4 mm</b>	<b>6 mm</b>	<b>8 mm</b>	<b>10 mm</b>	<b>12 mm</b>
<b>Model:</b>	<b>Disc rpm</b>	<b>Roller rpm</b>	<b>Roller rpm</b>	<b>Roller rpm</b>	<b>Roller rpm</b>	<b>Roller rpm</b>
<b>TP 175 ZE MOBILE</b>	1450	13	20	26	34	41

### 8.3 fixed ejector spout (dependent on the model)

The wood chipper may be equipped with a fixed ejector spout. To turn the ejector spout, use the handle (1) once the sliding bolt (2) is loosened. To re-secure the ejector spout, lock the sliding bolt (2) in the desired position. The handle (1) can be turned in the opposite direction for operating from the front of the ejector spout. To do this, loosen the sliding bolt (3) and turn the handle 180 degrees until the sliding bolt (3) once again can lock the handle (See illustration below). The tilting spout is operated using the handle (4), which tilts away from the front position plate. Next, move the handle to the desired position and again release, the handle subsequently locks the tilting spout in the desired ejection position.

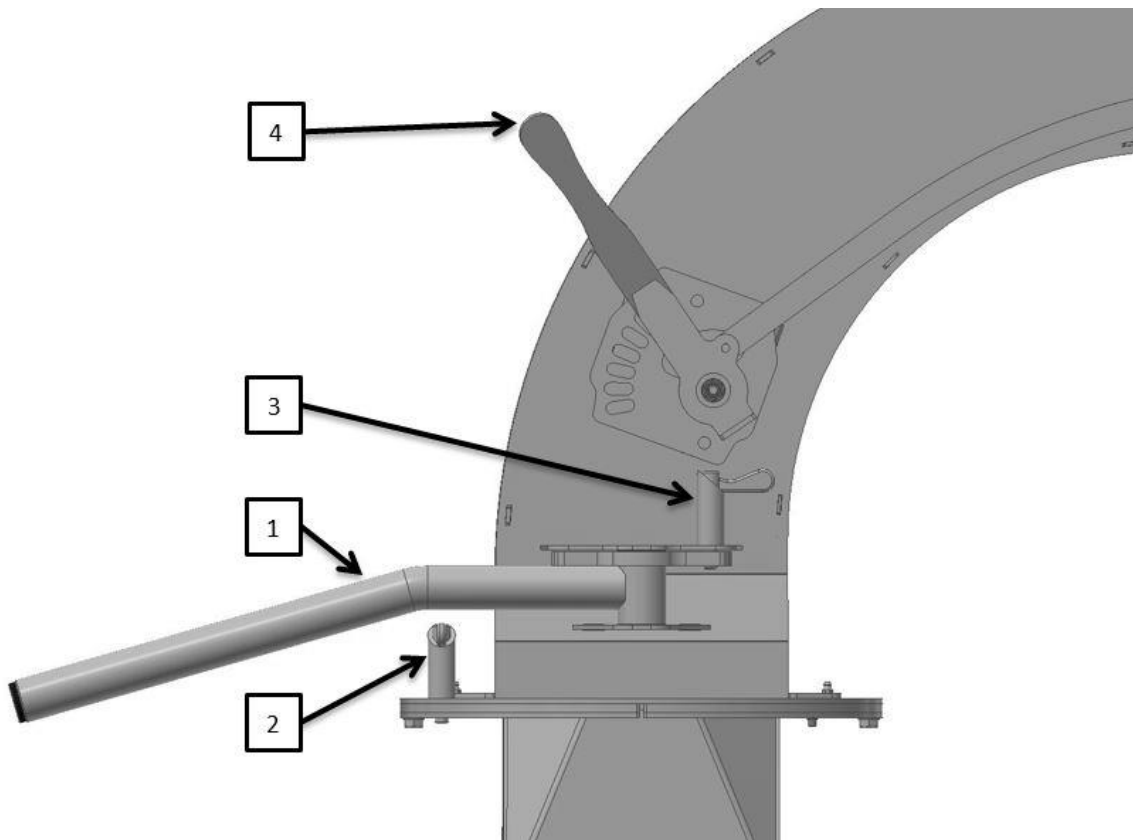

NB: When operating the ejector spout, there must not be any people inside the ejection area. During transport, the ejector spout must always be within the machine's width and the sliding bolt (2) must be locked.

### 8.4 TP VARIO SPOUT (dependent on the model)

The wood chipper can be equipped with TP VARIO SPOUT, which is a height-adjustable ejector spout, which has different operating positions (five or six, dependent on the model) and one transport position. To adjust the ejector spout height manually, use the handle (7), once the sliding bolt (1) and sliding bolt (2) are loosened. To re-secure the ejector spout in the desired position, lock the sliding bolt (1). The wood chipper may only be operated when the ejector spout is within the operating positions at the sliding bolt (1). (See illustration below).

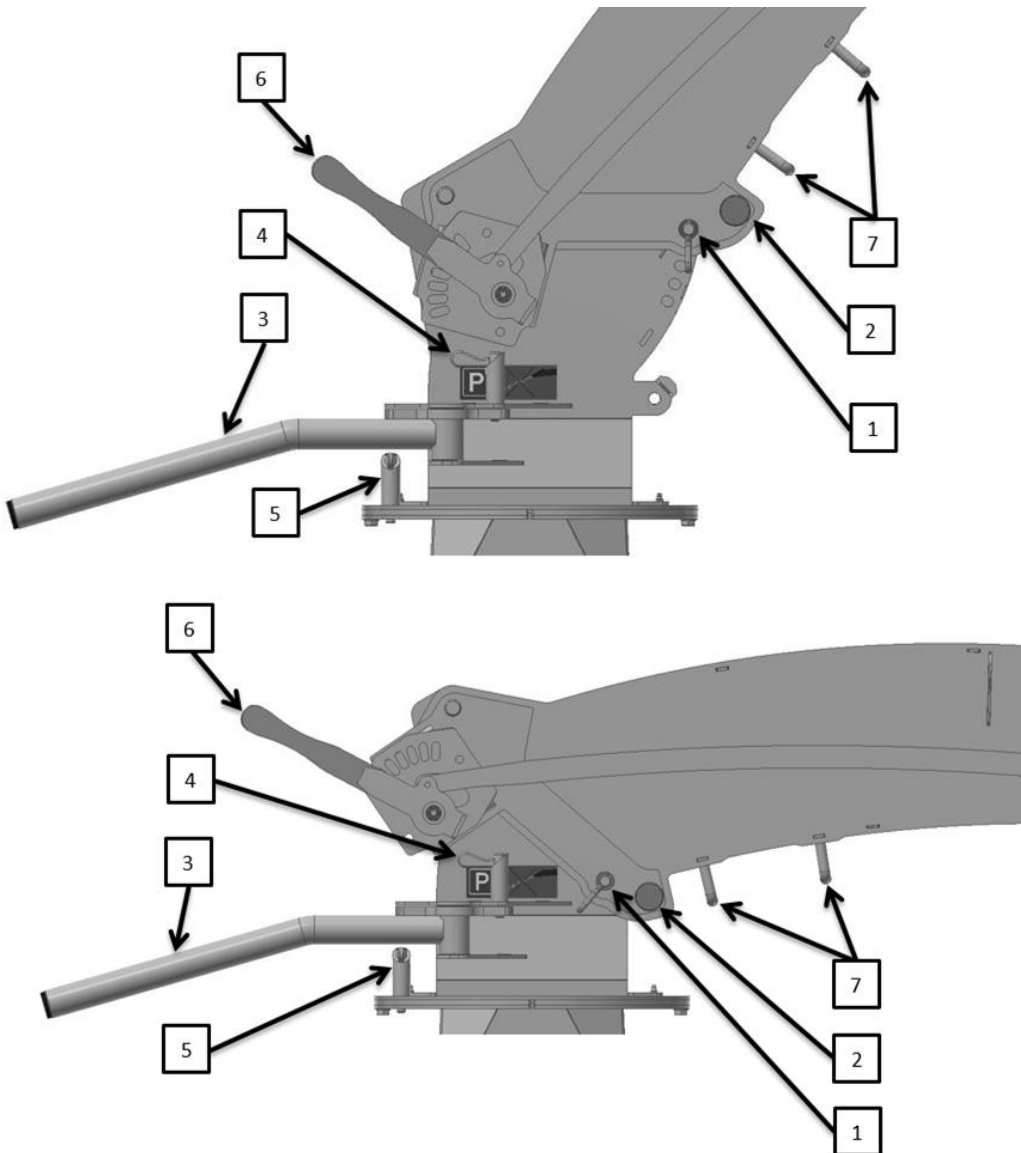

NB: When operating the TP VARIO SPOUT, there must not be any people inside the ejection area. At the same time, exercise caution when the TP VARIO SPOUT is lowered down into the transport position, because the end of the ejector spout reaches head height and this is a potential hazard.

To turn the TP VARIO SPOUT use the handles (3) once the sliding bolt (5) is loosened. To re-secure the TP VARIO SPOUT, lock the sliding bolt (5) in the desired position. The handle (3) can be turned in the opposite direction for operating from the front of the TP VARIO SPOUT. To do this, loosen the sliding bolt (4) and turn the handle 180 degrees until the sliding bolt (4) once again can lock the handle.

The tilting spout is operated using the handle (6), which tilts away from the front position plate. Next, move the handle to the desired position and again release, the handle subsequently locks the tilting spout in the desired ejection position.

When the wood chipper shall be parked or transported, completely lower the ejector spout manually using the handle (7) when the sliding bolt (1) is loosened. Check subsequently and before

---

transportation on public roads, that the sliding bolt (2) is locked and engaged (see illustration above).

During transport, the TP VARIO SPOUT must always be within the machine's width and the sliding bolt (5) must be locked.

## 8.5 Start-up and commissioning the wood chipper

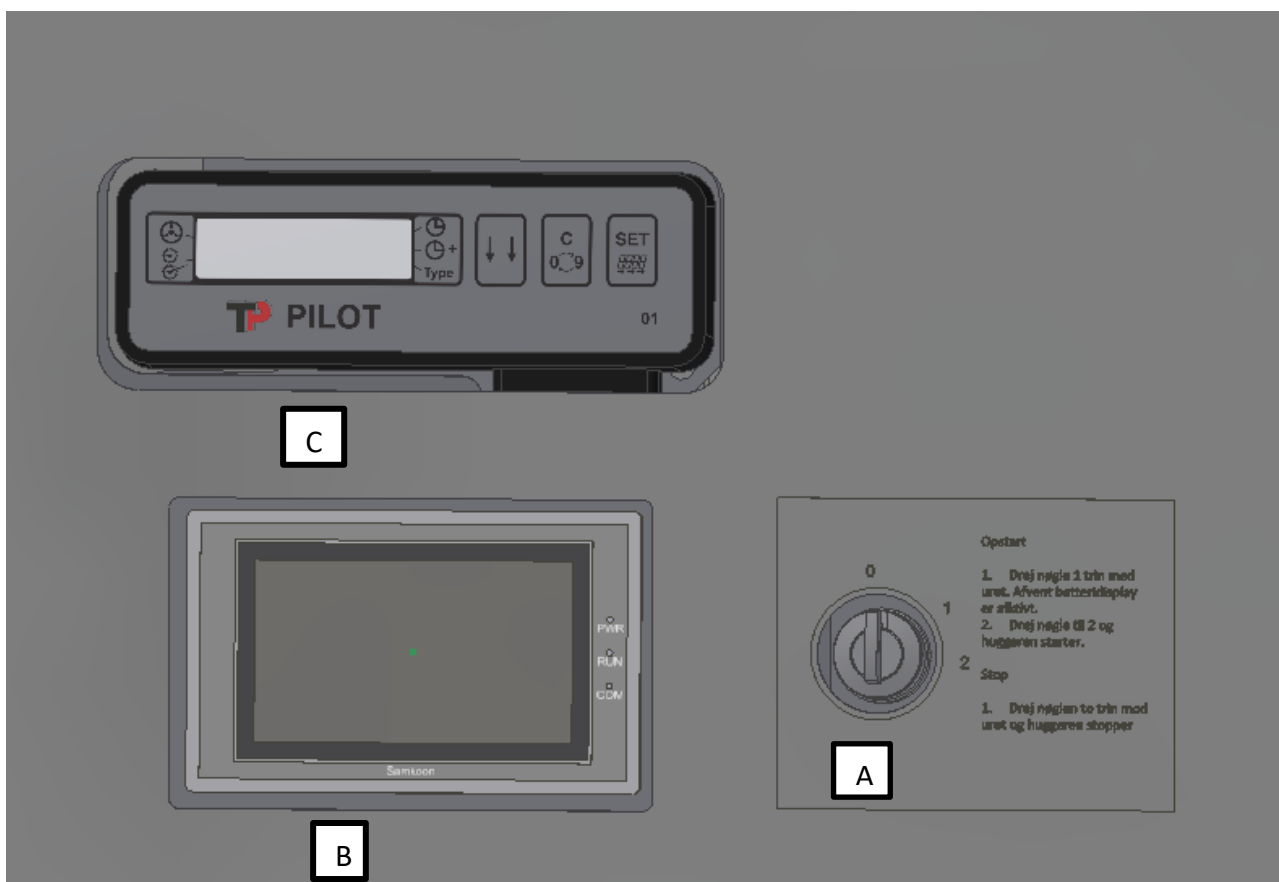

Start the chipper using the key (A)

When in vertical position (0) the key can be removed and the chipper turned off. The battery relay (1) is activated when the key is turned one position clockwise. The battery is now connected to power and the display (B) is activated.

As soon as the display is fully active, the electrical motor can be started by turning the key to position (2). If the key is turned to pos (2) before the display is fully active, the motor will not start. You will then need to turn it back to (1) and then clockwise to (2) again.

The disc is permanently connected to the motor and will start up simultaneously.

Turn off the motor by turning the key back to pos (0).

TP PILOT (C) monitors the disc and feed rollers. In addition, the work time and the total work time can be read (see illustration above and see instructions for TP PILOT later in this chapter).

Current level is shown on a separate display (B).

Prior , to the wood chipper starting, it must be ensured that the TP VARIO SPOUT is at the operating height. (See instructions for TP VARIO SPOUT, earlier in this chapter). (Only applies to models fitted with TP VARIO SPOUT).

## 8.6 Connecting and disconnecting instructions

The wood chipper is a trailer hitched wood chipper and is designed to be fitted behind a vehicle with a trailer hitch, as a coupling without requiring inspection. The wood chipper with trailer and own engine is registered as a trailer tool.

REMEMBER: The wood chipper must always be coupled/uncoupled on a level surface!

### Coupling with straight drawbar (dependent on the model)

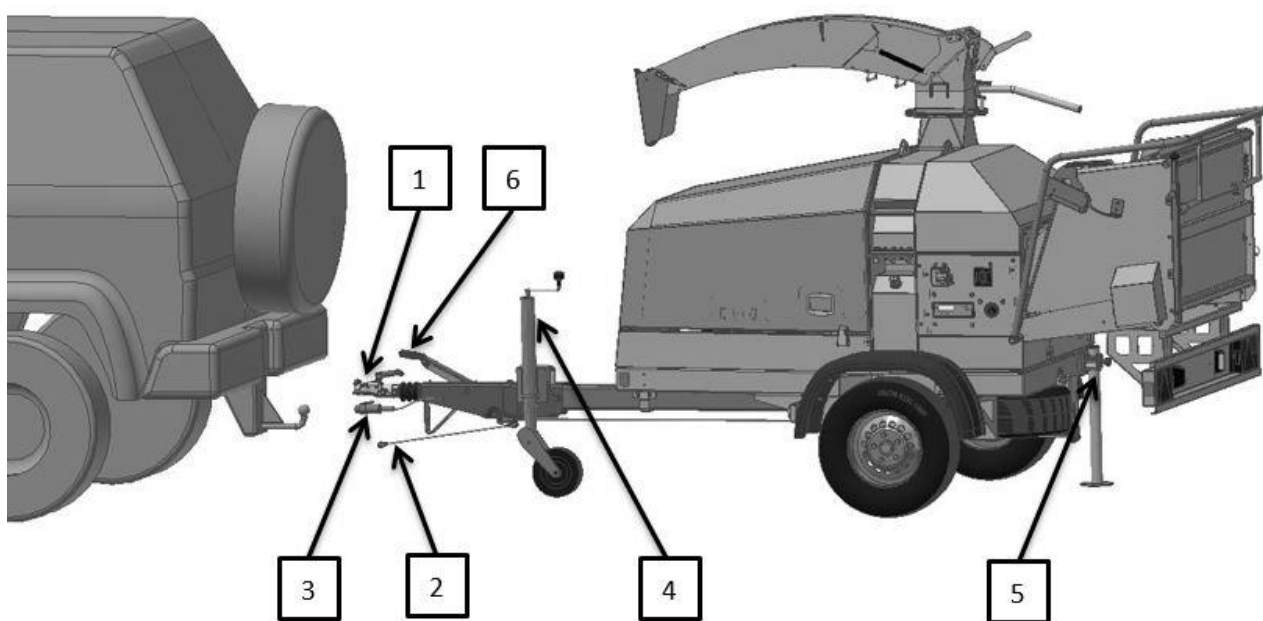

1. Connect the wood chipper to the vehicle by securing the wood chipper's socket coupling (1) onto the trailer hitch on the vehicle.
2. Fit the safety wire (2) to the trailer hitch.
3. Connect the 13-pin connector (3) to the vehicle.
4. Screw up the front jack (4).
5. Push up and secure the rear support leg (5).
6. Loosen the handbrake (6).

### Uncoupling the wood chipper from the vehicle

To correctly uncouple the wood chipper, repeat the above procedures in reverse order.

## 8.7 Foldable funnel

The aim of the foldable funnel is to minimise the total length of the mobile wood chipper during transport and when storing it.

The foldable funnel must always be in the transport position during transport on public roads.

### Transport position

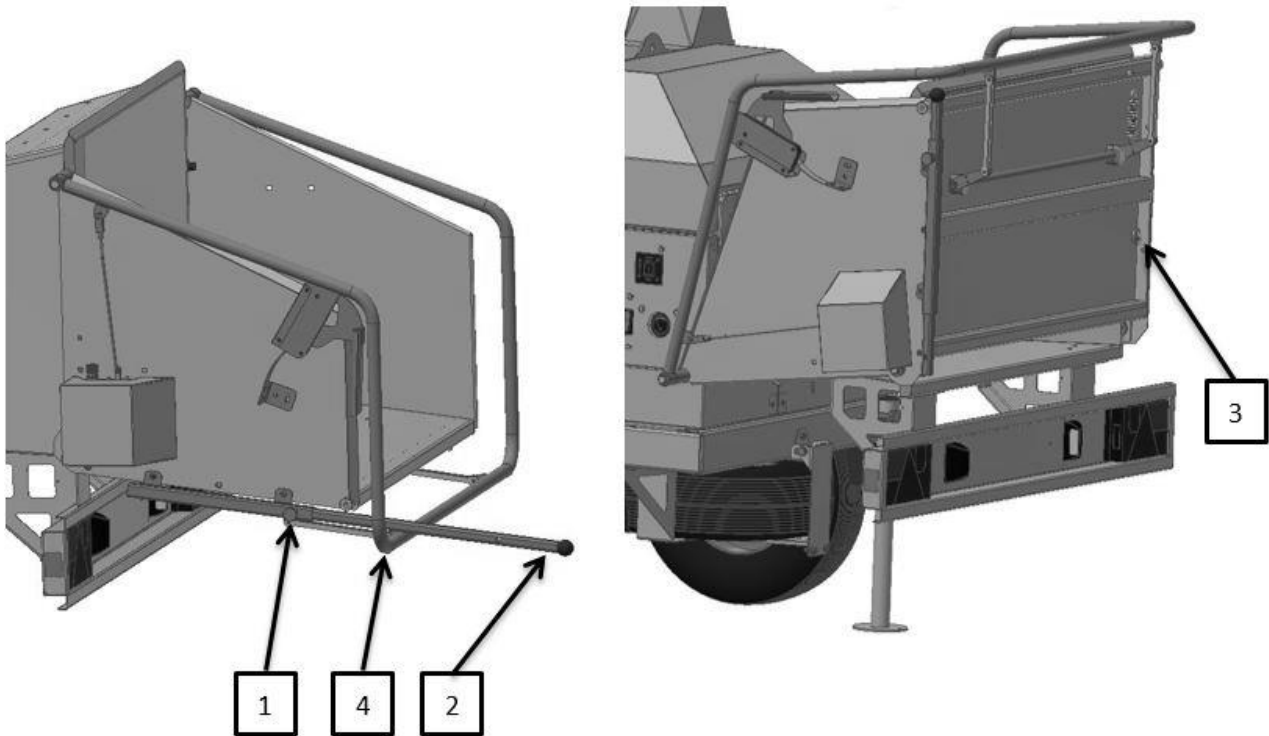

1. Pull out the sliding bolt (1) while pulling out the lever (2). (If fitted, dependent on the model).
2. Now fold up the funnel by lifting the lever (2) (if fitted, dependent on the model). (Use both hands). If the model is not fitted with the lever (2), lift with the manoeuvre bar (4). (Use both hands).
3. Once the funnel is folded up, secure it using the ring pin (3) in the right side.
4. Pull out the sliding bolt (1) and push the lever (2) back into its starting position (if fitted, dependent on the model). The funnel is now in the transport position.

### Operating position

To put the foldable funnel into the operating position, repeat the transport position procedure in reverse order.

## 9 Battery monitoring

Battery state is monitored on the display.

- 1 Battery capacity as a percentage
- 2 Power consumption and charge current
- 3 Maximum cell voltage
- 4 Minimum cell voltage
- 5 Change display language
- 6 Total battery voltage for both cell 1 and cell 2
- 7 Maximum cell temperature
- 8 Minimum cell temperature

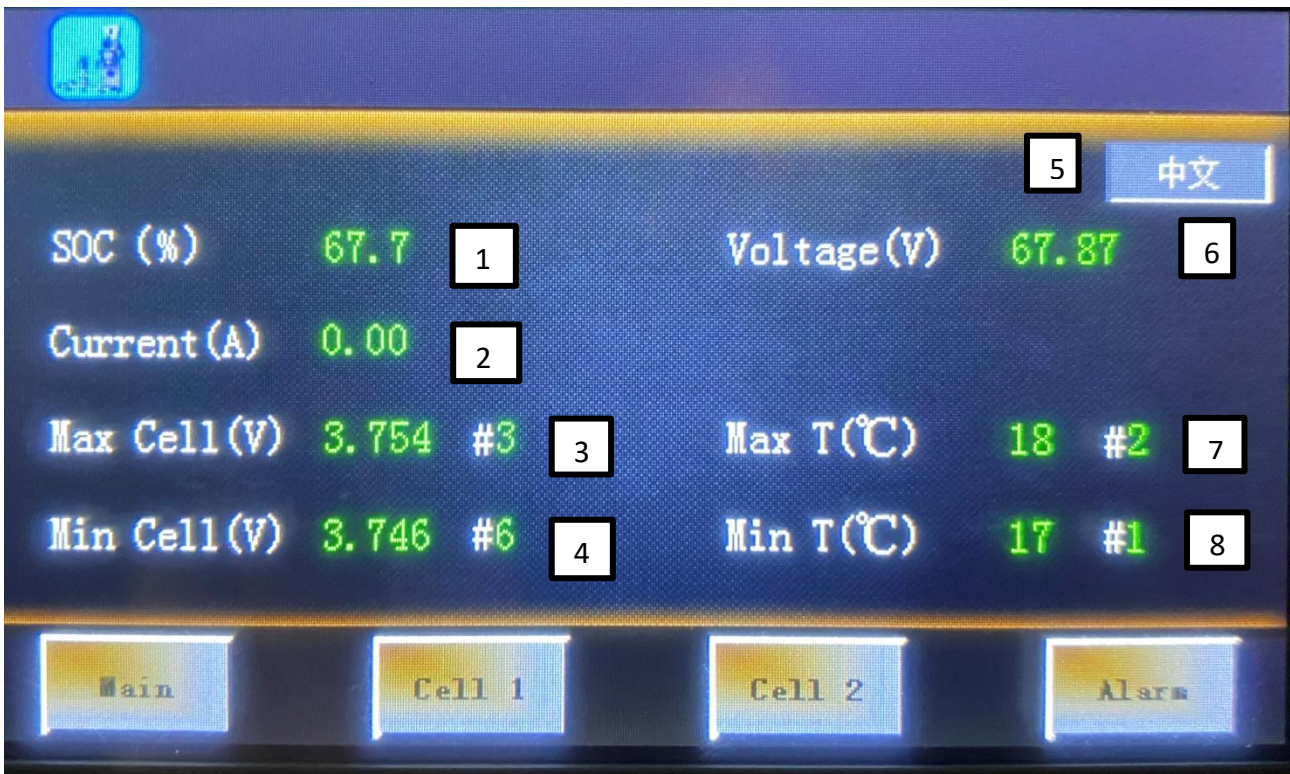

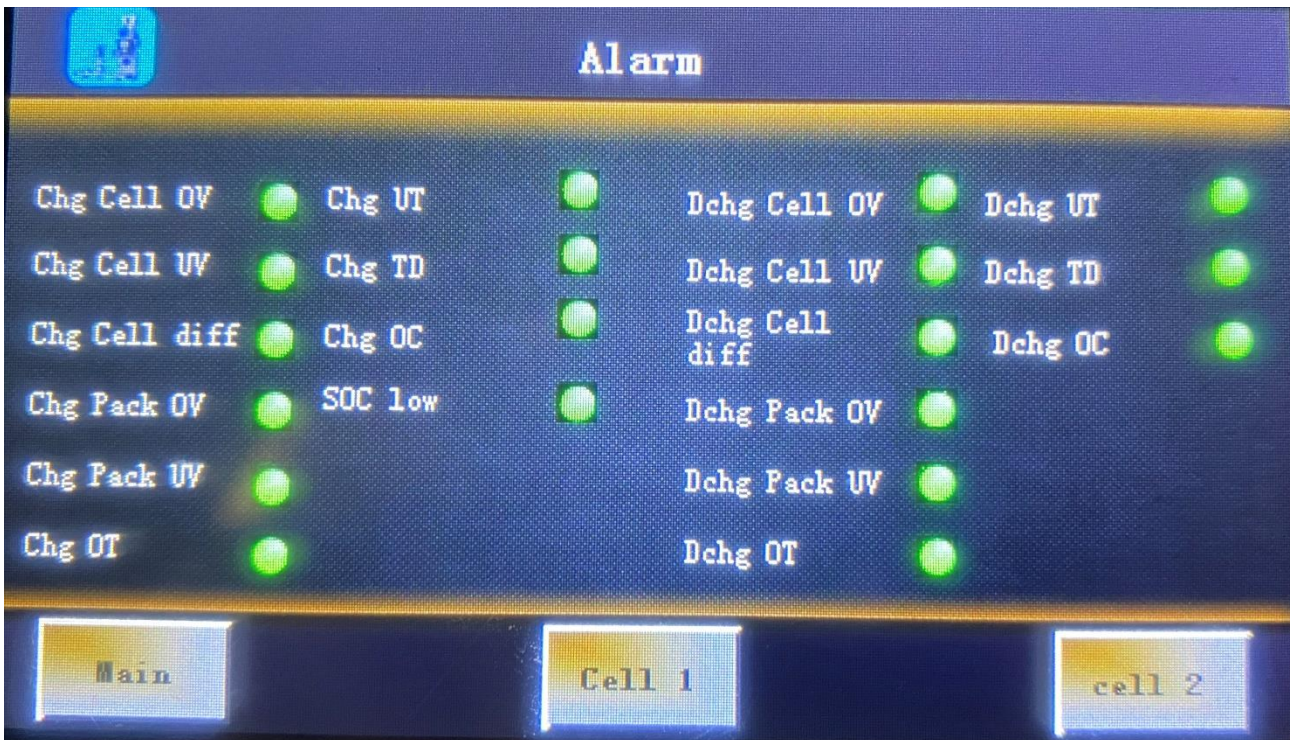

Use the alarm screen to diagnose potential battery problems. All lamps should normally be green.

#### Alarm overview

- Chg Cell OV : Charge cell over voltage
- Chg Cell UV : Charge cell under voltage
- Chg Cell diff : Charge cell difference
- Chg Pack OV : Charge Pack over voltage
- Chg Pack UV : Charge Pack under voltage
- Chg OT : Charge over temperature
- Dchg Cell OV : Discharge cell over voltage
- Dchg Cell UV : Discharge cell under voltage
- Dchg Cell diff : Discharge cell difference
- Dchg Pack OV : Discharge Pack over voltage
- Dchg Pack UV : Discharge Pack under voltage
- Dchg OT : Discharge over temperature
- Dchg UT : Discharge under temperature

## 10 Charging

The battery is charged by connecting the power plug to 230 V AC and turning the key to position (1) until the display is activated.

**Note that the battery can only be charged while the display is active!**

A full recharge of an empty battery will normally take about 10 hours, but this will vary according to temperature. To protect the battery and ensure maximum service life, we do not recommend that you charge the battery at temperatures below 0° C !

## 11 Instructions for rpm monitor TP PILOT

### 11.1 Overall operation

TP PILOT provides the option for monitoring the revolutions of the engine and feed rollers, and sounding an alarm when low or high limit values are exceeded. TP PILOT is pre-programmed for several types of machine.



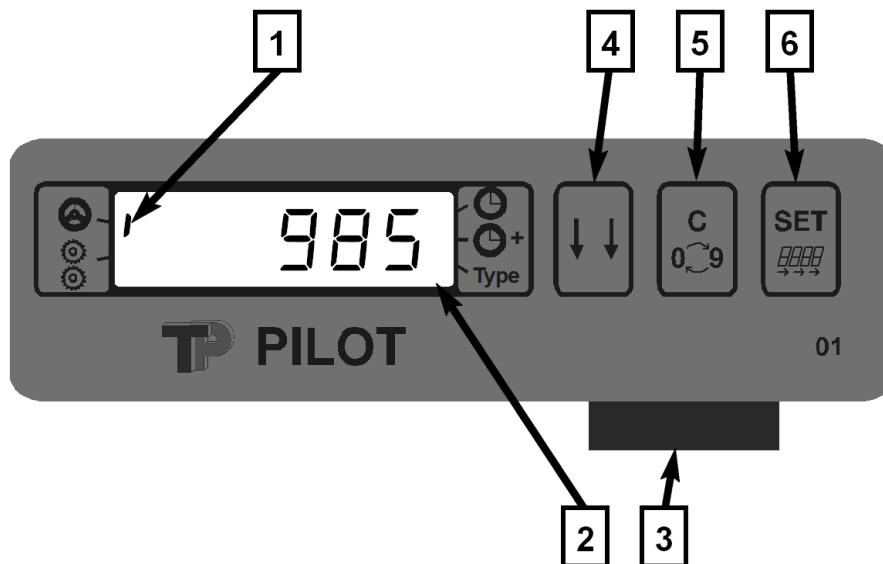

#### Overview of the monitor



- 1. Display marker (1)**  
Indicates which function is currently shown in the display.
- 2. Display (2)**
- 3. Output to junction box (3)**
- 4. NEXT (4)**  
Change between different display indications.
- 5. CHANGE (5)**  
Programming and resetting of numerical values.
- 6. SET (6)**  
Starting changes of the marked value and changing of digits in display.

## Different functions and display indications

Use the NEXT key  to change between the following display indications:

Symbol:	Term:	Display:
	<b>Disc</b> Programmable rpm monitor for disc	12 – 9999 (rpm)
	<b>Roller</b> Programmable rpm monitor for roller	1 – 9999 (rpm)
	<b>Work time</b> (User can reset this)	0.00 – 99.59 (Hours. Minutes) 9999 (Hours)
	<b>Work time total</b> (Cannot be reset)	0.00 – 99.59 (Hours. Minutes) 9999 (Hours)
<b>Type</b>	<b>Pilot programme</b> The pilot programme depends on the model type	1 – 26 (Programmes)

## Explanation for operation keys

The TP PILOT is equipped with an internal memory which saves all values when the power is cut.

### NEXT





Press the  key to change between the different display indications and thus between the different functions of the monitor. With every press of the key, the position of the marker/display indication changes one step.

The key is also used to exit the change menu (see next section).

### CHANGE



Use the  key to change or delete the values that are to be programmed. Before using this key, the applicable value that is desired to be changed should flash. This is done using .

### SET



Use the  key for programming (change/delete) values in the computer, e.g. entering alarm values for high or low rpm.

## 11.2 Programming

The following parameters can be finely-adjusted, as needed:

Parameter	Meaning	Comment
<b>L</b> = Low	Least rpm	Deviation from nominal rpm. If the wood chipper is loaded to under "lowest rpm", the feeding is uncoupled so that the wood chipper has the possibility of reaching normal rpm, at which point the rollers are re-coupled.
<b>h</b> = High	Nominal rpm	Nominal rpm, which the disc must maintain and at which point the in-feed starts.
<b>T</b> (ype)	Machine type	According to the set-up table for machine types



Triggers an alarm on the feed roller. If the rpm on the feed roller exceeds the upper limit value (Roller flashes) the display will blink between the **rpm** value and **high**.

Adjust the roller speed by turning the roller speed controller clockwise.

When the roller speed falls below the limit value again, the current rpm is displayed.

### Entering code

When changing parameters and machine type, the code **1001** must first be entered. Procedure for



















entering code: Use the  key to select what is required to be changed on the display. Press the  key for one second until `_c0000` flashes. Use the  key to enter the first digit of the code

number. Press the  key to move the marker to the next digit in the number and so on, until all the digits are changed/programmed. The required parameters can now be changed.

Finally, press the  key once to leave the menu.

The code must be entered with every change.

Here you can see an example of the programming of limit values on the disc.

Example of changing low limit value to 800 rpm and high limit value to 1000 rpm		
Press the key:	The display shows:	Explanation:
	0	Press the key repeatedly until the display marker is next to 
	L_850	Press the key for one second and enter the <b>access code</b> . L lights up on the left and the first digit (four digits in total) flashes.
	L X800	Press the key until the digit has the correct value. NB: Zero is shown as _ in this position.
	L_X00	Press the key to set/change the next digit (the second digit will now flash).
	L_800	Press the key until the desired digit is correct.
	L_8X0	Press the key to set/change the next digit (the third digit will now flash).
	L_850	Press the key until the desired digit is correct.
	L_85X	Press the key to set/change the last digit.
	L_850	Press the key until the desired digit is correct.
	h_980	Press the key and "h" (high) will light up to the left and the first digit (of four) will flash.
	hX980	Press the key until the desired digit is correct. NB: Zero is shown as _ in this position.
	h1980	Press to set/change the next digit (the second digit will now flash).
	h1x80	Press the key until the desired digit is correct.
	h1080	Press to set/change the next digit (the third digit will now flash).
	h10X0	Press the key until the desired digit is correct.
	h1000	Press to set/change the last digit.
	h100x	Press the key until the desired digit is correct.
	h1000	Press to exit the programming menu.

When an alarm limit on the disc is exceeded, the current rpm is still shown while the feed rollers are stopped. If the disc has been under the lower limit value, the feed rollers will start again when the disc's rpm is above the set upper limit value 'h' (e.g. 1,000 rpm).

**Set-up table for included machine types**

Model	Disc rpm	rpm 1 L	rpm 1 h	Type No.
TP 175 MOBILE ZE	1482	1340	1450	16

## Work time on the wood chipper



### Displaying the rotation time on the wood chipper





With this display, the display marker is shown next to work time . The work time will be shown as illustrated in the figure below. In the example, the wood chipper has operated for 72 hours and 57 minutes.



If over 99:59 hours/minutes, only whole hours are shown.

### Resetting the rotation time on the wood chipper

Resetting the rotation time (operation time) on the wood chipper can be done at any time. First, press the  key until the display for work time  appears. Next, enter the following:

Press the key:	The display shows:	Explanation:
	72:57 (example)	Press repeatedly until the display marker is next to  .
	72:57	Press the key for five seconds until the number blinks.
	00:00	Press the key to reset the rotation time.

NB: Total hour counter (bottom vertical marker) cannot be reset. It is used for registering the wood chipper's total work time.

### 11.3 Monitoring diagram

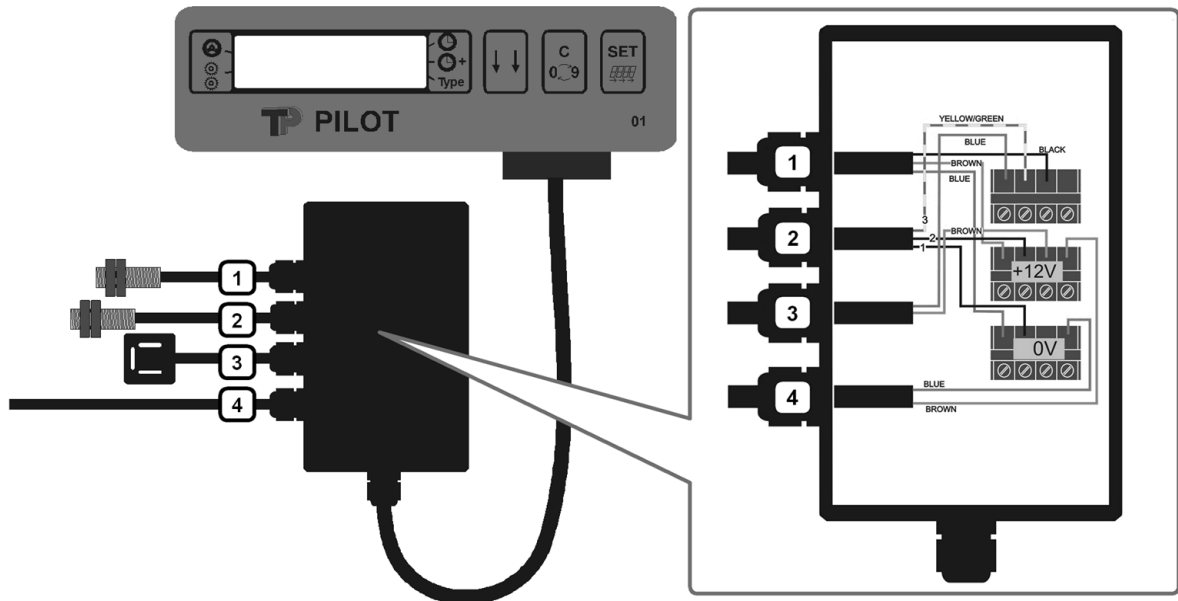

- 1. Disc, inductive sensor (1)
- 2. Roller, hall sensor (2) (only on TP 155 MOBILE)
- 3. Valve (3)
- 4. Power (4), 12 V

### 11.4 Technical data

Display: Six digits

Power supply: 12 VDC / 1.24 A

Temperature ranges: TP PILOT is fully operational in the temperature range -10 to +70 °C.

Pulse signals from sensor: Max. 225 pulses/second

## 12 Maintenance

The wood chipper must be inspected every day. This includes opening the disc housing and checking the feed, disc, knives, counterknives, triangle scraper and square scrapers. This will ensure that unexpected stoppages are avoided and prolong the life of the wood chipper.

When carrying out maintenance and repairs, the wood chipper must be stopped, and the wood chipper key must be removed from the ignition before the disc housing is opened. (see opening and closing of disc housing in chapter 7). In addition, the wood chipper must also be positioned on a level, flat surface when carrying out maintenance and repairs.

## 12.1 Maintenance schedule for wood chipper

X = for each stated time interval

(X) = Only for the first time

\* = or once a week

Interval=> daily/hours	10* ⌘	50 ⌘	250 ⌘	1000 ⌘
Check the safety bar function <sup>1</sup>	X			
Check the knives and counterknives (and sliver breaker - extra equipment)	X			
Check the hydraulic oil level	X			
Tighten all bolts and nuts	(X)	(X)		
Lubricate the main bearings for the disc <sup>2</sup>		X		
Lubricate the roller bearings <sup>2</sup>		X		
Lubricate TP VARIO SPOUT <sup>2</sup>		X		
Lubricate fixed ejector spout <sup>2</sup>		X		
Lubricate safety switch <sup>3</sup>		X		
Replace hydraulic pump return filter <sup>6</sup>		(X)		X
Reverse/replace horizontal counterknife			X	
Replace vertical counterknife			X	
Reverse or replace square scrapers and scrapers			X	
Replace hydraulic oil <sup>4</sup>				X
Replace facing plate in top disc housing (extra equipment) <sup>5</sup>				X
Check ejector wings for wear and tear				X
Check casing for wear and tear				X
Check belt tension on electric motor		X		

<sup>1</sup> Always execute before use! Pay particular attention to ensuring that the rollers do not rotate when the safety bar is in the stop position. See also chapter 8.

<sup>2</sup> Lubricate two lubrication nipples with Uniway Li62 or equivalent lubricant.  
In case of light use: Lubricate after 12 months.

<sup>3</sup> Lubricate the safety switch at the bonnet with lubricating oil spray or chain oil spray. If the safety switch is defective, it must be changed immediately.

<sup>4</sup> Drain the hydraulic oil and fill with new oil. See the hydraulic oil table below for oil type and amount.

<sup>5</sup> If fitted, change the facing plate in the top disc housing as necessary.

<sup>6</sup> Replace after 12 months.

## 12.2 Hydraulic oil table

Model type	Standard oil type	Bio-oil (optional) <sup>1</sup>	Quantity in litres
TP 155 MOBILE	Hydraway HVXA 46	Hydraway SE 46 HP	12 L
TP 175 MOBILE STAGE V	Hydraway HVXA 46	Hydraway SE 46 HP	12 L

TP 175 MOBILE	Hydraway HVXA 46	Hydraway SE 46 HP	12 L
TP 175 MOBILE P	Hydraway HVXA 46	Hydraway SE 46 HP	12 L
TP 215 MOBILE	Hydraway HVXA 46	Hydraway SE 46 HP	25 L

<sup>1</sup>The interval between changing oil can be extended by using biodegradable oil, which can be purchased as extra equipment.

### 12.3 Check of hydraulic oil level

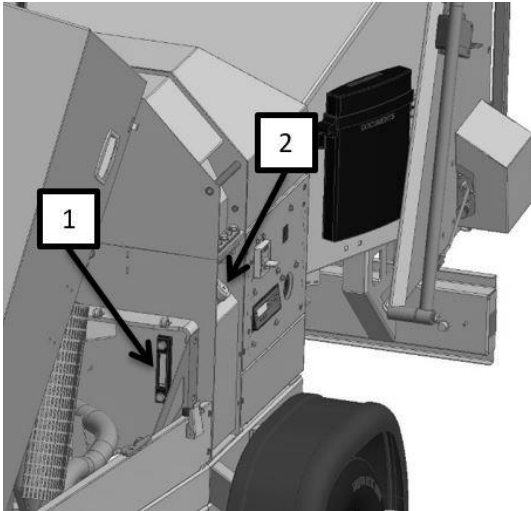

1. Stop the wood chipper and the engine. Open the bonnet, which is locked with an external catch on each side.
2. Check that the hydraulic oil level is at the middle in the level glass (1).
3. If the hydraulic oil level is too low, refill with hydraulic oil. To ensure use of the correct oil quality, see the hydraulic oil table shown earlier in this chapter. When filling with oil, use the same type of oil or an oil with equivalent specifications. Do not mix oils of different types/brands.
4. To fill, loosen the filler neck (2) and fill with hydraulic oil until the level is at the middle in the level glass (1). (Dependent on the model, it may be necessary to open the disc housing to gain access to the filler neck (2).) (See Open the disc housing as described in chapter 7). (See also illustration below).

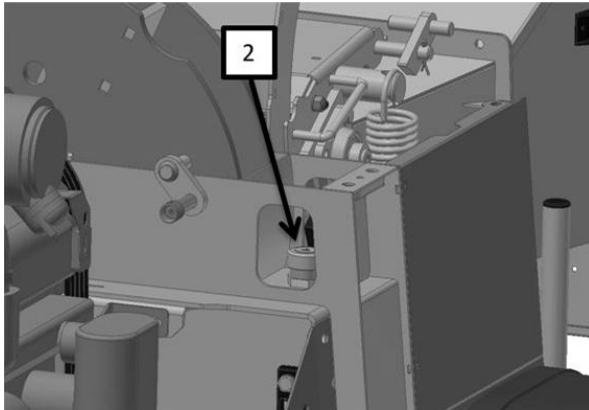

5. Subsequently re-fit the filler neck (2).
6. Close the bonnet and lock it using the external catches. (Dependent on the model, close the rotor housing and bonnet). (See Close the disc housing and bonnet as described in chapter 7).

## 12.5 Lubrication

To lubricate the wood chipper bearings and safety switch:

1. Open the bonnet as described in chapter 7. (See also illustrations below).

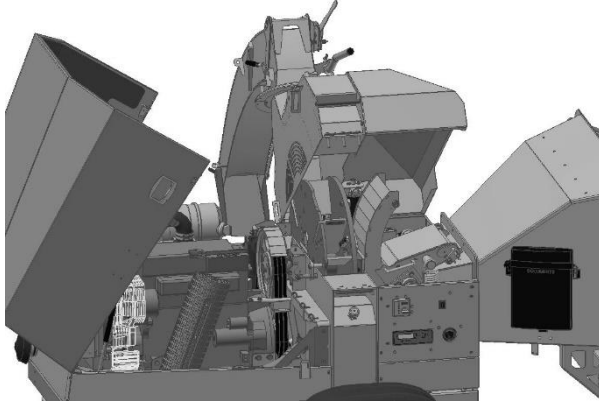

2. You now have free access to grease lubricate the two grease nipples on the main bearings (1) and the two lubrication nipples on the roller bearings (2) and to oil lubricate the safety switch (3). (See illustrations below).

To use the correct quality of grease and lubricating oil, see the maintenance schedule for the wood chipper, shown earlier in this chapter.

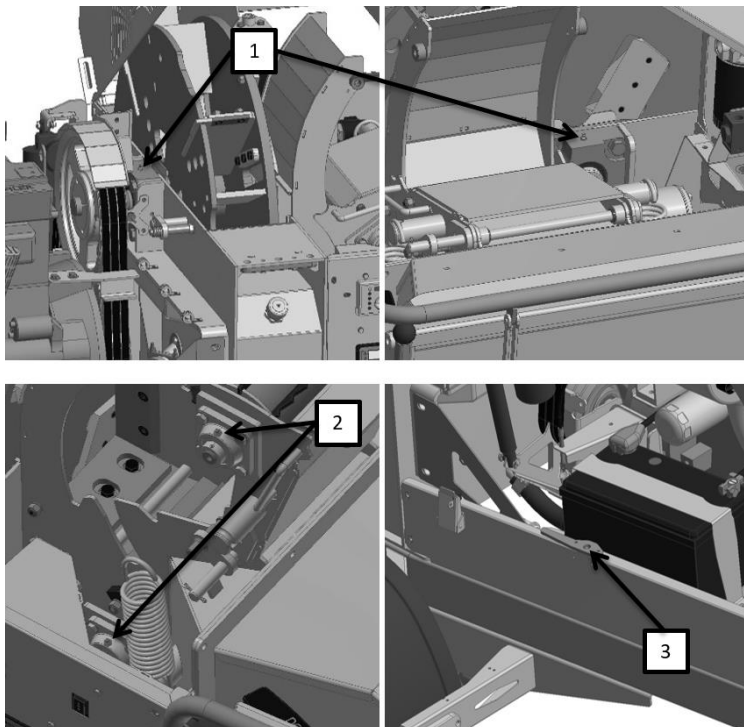

3. Close the disc housing and bonnet as described in chapter 7.
4. Lift up the ejector spout to the operating height. (Only applies to models fitted with TP VARIO SPOUT). (See Operating the wood chipper in chapter 8).

5. Lubricate the lubrication nipple on the fixed ejector spout (2) or the two lubrication nipples on TP VARIO SPOUT(3). (Dependent on the model). (See illustrations below).

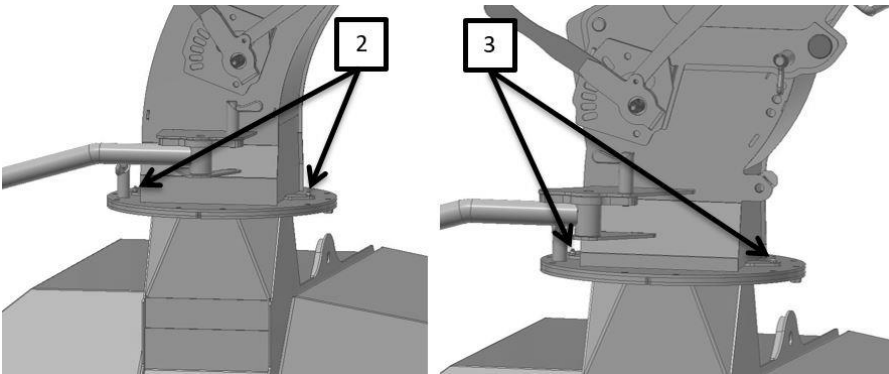

6. Next, completely lower the ejector spout and ensure that it is locked securely again. (Only applies to models fitted with TP VARIO SPOUT). (See Operating the wood chipper in chapter 8).

## 12.6 Hydraulic oil change

The wood chipper is filled at the factory with mineral hydraulic oil as standard (bio-oil may be purchased as extra equipment (see the hydraulic oil table, shown earlier in this chapter). When replacing the oil, use the same type of oil or an oil with equivalent specifications. Do not mix oils of different types/brands.

Old hydraulic oil must be handed in to the municipal receiving station.

### Replacing of hydraulic oil and return filter

1. Open the bonnet as described in chapter 7. (See also illustrations below).

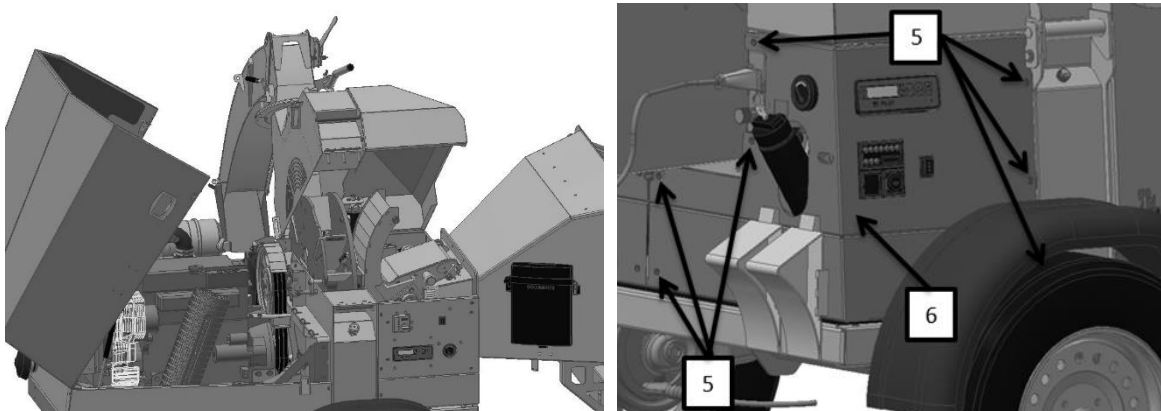

(Only on TP 155 and TP 175)

2. Loosen the seven bolts (5) and remove the side cover (6), which opens up access to the return filter  
(Only on TP 155 TP 175 and TP 175 P).

---

You now have free access to the drain plug, return filter, breather plug, filler neck and level glass. (See illustrations below).

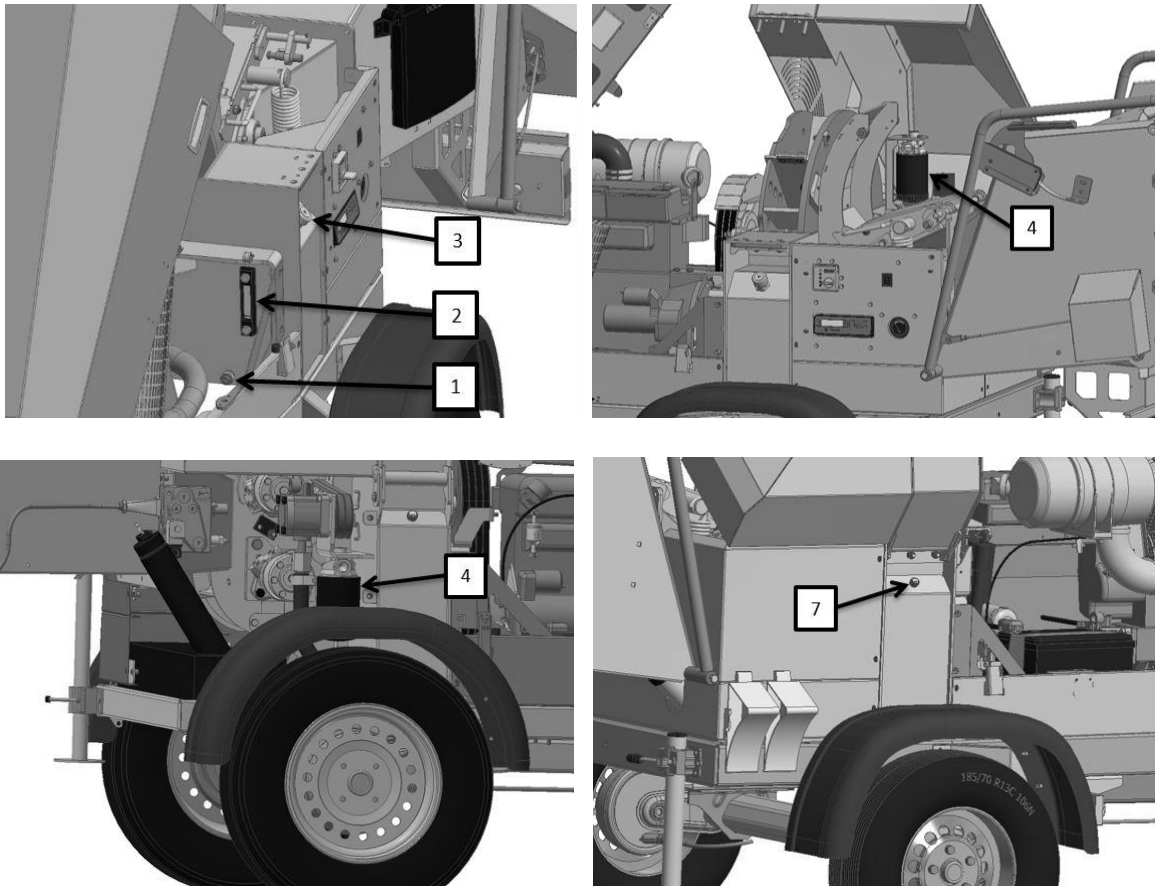

3. Remove the filler neck (3).
4. Unscrew the drain plug (1) and capture the oil in a container for suitable disposal.
5. When the tank is almost empty, suck the tank empty using an oil suction device.
6. Replace the return filter (4) with a new filter.
7. Screw the drain plug (1) back on.
8. Remove the breather plug (7) and slowly refill with new hydraulic oil. Fill the oil until the oil level is at the middle of the level glass (2).
9. Lastly, re-fit the filler neck (3) and the breather plug (7).
10. Re-fit the side cover (6) using the seven bolts (5). (Only on TP 155, TP 175 and TP 175 P).
11. Close the disc housing and bonnet as described in chapter 7.

## 12.7 Blades

The wood chipper is equipped with knives (two or four, dependent on the model).

The blades must always be changed as a set. The blades belong together in sets, also when sharpening, to ensure they are always the same width. If the blades are not of equal width, the disc will be out of balance, which will lead to unnecessary load on the bearings and vibrations in the whole wood chipper.

### Replacing blades

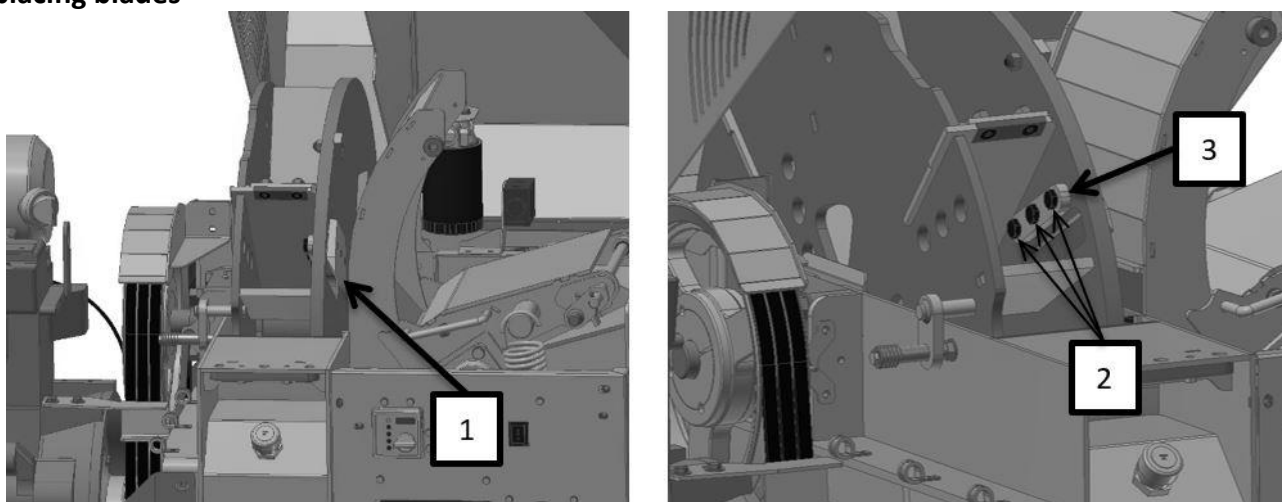

1. Open the disc housing as described in chapter 7.
2. Remove the bolts (2) (two or three, dependent on the model) that hold the knives and clamping plates (3)/silver breaker securely to the disc.
3. Remove the blades and sharpen/replace.
4. Carefully clean the knives (1), clamping plates (3)/silver breaker and contact faces.
5. When fitting the knives (1), the bolts (2) must be lightly oiled ( $\mu = 0.125$ ), i.e. light oil, WD 40 or an equivalent product. Do not use copper grease, MoS<sub>2</sub> or similar low friction grease.
6. Check that the distance between the knife edge and the counterknife is set correctly to **D** (as described later in this chapter).  
Inspect all of the blades.
7. Tighten the bolts (2) (two or three, dependent on the model) to **110 Nm / 11 Kpm**. Use a torque wrench to do this.  
(Available as extra equipment).

8. Finally, close the disc housing as described in chapter 7.

## Sharpening blades

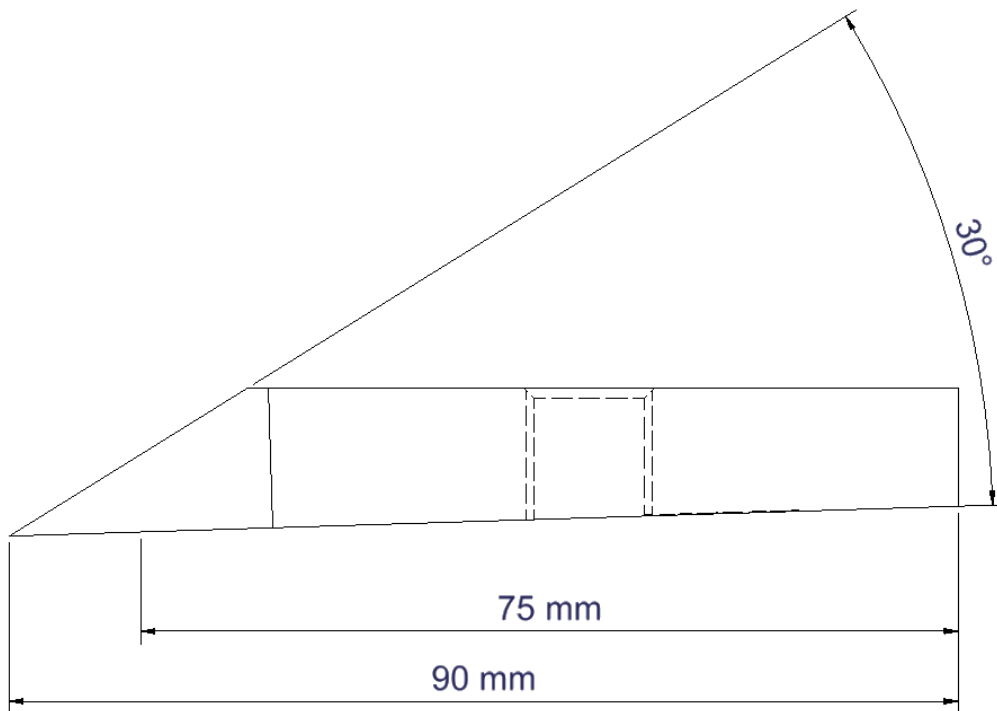

It is very important for woodchip quality that the blades are sharp. They must be checked at least once a day. Blade sharpening intervals can be extended by regularly sharpening with a carborundum stone.

Grinding must be performed as wet grinding with a header. Never use an angle grinder or a similar tool to sharpen blades.

When sharpening blades, ensure that the width of the blades in the set is uniform. Their widths must be identical, to keep the disc in balance. This means that blades must always be sharpened in sets. The blades must not be ground down to a width of less than 75 mm. After that they must be discarded.

The edge of the blades must be ground at an angle of 30°

## 12.8 Counterknife

The counterknife in the wood chipper is used by the knife to cut the wood. The counterknife must have a sharp edge otherwise the wood will bend and the cutting face become frayed. The wood chipper is equipped with a vertical counterknife (one or two, dependent on the model) in the sides of the in-feed and a horizontal counterknife in the base. The horizontal counterknife has two cutting edges and therefore can be reversed.

### Changing the counterknife

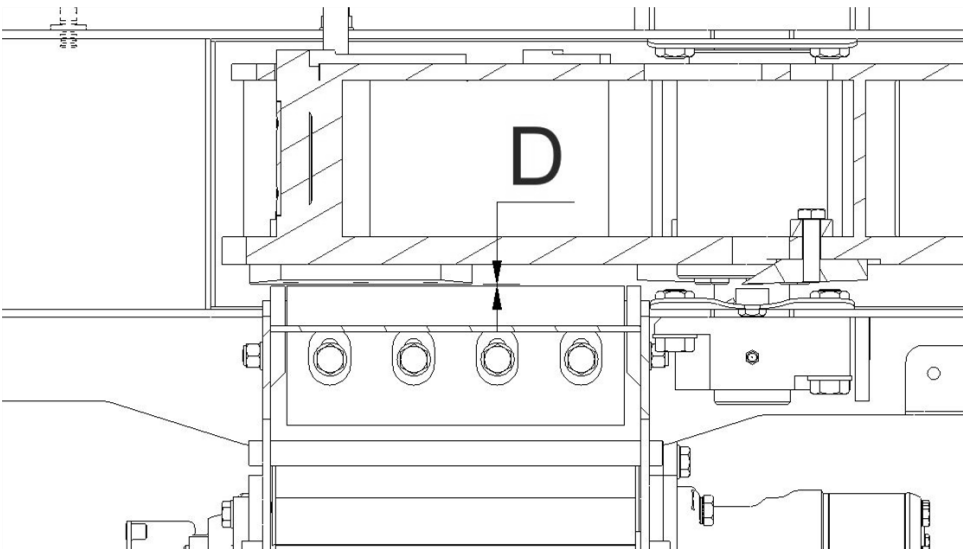
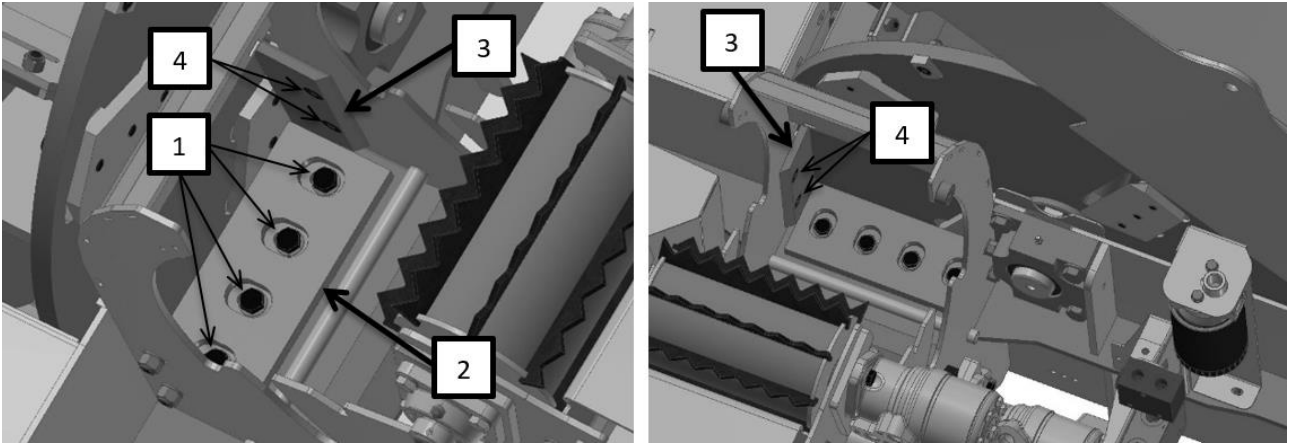

**D = 1.5 mm**

1. Open the disc housing as described in chapter 7.
2. Open the roller console as described in chapter 7.
3. Remove the M10 countersunk bolts (4), which hold the vertical counterknife in place (3) (one or two, dependent on the model).
4. Remove and replace the vertical counterknife (3) (one or two, dependent on the model).

5. Remove the M12 bolts (1) (three or four, dependent on the model), which hold the horizontal counterknife (2) in place.
6. Remove the horizontal counterknife (2) and reverse or replace.
7. Carefully clean the counterknife (2,3) and contact surface.
8. Re-fit the counterknives (2,3) and adjust the distance between the knife edge and the counterknife to distance **D** using a precision feeler gauge (see illustration above).
9. The bolts in the horizontal counterknife (2) must be tightened to:  
**100 Nm / 10 Kpm.** (For TP 155, TP 175 and TP 175 P)  
**110 Nm / 11 Kpm.** (For TP 215)  
Use a torque spanner for this purpose (available as extra equipment).
10. The bolts in the horizontal counterknife (3) must be tightened to **50 Nm / 5 Kpm.** Use a torque wrench to do this. (Available as extra equipment).
11. Once the counterknives (2) have been reversed or replaced (3) and all of the bolts (1,4) have been tightened, close the roller console as described in chapter 7.
12. Finally, close the disc housing as described in chapter 7.

## 12.9 Wipers and scrapers

The wood chipper is equipped with square wipers on the disc (one or two, dependent on the model) and a triangle wiper in the disc housing. The disc is also fitted (dependent on the model) with four scrapers. The purpose of the square and triangle wipers is to remove material that can get stuck by the knives. At the same time, the square wiper removes material which falls off in front of the disc. The square wiper and scraper reduce fuel consumption and wear on the casing. Both the square wiper and scraper can be reversed once, before being replaced, while the triangle wiper should always be replaced when it is worn. The square wipers belong together as a set and must always be replaced in pairs. The same also applies to the scrapers, which also come as a set and must be replaced in pairs.

### Changing the scrapers

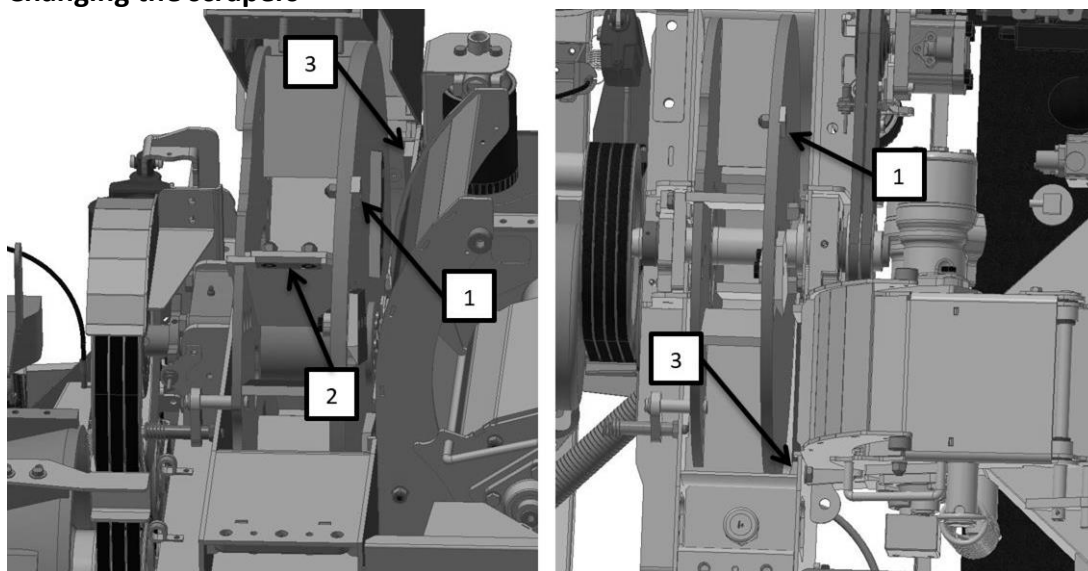

1. Open the disc housing as described in chapter 7.
2. Remove the square scrapers (1) (one or two, dependent on the model), the four scrapers (2)(dependent on the model), and the triangle scraper (3).
3. Reverse the square scraper (1) 180 degrees around the bolt hole, so that the worn corners face in towards the disc's centre of rotation. If both corners or sides are worn, replace the scrapers.

Reverse the scraper (2) (dependent on the model) 180 degrees so that the worn side faces into the disc's centre of rotation. If both sides are worn, replace the scrapers.

The triangle scraper (3) cannot be reversed and must always be replaced.

4. Clean the contact surfaces and the scrapers (1,3)/scraper (2) and re-fit.
5. Finally, close the disc housing as described in chapter 7.

## 12.10 Pump transmission

The feed rollers are driven hydraulically. On the TP 215, the hydraulic pump for the feed roller is fitted directly inside on the engine and thus is driven directly by mechanical power transmission. On the TP 155, TP 175 and TP 175 P, the hydraulic pump for the feed roller is driven by the V-belts. The V-belts must be checked regularly or whenever the belts are suspected of being slack.

### Adjusting the V-belts

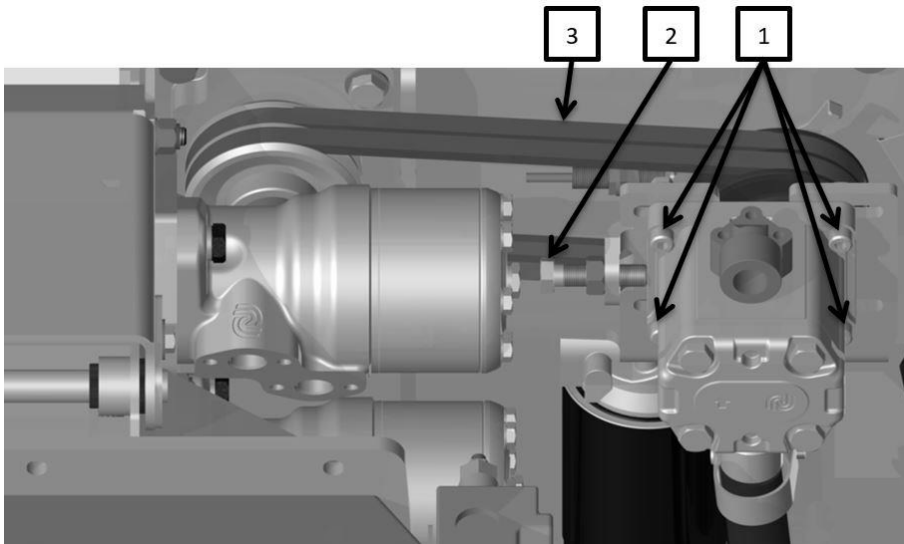

1. Open the disc housing as described in chapter 7.
2. Remove the four bolts (1) which hold the hydraulic pump in place.
3. Adjust the tension using by using the adjusting screw (2). Used belts are allowed to bend 5.5 mm when they are pushed down with 20 N (2 kg), for new belts this value is 23 N (2.3 kg).  
The belt tension can be measured with a gauge for this (available as extra equipment).
4. Tighten the four bolts (1) which hold the hydraulic pump in place.
5. Finally, close the disc housing as described in chapter 7.

## 12.11 Related to battery

### Welding



When welding on the wood chipper, the frame cable that is connected to the battery's negative pole must always be disconnected (look for the "-" symbol on the battery).

## 13 Hydraulic system

### 13.1 Replacing hydraulic hoses

If a hydraulic hose bursts, it must be replaced. All TP hydraulic hoses are stamped with a product number in the hose's fitting. This product number is used to identify the hydraulic hoses.

When replacing hydraulic hoses, always use original TP hoses.

### 13.2 Hydraulics diagram TP 175 MOBILE MOBILE ZE

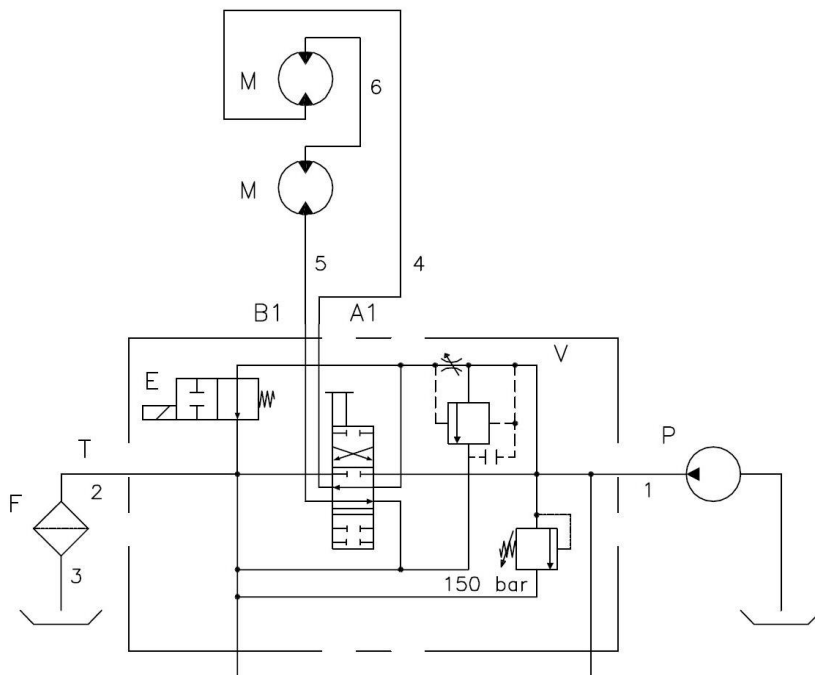

### 14 Electrical diagram TP 175 MOBILE MOBILE ZE

The electrical diagram for both the engine and wood chipper is shown here.

The diagrams and power line are so comprehensive that they are divided into several images, with interfaces where appropriate.

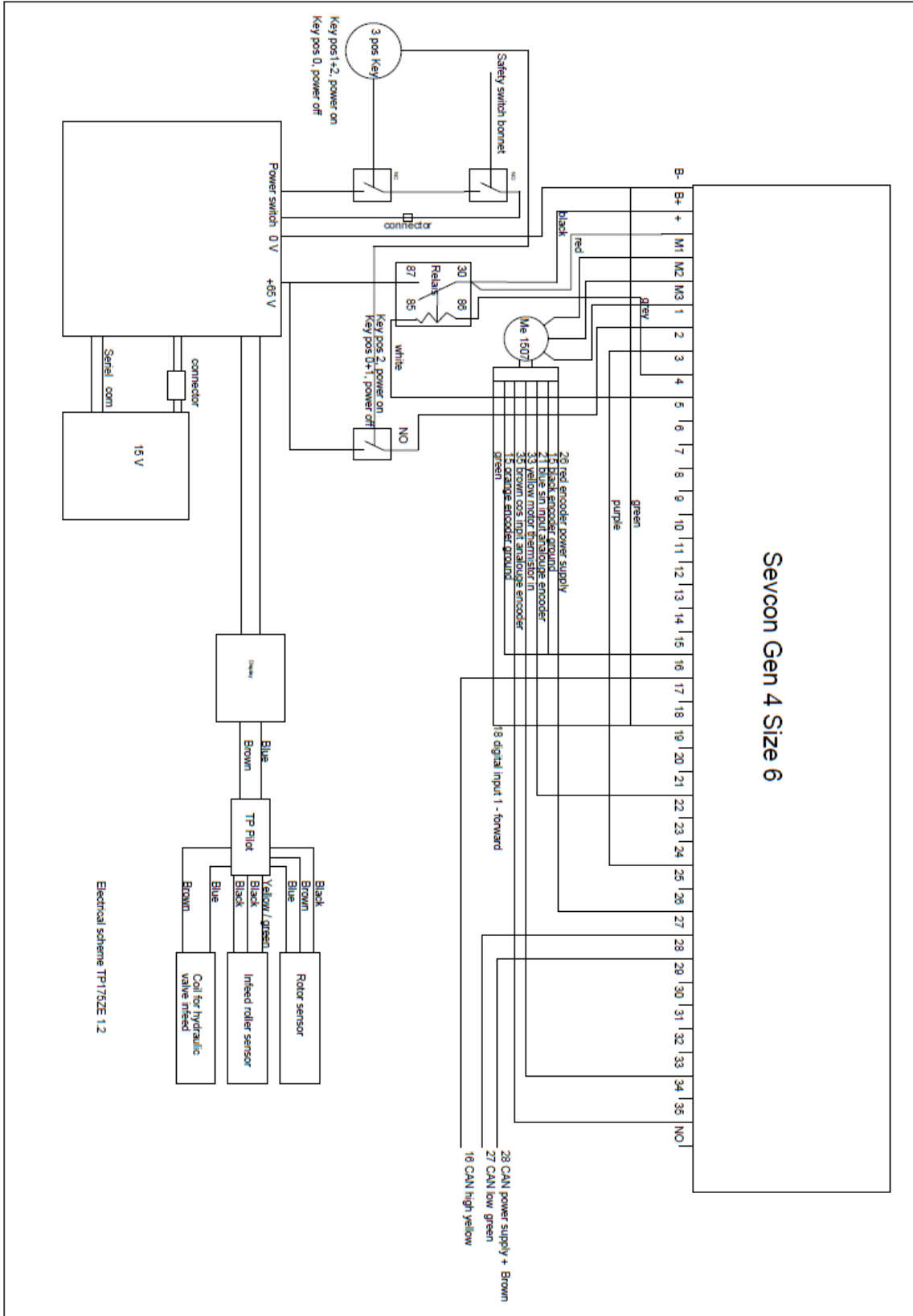

Electric Diagram B065N288LD - Revision 1 - February 2020

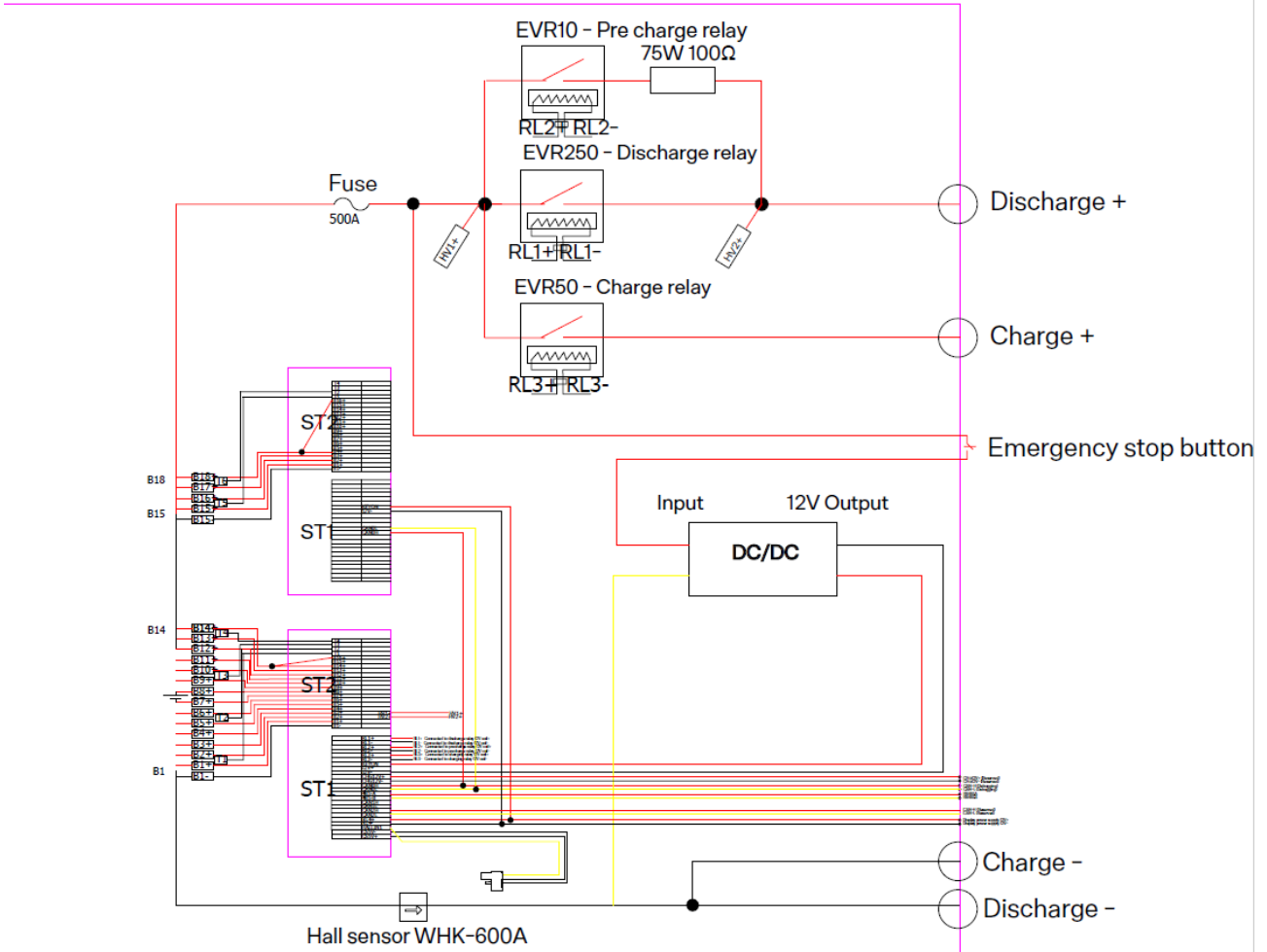

14.1 Diagram trailer

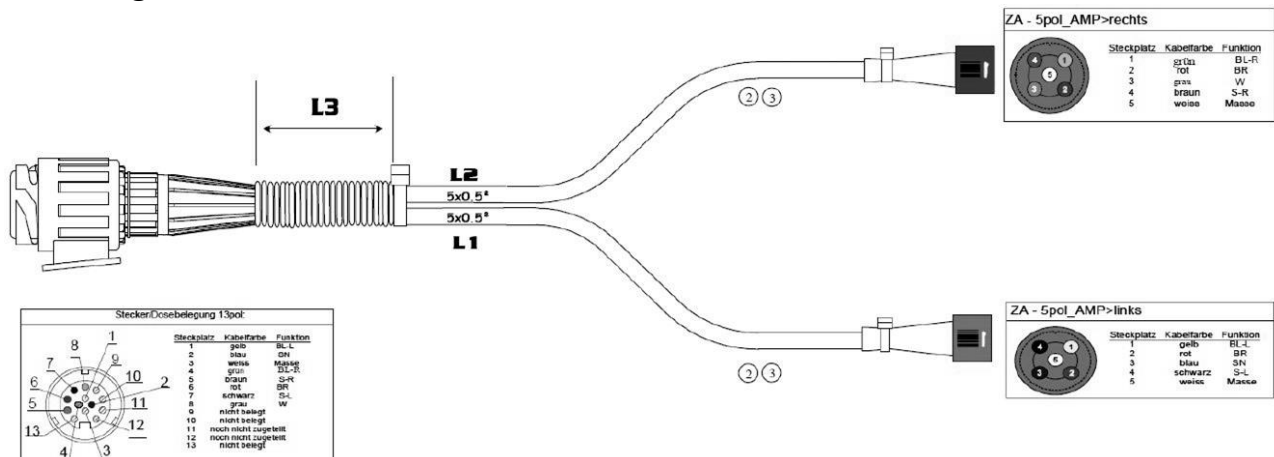

## 16 Troubleshooting

Check possible causes before contacting the supplier.

<b>Problem/Possible Cause</b>	<b>Solution</b>
<p><b>The rollers do not turn:</b></p> <p><i>The operation bow is in the 0 position.</i>  <i>The roller speed controller is screwed out too far (Dependent on the model)</i>  <i>The rollers are blocked</i>  <i>Bypass valve to rpm monitor is dirty</i>  <i>rpm monitor is not connected to the rollers</i></p>	<p>Put the operation bow in the A position  Turn up the flow</p> <p>Clean below and behind the blocked roller(s)  Clean the bypass valve.  Check rpm value on disc/engine</p>
<p><b>The rollers rotate too slowly:</b></p> <p><i>Chip size set for too low a value (Dependent on the model)</i>  <i>Not enough oil in the hydraulics system</i></p>	<p>Increase chip size by turning up the flow</p> <p>Fill up with hydraulic oil</p>
<p><b>Pulling power in the rollers is impaired:</b></p> <p><i>The hydraulic oil is becoming too hot</i>  <i>The V-belts are too slack (Dependent on the model)</i>  <i>The hydraulic filter is blocked</i>  <i>The pressure control valve at the roller speed regulator is dirty</i>  <i>Hydraulic oil is worn</i>  <i>The oil pump is worn or damaged</i>  <i>The oil engine is worn or damaged</i></p>	<p>Let the wood chipper cool down while checking why  Tighten the V-belts</p> <p>Replace the hydraulic filter.  Clean the pressure control valve.</p> <p>Change the hydraulic oil  Replace the hydraulic pump  Replace the oil engine</p>
<p><b>Unsatisfactory woodchip quality:</b></p> <p><i>The blades are blunt.</i>  <i>The counterblades are worn.</i>  <i>The blades are excessively worn.</i>  <i>The distance between blades and counterblades is too great,</i>  <i>Sliver breaker not mounted or worn</i>  <i>Facing plate is not fitted</i></p>	<p>Sharpen the knives.  Reverse/replace counterblades.  Replace the blades.  Adjust the distance between blades and counterblades.  Fit or replace the sliver breaker.  Fit facing plate</p>
<p><b>Poor ejection of woodchip:</b></p> <p><i>Not enough driving power</i>  <i>Scrapers are worn.</i>  <i>The facing plate in the top part.</i></p>	<p>The engine does not provide sufficient power  Replace the scrapers  Remove the facing plate from the top part</p>

## **17 Warranty terms – wood chipper**

Please refer to the provided warranty certificate.

## 18 Technical data wood chipper

Type	TP 175 MOBILE EZ-E
Turntable	No
Rotation angle	0°
Height-adjustable drawbar	No
Chipping principle	Disc chipper
Disc diameter, mm	599
Disc weight, kg	69
rpm disc	1450
Total number of blades	2
Engine	ME1507
Power, kW/(HP)	11 kW
Fuel type	65V dc
Max. wood diameter, mm	175
Chip length, mm	4–12
Knife position, mm	12
Tyre fitting	155/80R13
Tyre pressure, bar/PSI	4.5/65
Deadweight without extra equipment, kg	830
Permitted total weight, kg	950

We reserve the right to make changes to the design and specifications without notice.

## Dimensional drawing for TP 175 ZE MOBILE

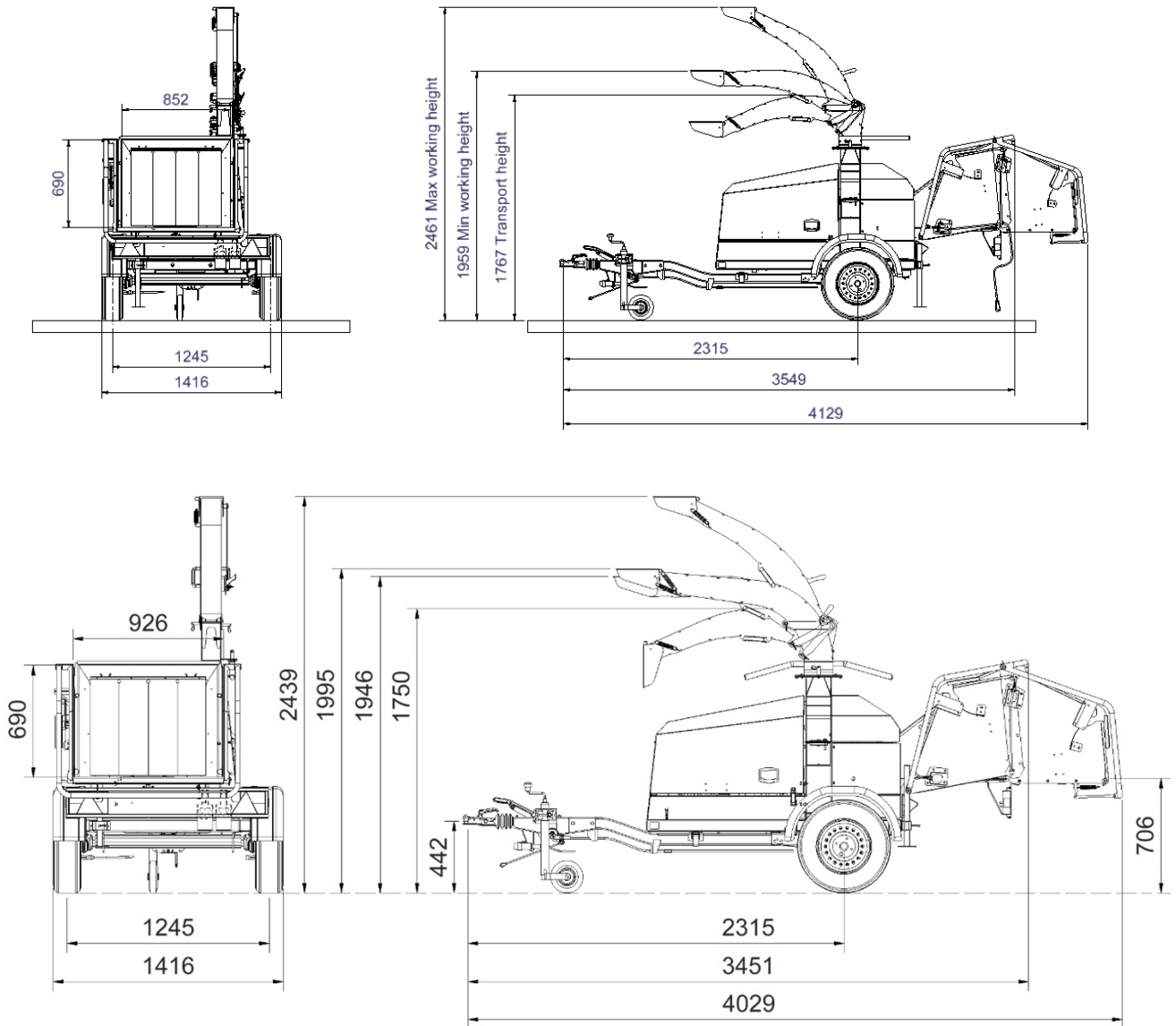

## 19 Extra equipment

### 19.1 TP CHIP KIT

The TP CHIP KIT includes sliver breakers (two or four, dependent on the model), which are fitted to the knife opening in the disc and a facing plate, which is fitted to the top in the disc housing.

The TP CHIP KIT provides significantly improved wood chip quality. If woodchip quality is not an important factor, it will be beneficial if the facing plate and the sliver breakers are removed. This will increase the capacity of the wood chipper and save fuel.

It is also recommended that the facing plate and the sliver breakers are removed when chipping wet wood with a lot of needles/leaves. This ensures good ejection.

### Replacing the facing plate

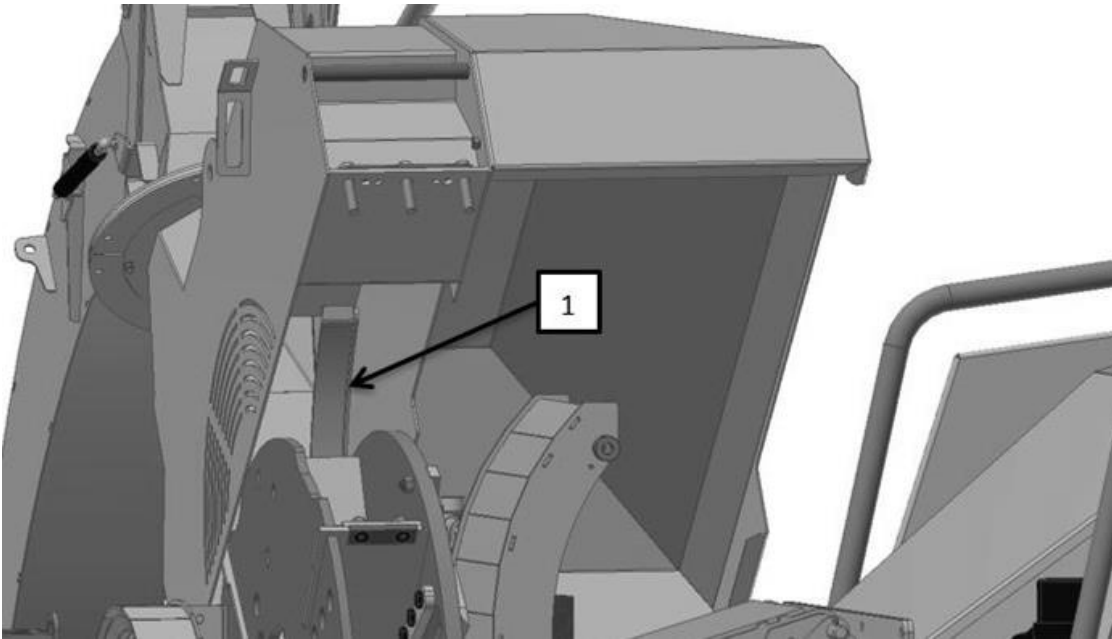

1. Open the disc housing as described in chapter 7.
2. Remove the facing plate (1), which is fitted with two M12 bolts in the side of the top disc housing.
3. Replace the facing plate (1) if it is worn.
4. Fit the new facing plate (1) and tighten using the two M12 bolts in the side of the disc housing.
5. Finally, close the disc housing as described in chapter 7.

## Replacing the sliver breakers

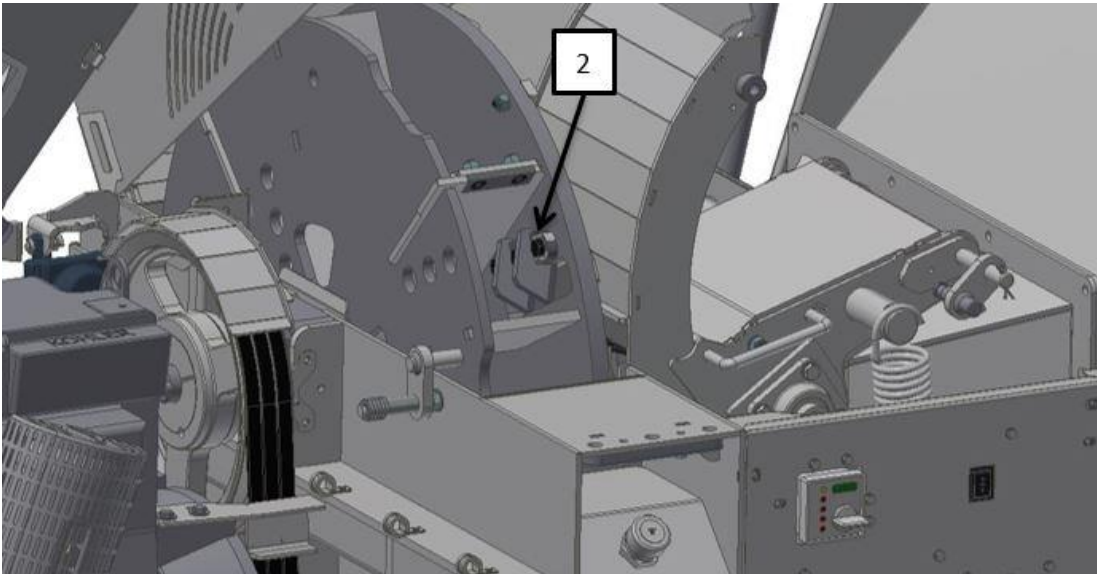

1. Open the disc housing as described in chapter 7.
2. Remove the bolts (two or three, dependent on the model), which secure the knife and clamping plate/sliver breaker (2) to the disc.
3. Replace the sliver breakers (2).
4. Carefully clean the knife, sliver breaker (2) and contact surface.
5. When fitting the sliver breaker, the bolts **must** be lightly oiled ( $\mu = 0.125$ ), i.e. light oil, WD 40 or an equivalent product. Do **not** use copper grease, MoS<sub>2</sub> or similar low friction grease.
6. Check that the distance between the knife edge and the counterknife is set correctly to **D** (see chapter 13).
7. The bolts (two or three, dependent on the model) must be tightened to **110 Nm / 11 Kpm**. Use a torque wrench to do this. (Available as extra equipment).
8. Finally, close the disc housing as described in chapter 7.

## 19.2 TP TOOLKIT

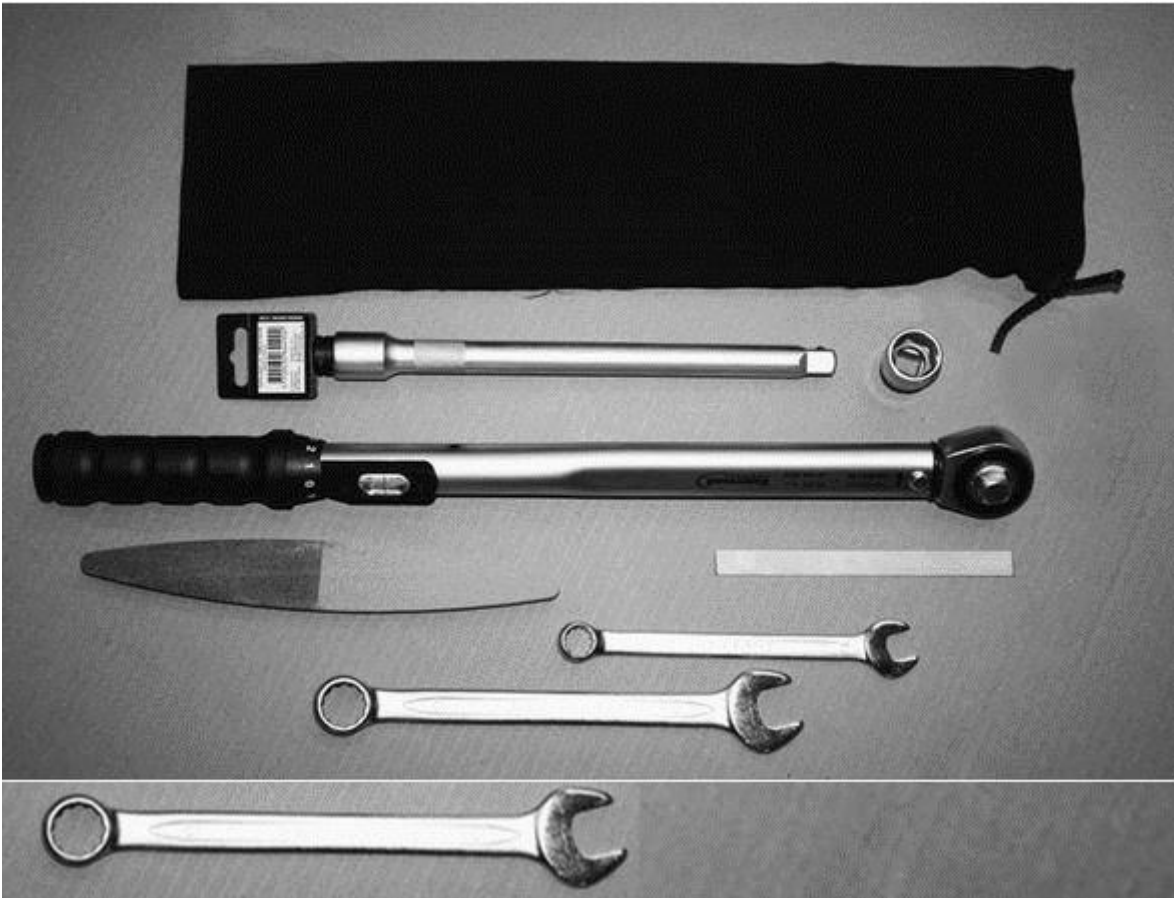

The TP TOOLKIT contains:

- Tool bag
- Combination wrench 13 mm
- Combination wrench 17 mm
- Combination wrench 19 mm
- Grinding stone "Flexovit"
- Precision feeler gauge 1.5 x 150 mm
- Torque wrench 5-30 kPm
- WBW-VLL extender 1/2" - 250 mm
- WBM TOP 1/2" - 6 KT/19 mm

### 19.3 TP SPARE WHEEL

TP SPARE WHEEL contains the spare wheel and spare wheel retainer for fitting the wheel.

#### Fitting TP SPARE WHEEL

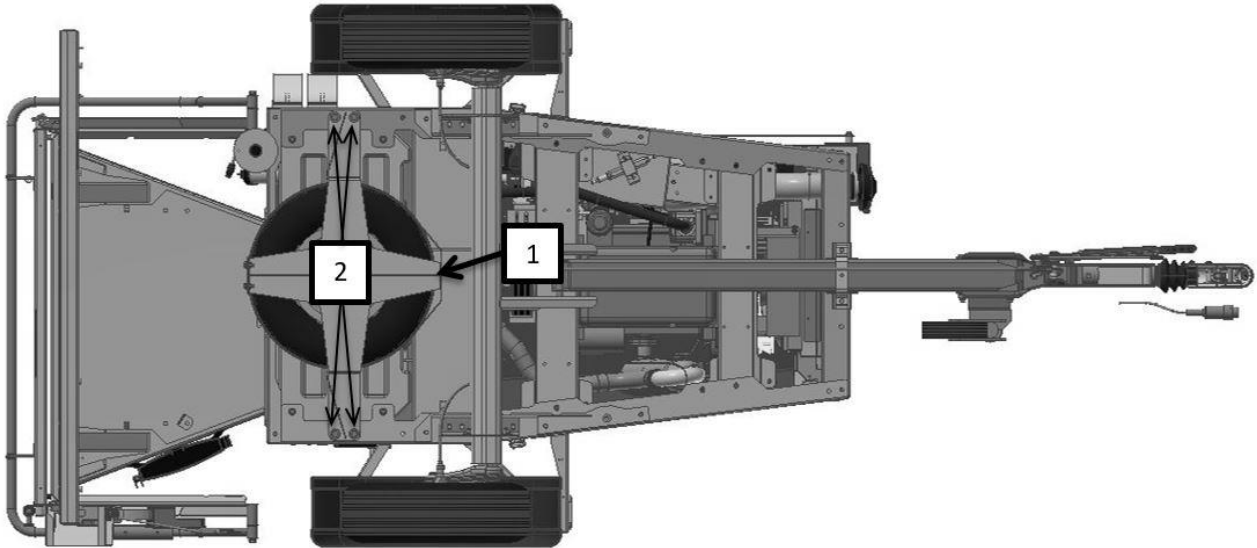

1. Ensure that the wood chipper is stabilised with the support leg and nose wheel set, so that it cannot tip over.
2. Fit the TP SPARE WHEEL (1) onto the underside of the wood chipper using four bolts (2).

#### Removing the spare wheel

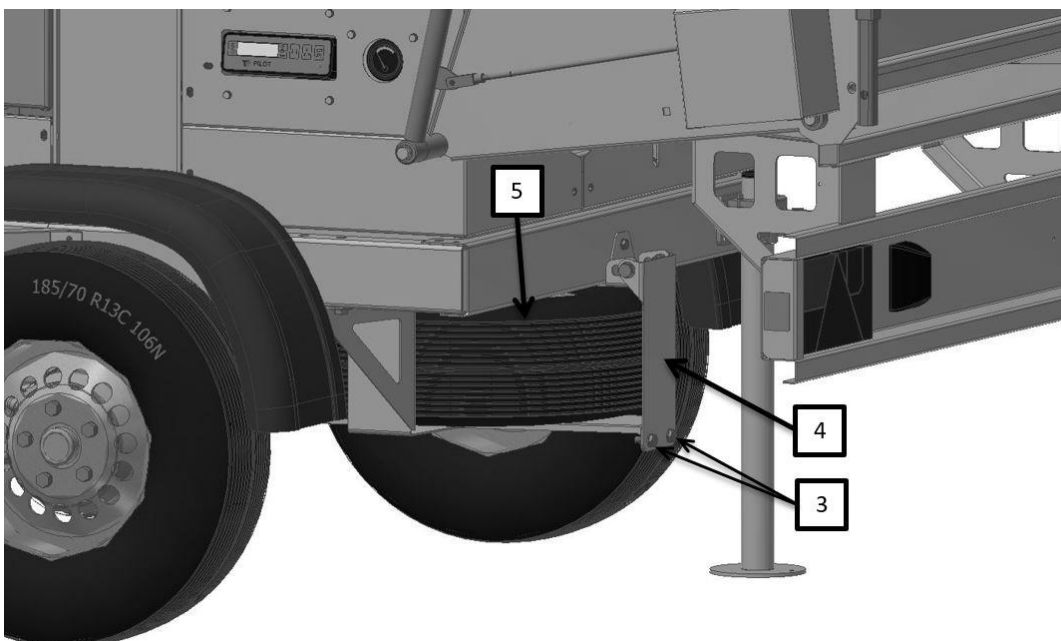

1. Ensure that the wood chipper is stabilised with the support leg and nose wheel set, so that it cannot tip over.
2. Remove the two M10 bolts (3), which hold the hatch (4). The hatch (4) can now be lifted up and pushed in, so that it is held securely in the open position.
3. Pull the wheel (5) out of the wheel carriage, so that it lands on the ground. The wheel is now ready to replace the punctured or damaged wheel on the wood chipper.

### Fitting the spare wheel in the spare wheel support

To re-fit the spare wheel, carry out the above procedure for removing it in reverse order.

### Wheel change

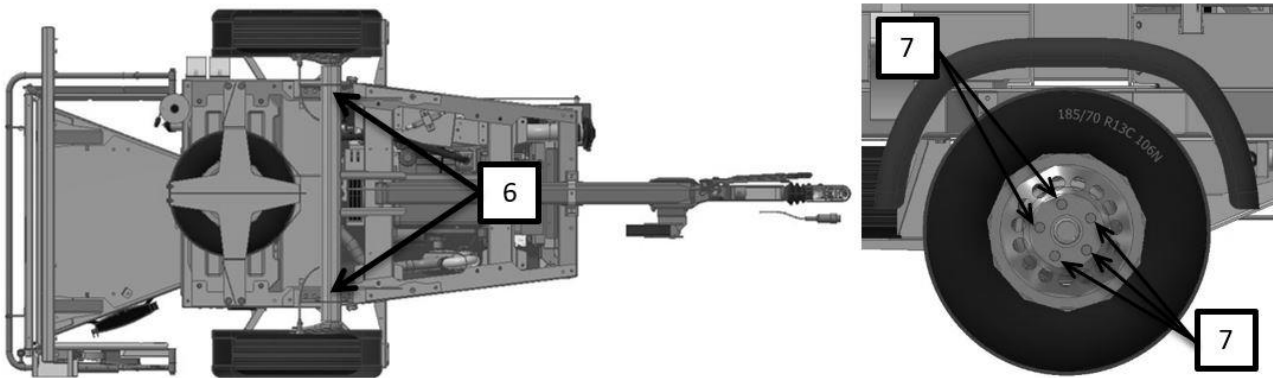

1. Use the jack to lift wood chipper using one of the two lifting points (6) depending on which wheel is to be replaced. Always put blocks against the wheel until you change the wheel!
2. Remove the wheel bolts (7) (four or five, dependent on the model), which hold the wheel securely to the wheel axle.
3. Now replace the wheel with the spare wheel and secure the spare wheel using the wheel bolts (7) (four or five, dependent on the model). Tighten the wheel bolts to 120 Nm. Use a torque wrench to do this. (Available as extra equipment).
4. Finally, fit the punctured/damaged wheel inside the spare wheel holder.

## 20 Spare Parts Catalogue