



VALIANT 600

AR RS

User and maintenance booklet

Translation of the original instructions – English -
Instructions comply with standard ISO 3600:1996



Chapter 1: Premise 3

Chapter 2: General safety regulations 11

Chapter 3: Technical data and characteristics..... 49

Chapter 4: Instruments and controls..... 65

Chapter 5: User regulations 77

Chapter 6: Periodic maintenance..... 135

Chapter 1: Premise

Contents

Section 1: Introduction and safety	4
Section 2: Tractor identification	6
Section 3: Engine identification	7
Section 4: Warranty	8
Section 5: Enclosures	9

Section 1: Introduction and safety

Note:

Carefully store this "user and maintenance booklet" and consult it regularly.

The purpose of this publication is to allow the owner and operator to use the tractor in complete safety.

The installation of the product by the dealer also ensures that these user and maintenance instructions have been understood correctly. Nevertheless, if you do not understand parts of this booklet, do not hesitate to contact our dealer since it is important that these instructions are understood and observed. Daily maintenance should be carried out regularly and the vehicle operating hours should be recorded in a register.

When replacement parts become necessary, use only original spare parts. Authorized retailers supply original spare parts and can give advice on their assembly and use. The installation of spare parts of a lower quality could cause extensive damage. The customer should therefore acquire the necessary spare parts exclusively from an authorized retailer.

Because of the considerable diversity of the conditions of use, the company cannot provide fully up-to-date and complete publications on the performance and methods of use of the vehicles it manufactures. It therefore cannot assume responsibility for loss or damages deriving from what is published or any error or omission. If the vehicle must be used in particularly heavy, abnormal conditions (e.g. in deep water or very muddy soil), we recommend contacting your retailer for special instructions to prevent annulment of the warranty.

The manufacturer of the tractor will not accept any responsibility for damage or injury due to improper use of the vehicle, any related risks being the responsibility of the user.

This machine is designed exclusively for generic agriculture works or similar. Use in any other environment is considered improper use.

Compliance with and strict observance of the conditions of use, servicing, and repair specified by the manufacturer are also an essential part of envisaged use.

To use, service and repair this tractor, all of its special characteristics and the relative safety (accident prevention) standards must be fully understood.

Customers should contact an official retailer about any servicing or tuning problems.

Since operator safety is one of the main concerns of those who design and develop new tractors, the designers try to provide as many safety devices as possible. In spite of this, each year many accidents occur which could have been avoided if the operator had been less hasty and more cautious when handling machinery and farming equipment. Read and follow the safety instructions reported in detail in this chapter of the manual carefully.

Unless otherwise indicated, the data and information contained in this manual apply to all models.

The content of this manual corresponds to the latest technical information available at the time of printing. The manufacturer reserves the right to make changes at any time without advance notice or penalty.

In addition to the present instruction booklet, each tractor is delivered with a user and maintenance manual for the engine, which is an integral part of the supplied documentation.

All rights reserved. This manual may not be reproduced or copied, fully or partially, without the written permission of BCS.

Section 2: Tractor identification

The tractor is identified by the data engraved on the identification plate on the right side of the gearbox guard. (Fig. 1.1).

To ensure prompt and efficient service, this data must be provided when ordering spare parts or requesting technical information or clarifications.

Type of tractor	
Tractor type-approval number	
Identification number	

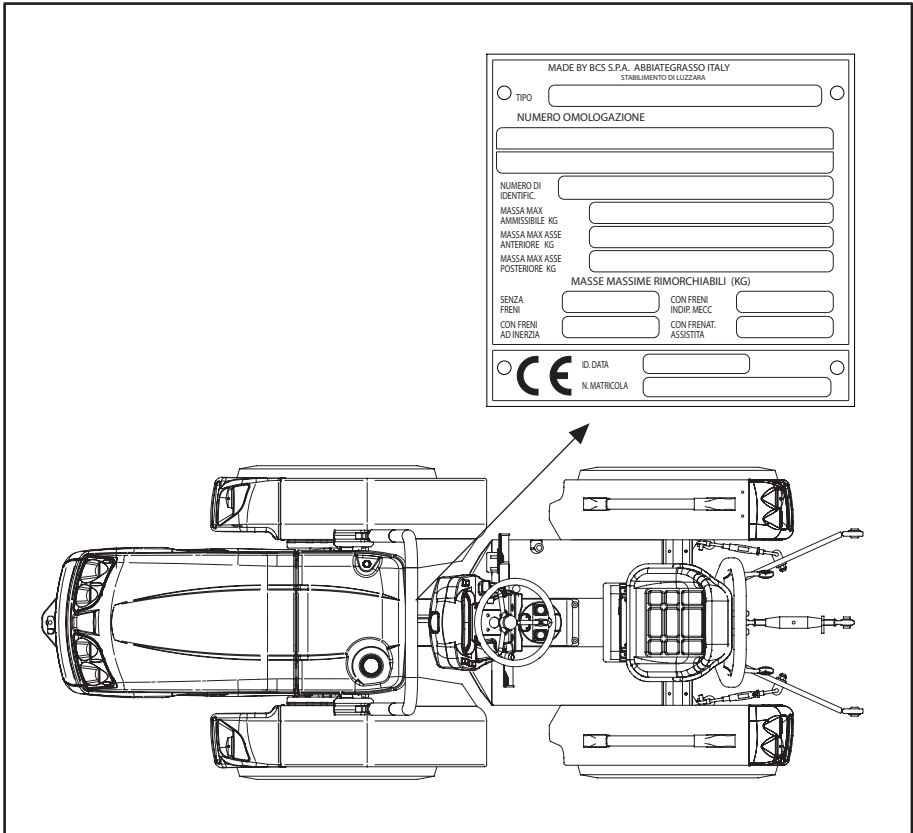

Fig. 1.1

Section 3 : Engine identification

The engine is identified by the data engraved on the identification plate located on the right side of the engine itself (Fig.1.2).

To ensure prompt and efficient service, this data must be provided when ordering spare parts or requesting technical information or clarifications.

Contact Kohler Lombardini regarding all interventions and notifications.

Engine type-approval number	
Type of engine	
Technical characteristics	

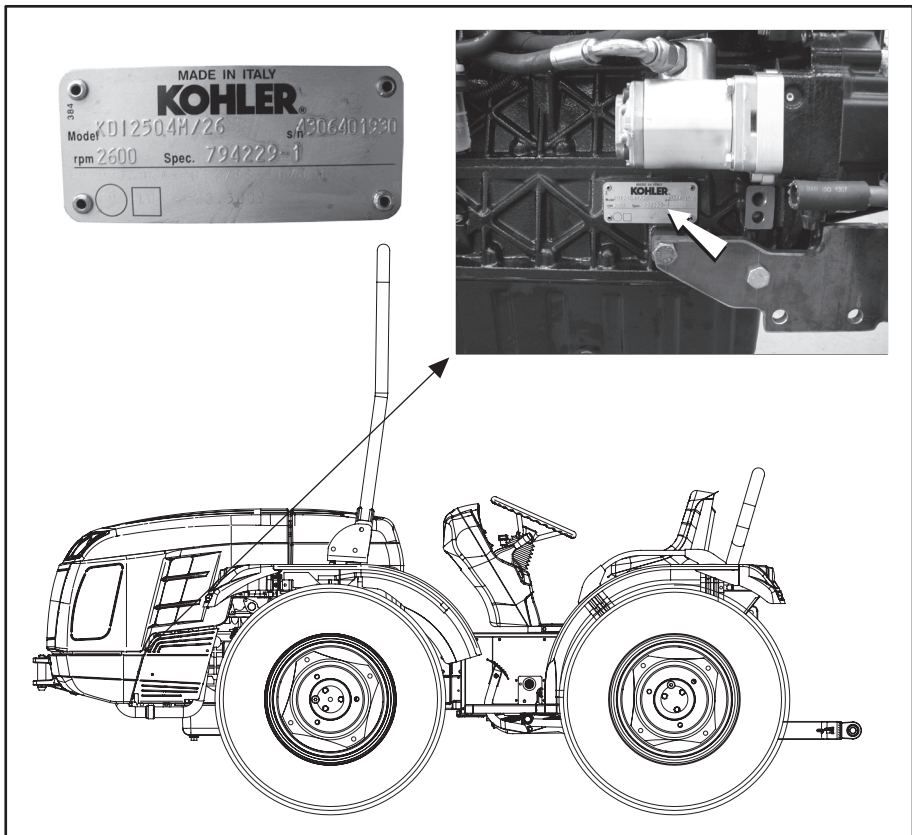

Fig. 1.2

Section 4: Warranty

Bcs products are covered by a warranty that, under certain conditions, protects against material and construction defects. This booklet is published for worldwide circulation. The precise warranty terms and conditions regarding retail sales in each country therefore cannot be precisely described in detail. Purchasers of new tractors are kindly asked to request all of the details from the retailer where the tractor was purchased.

The retailer or dealer is obliged to supply certain services when delivering a new tractor to the customer. These services include thorough preliminary testing at the time of delivery to ensure that the vehicle can be used immediately as well as an explanation of all of the instructions on the main principles of use and maintenance. These instructions regard the instruments and controls, periodic maintenance and precautionary safety measures. This training course must be provided to all people who will use and maintain the tractor.

Note:

The tractor's manufacturer does not accept any responsibility for complaints due to unapproved installation of components or hitching of implements, and unauthorized modifications and alterations.

Proper installation and regular maintenance are very helpful in preventing breakdowns. If, nevertheless, operation problems occur during the period of validity of the warranty, the following procedure should be used:

- Notify the retailer from whom the tractor was purchased immediately, indicating the model and serial number. It is very important that this is done right away since the warranty will not be valid if the anomaly is not

resolved promptly, even if the original breakdown was covered;

- Provide your retailer with as much information as possible. The retailer will therefore know the number of operating hours, the type of work being carried out and the symptoms of the problem. Remember that normal maintenance operations such as tune-ups and brake/clutch adjustment, as well as the supply of materials used for servicing (oil, filters, fuel and antifreeze) are not covered by the warranty.

Note:

The installation of non-original parts could mean using a spare part of lower quality. The tractor manufacturer does not assume any responsibility for any loss or damage deriving from the installation of these parts. The manufacturer warranty will be annulled if they are installed during the period of validity of the warranty.

During the period of validity of the warranty, all repairs and maintenance should be carried out by the retailer so that the operation and performance of your new tractor may be monitored carefully.

For optimum performance of your tractor, never skip regular maintenance checks or servicing, even after the warranty has expired. Contact your retailer for all of the main servicing operations: a specialized technician will take stock of the situation between one intervention and another.

The mechanics are regularly informed and updated about the product, servicing techniques and the use of modern diagnostic instruments and equipment. They regularly receive bulletins on servicing, possess all shop manuals and all other technical information necessary for ensuring that repairs and servicing are

up to standard.

Note:
Panels and guards have been removed in some of the illustrations in this operator instruction booklet for greater clarity. Never run the tractor without reassembling these components. If a panel or guard must be removed to carry out repairs, it will need to be reassembled before using the tractor.

Section 5 : Enclosures

In addition to this User Maintenance Manual, the tractor is supplied as standard with:

- Engine use and maintenance manual;
- Service booklet.

Chapter 2: General safety regulations

Contents

Section 1: Terms and abbreviations	13
Section 2: Alert and safety words and symbols	13
Section 3: Safety - Tractor and implement	14
Section 4: Safety - Introduction	14
Section 5: Safety - Recommendations for the operator	15
Section 6: Safety - Decals	15
Section 7: Safety - Following a safety plan	16
Section 8 : Rollbar	17
Section 9: Precautions for operating safely	19
Section 10: Checking the equipment	22
Section 11: Cleaning the tractor.....	24
Section 12: Protecting the environment	24
Section 13: Safety - Tractor maintenance	25
Section 14: Safety - Startup	26
14.1 Getting on and off of the tractor safely	26
14.2 Safe startup	27
Section 15 : Working safely.....	28
Section 16 : Carrying out the right maneuvers.....	28
Section 17 : Operating safely	29
Section 18 : Paying attention to others.....	30
Section 19 : Risk of overturning	31
Section 20 : Preventing lateral overturning	32
Section 21 : Preventing backward overturning.....	34
Section 22 : Risky operations.....	36
Section 23 : Implements and hitches	38
Section 24 : Driving on roads.....	39
Section 25 : Rules of the road.....	40
Section 26 : Safety - After use	41
Section 27 : Personal protection equipment against noise	41
Section 28 : Position of safety decals.....	42
28.1 58074880	42
28.2 580A1016	42
28.3 580A1607	43
28.4 580A1606	43
28.5 580A1605	43
28.6 58076077	44
28.7 580A1608	44

28.8 580A1037 44
28.9 580A1039 45
28.10 580A1038 45
28.11 AR model tractor 46
28.12 RS model tractor 46
Section 29: Using the loaders 47
Section 30: Forestal use 47
Section 31: Using the sprayers 48

Section 1: Terms and abbreviations

Transporter: person chosen and authorized, being in possession of the qualifications and skills required to load, unload and move the machine from the means of transport.

Driver: person chosen and authorized, being in possession of the qualifications and skills required to drive, use and service the vehicle.

RS tractor: tractor with steering wheels.

AR tractor: articulated tractor

Section 2: Alert and safety words and symbols

In the present instruction booklet there are warnings about tractor safety and damage. Observe these warnings carefully in order to prevent the risk of injury and damage. The types of warnings and how they appear and are used in this instructions booklet are described as follows:

 **Danger:**

This symbol and the word DANGER warn of an imminent hazard that could endanger the operator or other directly involved persons.

 **Warning:**

This symbol and the word WARNING indicate a potentially dangerous situation for the machine, which could also compromise the operator's safety.

 **Caution:**

This symbol and the word CAUTION warn the operator that he could risk damaging the machine unless he complies with a certain procedure.

Note:

Underscores and informs the operator about the correct technique or procedure required.

Section 3: Safety - Tractor and implement

- The tractor is a source of mechanical and hydraulic power.
- When the tractor is used together with an implement or other equipment, it becomes a work unit.
- This instruction booklet has been compiled to illustrate the safety regulations associated with normal use of the tractor.
- This booklet does not cover all of the user and safety instructions for all of the implements and hitches that may be installed when the tractor is delivered or at any time in the future.
- **It is essential that the operator carefully follows the instructions contained in the manual relating to this machinery, both installed and towing and for the trailer.**
- **NEVER combine the tractor-machine or tractor-trailer unless you have carefully read the instructions for this equipment.**

Section 4: Safety - Introduction

This chapter of your operator instruction booklet on safety intends to outline some of the most common safety situations that can occur during normal use and maintenance of your tractor and to suggest possible ways of behaving in these situations. This chapter is NOT a substitute for other safety regulations in other chapters of this manual.

Additional precautions may be necessary depending on the implements used and the work conditions on the field or in areas of maintenance and repair. The tractor manufacturer does not have direct control over applications, operations, inspection, lubrication or maintenance of the tractor. It is therefore YOUR responsibility to practice good rules of safety in these areas, using common sense as well.

Section 5: Safety - Recommendations for the operator

It is **YOUR** responsibility to read and understand the chapter on safety contained in this booklet before using the tractor. You will need to follow these safety regulations and use them throughout the working day.

While reading this chapter you will notice that illustrations are used to better explain certain situations.

Always remember that **YOU** alone are responsible for your safety. Good safety regulations protect you as well as those around you. Study the characteristics shown in this manual thoroughly and make them an important part of your safety plan.

Always remember that this chapter has been written exclusively for this type of vehicle. Apply all other normal and regular precautions that ensure operating safety and especially **REMEMBER THAT SAFETY IS YOUR RESPONSIBILITY AND YOU CAN PREVENT SERIOUS AND EVEN FATAL ACCIDENTS.**

Every time you see the words and symbol indicated below, used in the present manual and on decals, you **MUST** take note of the instructions given because they refer to personal safety.

 Warning:

The symbol and word **WARNING** indicate a potentially dangerous situation. If the instructions or procedures are not carried out correctly, they can lead to personal injury or the loss of life.

Section 6: Safety - Decals

 Warning:

Do not remove or make the Danger, Warning, Caution or Instruction decals illegible.

Replace every Danger, Warning, Caution and Instruction decal that is not legible or that has been lost. New decals are available at your dealer if lost or damaged. The exact position of the decals on the tractor is indicated at the end of this chapter.

If a used tractor is purchased, refer to the figure at the end of this chapter to make sure that all of the safety decals are in the correct position and are legible.

Section 7: Safety - Following a safety plan

To use a farming tractor safely, operators must be qualified and authorized. To be qualified, an instructional course and training must be taken at the place of work, the safety regulations and work regulations must be known and the instructions contained in this operator instruction booklet must be understood.

For example, some regulations specify that no one under the age of 18 years (European regulations) can use motorized machinery: this includes tractors. You are responsible for knowing these regulations and observing them in the area or situation in which they are used.

These include, but are not limited to, the instructions below for using the tractor safely.

 **Warning:**

The operator must not use alcohol or drugs that can change or alter his or her state of alertness and coordination. An operator taking medication or monitored for drug use needs medical authorization stating whether or not he or she is able to use the tractor safely.

Observe the following precautions:

- NEVER let children or young adults or unqualified personnel use your tractor. Keep others far away from your working area.
- Fasten the safety belts when the tractor is equipped with a vertical rollbar.
- When possible, avoid operating the tractor near ditches, excavations and holes. Reduce the speed when turning, going over slopes or passing over bumpy, slippery or muddy surfaces.
- Stay away from steep slopes to operate safely.
- Watch where you are going, especially

at the end of the field, on roads and around trees.

- Do NOT let anyone get on the tractor or the implement unless an approved passenger seat has been installed.
- Tow only with the drawbar or from its points and never above the center line of the rear axle.
- Operate the tractor calmly without sudden turns, starts or stops. When the tractor is parked, engage the parking brake.
- Never modify or remove any part of the equipment or use implements not envisaged for your tractor.

Section 8 : Rollbar

The safety frame reduces the risk of injury should the tractor tip over.

Always operate with the safety frame in the upright position and the safety belts securely fastened.

Before using the tractor, make sure that the safety frame has not been damaged and that it is securely fastened to the tractor.

The operator must use safety belts in all work conditions, on the field as well as when driving on roads.

The safety belt must be worn and adjusted snugly against the body and must not be twisted.

The safety belt must be replaced if it has been strongly stressed, e.g. by a tractor overturning, or when it shows wear and tear, cuts or any visible signs of overload.

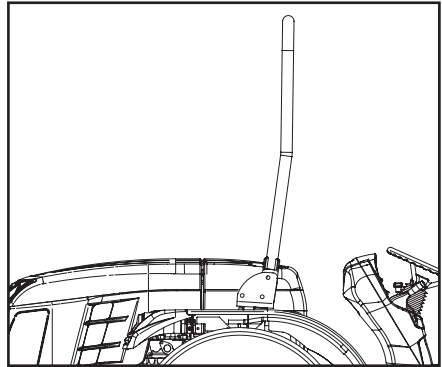

Fig. 2.1

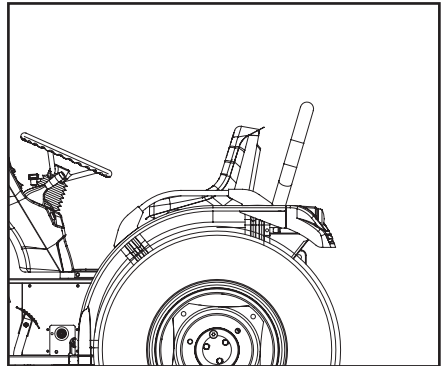

Fig. 2.2

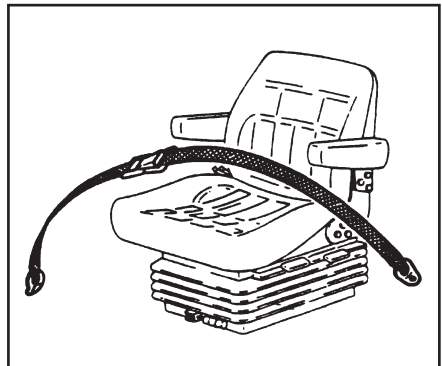

Fig. 2.3

Use:

- DO NOT ATTACH chains, cables, etc. to the rollbar for towing; they could cause the tractor to tip over: always tow from the drawbar.

If the tractor has rolled over or the rollbar has been damaged (for example, because it hit a suspended object during transport) it must be replaced to guarantee original levels of safety.

After an accident, check the rollbar, the operator seat, the safety belts and their anchoring points. Before using the tractor, replace all damaged parts.

DO NOT WELD, DRILL, BEND OR STRAIGHTEN THE ROLLBAR: these operations reduce the guaranteed level of the protection.

Section 9: Precautions for operating safely

Protect yourselves.

Wear all of the protective clothing (Fig. 2.4) and devices for personal safety made available and necessary for work.

Do not take risks.

You will need the following protective clothing:

- A protective helmet.
- Goggles or a protective mask.
- Earmuffs protect the ears.
- A protective mask or filter for breathing.
- Clothing for bad weather.
- Reflective clothes.
- Heavy work gloves (Neoprene for using chemical products, leather for heavy-duty work).
- Accident prevention protective shoes..

DO NOT wear loose clothing, jewelry or similar items and tie long hair back, as it could get caught on the controls or other parts of the tractor.

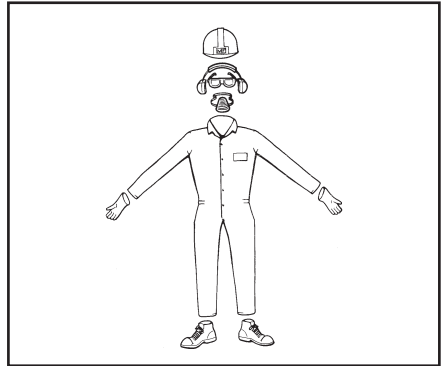

Fig. 2.4

Locate the position of the extinguishers and the first aid kit (Fig. 2.5) or the emergency equipment and identify how to call for help quickly. Make sure that you know how to use this equipment.

You must be familiar with your tractor.

Learn about the characteristics of your tractor. Learn how to use all of the equipment on your vehicle and the implements and hitches used on it. Learn how to use each control, indicator and instrument and their functions. You will need to know the rated load capacity, the speed range, the characteristics of the brakes and the steering system, the turning radius and necessary space of use.

Always bear in mind that rain, snow, ice, gravel and loose soil can change tractor handling. In difficult conditions, slow down and be more prudent and careful.

Study the DANGER, WARNING and CAUTION signs on you tractor and all of the reported information.

BEFORE STARTING THE ENGINE, READ THIS OPERATOR INSTRUCTION BOOKLET (Fig. 2.6).

STUDY THIS BOOKLET BEFORE BEGINNING WORK (Fig. 2.6).

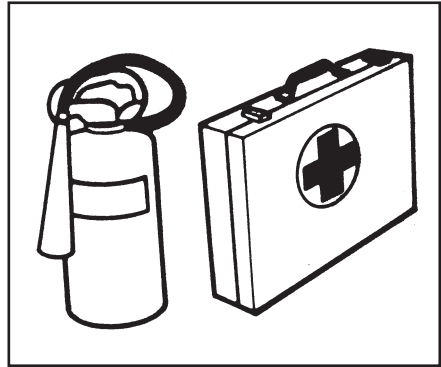

Fig. 2.5

IF YOU DO NOT UNDERSTAND SOMETHING IN THIS MANUAL, ASK SOMEONE (for example your dealer) TO EXPLAIN IT TO YOU

Always use all of the available protection and safety systems.

Keep all protective devices in their places and safely secured. Make sure that all of the guards, protective shields and safety signs are correctly installed as specified and are in good condition.

To guarantee your safety and that of others, your tractor must be equipped with:

- A rollbar, which must always be mounted in the protective position (Fig. 2.1). Safety belts should be used in accordance with current laws in the various markets.
- Protective shields of the PTO.
- Rearview mirrors.
- An extinguisher with characteristics that correspond to the legislative requirements in force in the various markets.
- A rollbar with a structure that protects against falling objects or with canopies (if installed). Remember that the safety rollbars of these shields do not protect against large falling objects such as large round bales or parts of fences.
- Slow moving vehicle (SMV) symbol.

Learn which devices are necessary for operating safely and always use them. Make sure that they are in their place and in good condition. NEVER remove them or disconnect them.



Fig. 2.6

Section 10: Checking the equipment

Before starting your working day, check the tractor and make sure that all of the systems are working properly.

- Do NOT smoke during refueling. Do not use open flames. (Fig. 2.7).
- Make sure that there are no loose, broken, lost or damaged parts. Carry out proper repairs as necessary. Make sure that all of the safety devices are in their place.
- Make sure that the rollbar and safety belts are not damaged (a damaged rollbar or safety belt MUST be replaced).
- Make sure that the implements and attachments are installed correctly and that the tractor and the implements connected to the PTO have the correct speed ratios (rpm).
- Make sure that the tires do not have cuts or bulges and that the pressure is correct. Replace worn and damaged tires. Make sure that the brake pedals and the parking brake function correctly. If necessary, adjust them.
- Stop the engine and wait for it to cool before refueling.
- Check the engine oil level and top off, if necessary.
- Carry out all of the maintenance and adjustment operations indicated in the relative chapter of this manual.
- Verify that the safety hitching systems of the PTO are connected.
- Verify that the power take-off and the drive shaft guards are in position and function correctly.

- Check the tractor hydraulic systems and the connected implements. Repair or replace any damaged or leaking parts.
- Check the engine cooling circuit and add coolant, if necessary.



Fig. 2.7

 **Warning:**

Pressurized fuel or hydraulic fluids can penetrate the skin and eyes and cause serious injury, blindness or death. Leaking pressurized fluids may not be visible. Use a piece of cardboard or wood to find leaks. Never use bare hands. Always wear goggles to protect eyes. If, for any reason, a fluid penetrates the skin, it **MUST** be surgically removed within a few hours by a doctor who specializes in these types of accidents.

Before pressurizing a fuel injection system or a hydraulic system, make sure that all of the connections have been tightened and that the lines, pipes and hoses are not damaged. Before disconnecting the hydraulic or fuel pipes, make sure that the circuit is not pressurized.

Make sure that all of the hydraulic lines are correctly installed and are not tangled.

 **Warning:**

The cooling circuits are pressurized when the engine is hot. Before removing the radiator cap, stop the engine and let it cool.

Section 11: Cleaning the tractor

- Keep the work surfaces and engine compartments clean.
- Before cleaning the vehicle, always lower the implement onto the ground, place the gear levers in neutral, engage the parking brake, turn off the engine and remove the key.
- Clean the footboards, steps and pedals. Remove grease and oil. Eliminate dust and mud. Remove ice and snow. Remember that slippery surfaces are dangerous.
- To clean plastic parts such as the console instrument panel and the indicators, avoid using gasoline, paraffin, paint solvents, etc.
To clean these parts of the tractor, use water, neutral soap and a soft cloth **ONLY**.
The use of gasoline, paraffin, paint thinners, etc. causes discoloration, cracking, and deformation of the cleaned parts.
- Remove implements, wrenches, hooks etc. and put them back where they belong.
- If using a self-propelled sprayer, never stand too near the tractor and avoid directing jets of water on the ignition panel, electrical components, electric-hydraulic controls and adhesives.

Section 12: Protecting the environment

- Polluting canals, waterways and the ground is illegal. Use authorized dumping facilities, including municipal zones and garages that have containers for disposing of used oil. If in doubt, contact local authorities for information.
- To understand the correct methods for disposing of oil, filters, tires, etc., contact your local differentiated waste collection center or your dealer.
- **Scrapping the tractor:** the tractor is composed of parts that are subject to disposal regulations and standards. Therefore, when the tractor is discarded and no longer used, it must be scrapped by authorized agencies **Do not dispose of the tractor or its components in the environment.**

Section 13: Safety - Tractor maintenance

- Do NOT carry out maintenance (Fig. 2.8) on the tractor while the engine is running or hot or while the tractor is moving.
- Before carrying out adjustments or maintenance on the electrical system, disconnect the battery cables, starting with the negative cable (-).
- To prevent fire and explosion, do not use open flames near the battery or cold start devices. To avoid creating sparks and possible consequent explosions, use jumper cables according to the instructions.
- When making repairs or adjustments, contact your local dealer and have specialized personnel carry out the work.
- The implements and/or the tractor must be supported with wooden blocks or suitable supports, NOT with hydraulic jacks.
- Periodically check the tightness of all of the nuts and bolts; especially the bolts of the wheel hubs, disks and rims. Tighten to the specified tightening torque.
- Regularly check the power steering tank and top off with approved oil, if necessary.
- Regularly check the brakes and, if necessary, top off the tank and/or adjust them. Make sure that the brakes are correctly adjusted, especially when towing trailers.



Fig. 2.8

Section 14: Safety - Startup

Before starting the engine, walk around the tractor and the mounted implements. Make sure that no one is under, above or near them. Notify other workers or people present that the tractor will be started and do not start it until they have moved to a safe distance from the tractor, implement or trailer.

Make sure that all present, **especially children**, are in a safe place before starting the engine.

14.1 Getting on and off of the tractor safely

When getting on the tractor, face and use the three points of contact. (Three points of contact means both hands and one foot or one hand and both feet in contact with the tractor at all times when getting on or off of it).

Clean shoes and dry hands before getting on. Use the points of support, handles, steps or rungs (if provided) when getting on and off.

NEVER use the control levers as handles or rest feet on the control pedals when getting on and off.

NEVER attempt to get on or off of the tractor while it is moving. NEVER jump down from the tractor at any time.

Warning:

Before starting the engine, make sure that there is sufficient ventilation. Never start the engine in closed environments. The exhaust gases can cause asphyxia (Fig. 2.9).

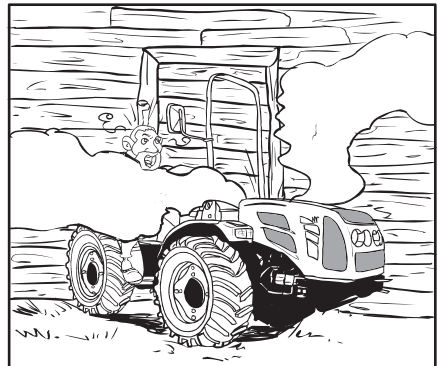

Fig. 2.9

14.2 Safe startup

Always start the engine from the operator position with all of the gear levers and the PTO lever in neutral.

Make sure that the brakes are correctly adjusted and simultaneously engaged.

Adjust the seat, fasten the seat belts (where applicable, according to regulations in force in your country), and place all of the controls in neutral before starting the tractor.

⚠ Warning:

Before starting, always make sure that people and obstacles are not present within the tractor's radius of action (Fig. 2.10).

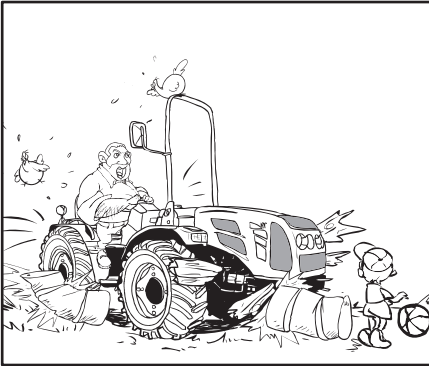

Fig. 2.10

Carry out the starting procedures described in chapter 5 - User Regulations of this instruction booklet; these include normal starting and starting in cold climates.

⚠ Warning:

Start the engine using the ignition key from the operator seat only. Never attempt to start the engine by creating a bridge between the starter terminals. The tractor could start with an engaged gear if the safety ignition circuit is bypassed in neutral. This could cause serious injury or death to people that are near the tractor.

After starting, check all of the instruments and lights. Make sure that they all function correctly. If the tractor does not respond correctly to the controls, do NOT use the vehicle until the breakdown has been resolved.

Section 15 : Working safely

 Warning:

An unbalanced tractor could tip over and cause serious injury or death. The weights of the wheels and the ballasts must be used as recommended by the manufacturer. NEVER add additional weight to compensate for overloading; reduce the load instead.

 Warning:

When using the tractor, always remain inside the operator compartment without extending any part of the body outside of it.

Section 16 : Carrying out the right maneuvers

Make sure that the tractor is ready for the type of work that must be carried out. Know the rated load capacities and never exceed them. Make sure that NONE of the implements or pieces of equipment that must be used exceeds the load capacity of your tractor. Check the output shaft/implement coupling.

Bear in mind that the tractor normally operates on bumpy, often uneven or sloping surfaces and not on paved roads. The operating conditions could reduce the maximum load permitted for transport or towing.

Section 17 : Operating safely

- Activate the controls without sudden movements. Do not make sudden turns or abruptly use other controls.
- NEVER attempt to get on or off of the tractor while it is moving. Hold the steering wheel firmly at all times with the fingers far from the spokes of the wheel itself when driving.
- Make sure that there is enough space in all directions for the tractor, rollbar and the implement.
- Do NOT use the tractor or the implements irresponsibly and do not joke around with them.
- NEVER use the controls while not seated in the operator position.
- Before getting off of the tractor, always disengage the power take-off, lower the hitches and implements to the ground, place the gearbox in neutral, engage the parking brake, turn off the engine and remove the key.

Do NOT touch, rest on or attempt to reach other components using the mechanisms of implements or allow others to do so.

Be very careful. If something breaks, comes loose or is not functioning, stop work, turn off the engine, check the vehicle and repair or make adjustments before starting work again.

Before starting the tractor, make sure that you have safe control of the speed and direction controls.

- Before starting work, inspect the area where work will be done to determine the best and safest work procedure. Plan work so that the tractor can be driven straight and forward, where possible. Pay attention to ditches, holes front and side dips, slopes, trunks and logs, still water, etc. Check for all conditions that could be a hazard. If you are using a front lift or foldable implements

or raised components, make sure that nothing blocks their passage.

Warning:

Contact with high-voltage lines can cause death. In the case of contact with voltage conductors, do NOT get off of the tractor, but rather move the tractor and/or the lift to eliminate contact and reach a safe distance (Fig. 2.11).

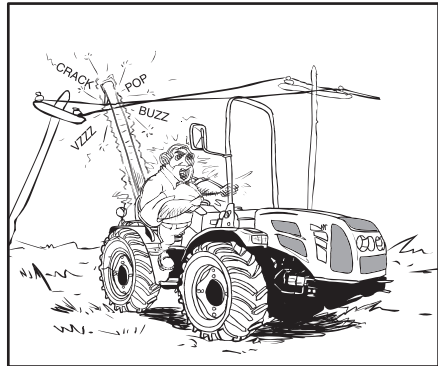

Fig. 2.11

Section 18 : Paying attention to others

- Be aware of the maneuvers you are going to carry out. Never let unqualified or insufficiently trained people operate your tractor. They can be a risk to themselves and others.

⚠ Warning:

Your tractor is designed to be used by one person only. Do NOT allow others to get on the tractor or the implements (Fig. 2.12). Do not allow anyone to climb onto the implements or other equipment, including trailers, except on certain harvesting implements where it is specifically provided for, but only during actual harvesting (not during transport). This equipment must have instructions that define the area that can be safely climbed onto. Do NOT allow children to get on the tractor.

⚠ Warning:

Make sure that the speed and direction is safely under control before moving the tractor. Move slowly until you are sure that everything is functioning normally. After starting, recheck turning to the right and left. Make sure that the steering and the braking system function. If the differential lock is engaged, do NOT operate at high speeds or change direction until it is disengaged.

⚠ Warning:

NEVER raise a load above someone.

- Keep others far away from your area of maneuver. Do not let anyone stand or pass under a raised implement.
- Do NOT lift objects that are not perfectly housed in the bucket; use the appropriate hitch. Do not let anyone stand on the rollbar or fenders.

- When using a loader, avoid sudden starts, stops, and turns and sharply reversing direction. Keep the loads as close to the ground as possible during transport.
- Never stand (or let others stand) in front of, underneath or behind equipment that will be loaded or under a load. Never drive the tractor toward someone that is near a wall or fixed object.
- Keep others away from the cardan joints, drawbars or lift beams, power take-off shafts, cylinder transmission belts, pulleys and other moving parts. Keep the protective shields installed in their places.

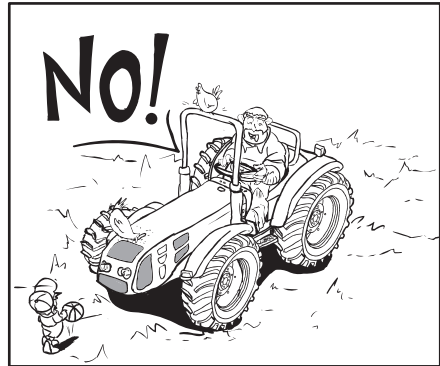

Fig. 2.12

Section 19 : Risk of overturning

If a tractor overturns, hold on tightly to the steering wheel and do NOT attempt to leave the seat until the tractor has come to a stop.

Section 20 : Preventing lateral overturning

- Adjust the wheel tract to the widest position suitable for the type of work to be carried out.
- Lock the brake pedals together before driving on roads at transportation speed.
- Reduce the speed according to the conditions of use. If the tractor is equipped with a front loader, keep the bucket and the load as low as possible.
- Make wide turns slowly.
Do NOT let the tractor bounce on bumpy ground. You could lose control.
- Do NOT tow a load that is too heavy for your tractor. You could lose control of it on a steep hill or the tractor could rear up and rotate onto the towed load, "jack knifing".
- Do NOT brake suddenly. Always brake gently and gradually.
- When going downhill, use the engine brake and the same gear as you would for going uphill. Insert the appropriate gear before starting downhill.

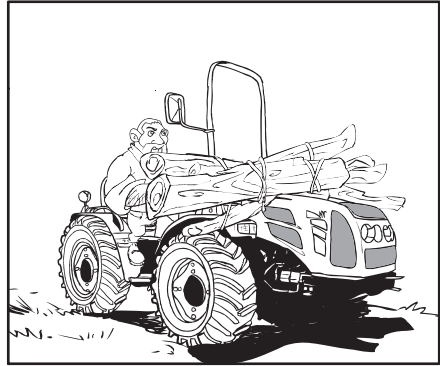

Fig. 2.13

Warning:

NEVER disengage the clutch or attempt to change gears after starting a descent.

- It is always better to drive vertically when going up or downhill, rather than longitudinally.
- Do not overload a front implement or a trailer. Use suitable counterweights to maintain tractor stability (Fig. 2.13).
- When towing a load at transportation speed, lock the drawbar at the center position and use a safety chain.
- NEVER use the tractor for rounding up animals or herds.

- If operating near ditches or banks, keep the tractor behind the fracture line. Avoid ditches, embankments, banks and edges of rivers which could cave in (Fig. 2.14).
- If a steep slope must be passed over, avoid steering toward the incline, slow down and steer clear. Always travel the slope directly uphill or downhill and never longitudinally. When going up or down a slope, keep the heavy part of the tractor and the implement facing uphill.
- If you travel over a hill with side implements installed, keep the implements on the side of the incline. Do not raise the implements. Keep them as low as possible and near to the ground when going over a slope.
- If possible, avoid going uphill or over steep slopes. If you must do so, avoid holes or depressions on the downhill side. Avoid projections, trunks, rocks or raised areas on the uphill side.

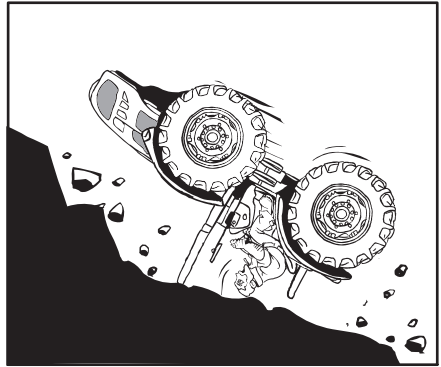

Fig. 2.14

Section 21 : Preventing backward overturning

Warning:

Towing from the rear axle or any other point above the drawbar can cause the tractor to overturn backwards.

- Do NOT tow anything from the three-point hitch or any other point above the longitudinal axis of the rear axle. Always use an approved drawbar exclusively with a pin installed in the correct position.
- High hitching points for towing can cause the tractor to overturn backwards and cause serious injury or death. Tow loads from the drawbar only.
- When using the three-point hitch for towing, the top links must be installed and kept lowered.
- Use front ballasts to increase tractor stability when towing a heavy load or to counterbalance a heavy implement installed on the rear.
- Do NOT overload and do NOT ballast beyond the load capacity of your tractor. Never add ballasts to compensate for overloading. Reduce the load (Fig. 2.15).

Warning:

Overloading is ALWAYS dangerous. Verify the rated load capacities of your tractor and NEVER exceed them.

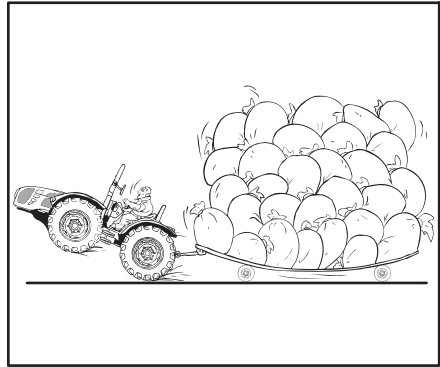

Fig. 2.15

- Start slowly and gradually increase the speed. Do NOT increase the engine rpm or lower the clutch. If the tractor is hitched to a heavy load or an unmovable object, improper use of the clutch could cause overturning.
- If the front of the tractor begins to rear up, disengage the clutch immediately.
- If the tractor is mired in mud or stuck in the ground, do NOT attempt to exit by driving forward. The tractor could rotate on its rear tires and overturn (Fig. 2.16). Lift or remove the installed implements and try to **MOVE IN REVERSE**. If this is not possible, tow the tractor out with another vehicle.
- If it is stuck in a ditch, try to **BACK OUT**, if possible. If you must go forward, do so slowly and carefully.
- A tractor with or without an implement hitched onto the rear must move in reverse when going uphill and move forward when going down a slope.
- A tractor with a front load must be driven in reverse when going downhill and forward when going uphill. Keep the bucket of the loader as low as possible.
- Always keep the tractor in gear when going downhill. Never let the tractor go downhill with the clutch disengaged or the transmission in neutral.

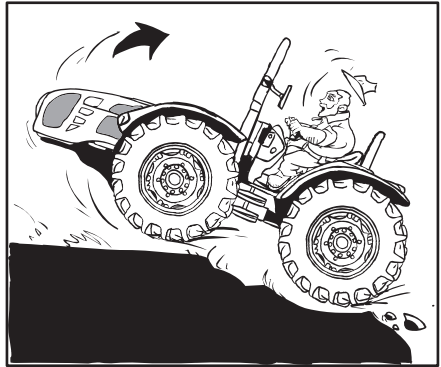

Fig. 2.16

Section 22 : Risky operations

- Make sure that the power take-off (110) guard is in position and that the shaft's cap (111) is on when the power take-off is not used.
- Before connecting, disconnecting, cleaning or adjusting towed implements from the power take-off, turn off the engine, remove the key and make sure that the power take-off's shaft is locked in place (Fig. 2.18).
- Make sure that all of the power take-off shaft safety devices are installed and observe the instructions on the safety decals.
- Make sure that everyone is away from the tractor before engaging the power take-off. During stationary use of the tractor, always place the gearbox in the neutral, engage the parking brake and block the wheels of the tractor and the implement with wooden wedges or wheel clamps.
- When working with implements connected to the power take-off, never leave the operator seat until the power take-off has been disengaged, the transmission placed in neutral, the parking brake engaged, the engine off and the ignition key removed.
- Do NOT use adaptors, reducers or extensions that can lengthen the coupling shaft of the power take-off or the cardan joint beyond the protection offered by the power take-off protective shield.
- The top link of the three-point hitch and the vertical tie rods of the three-point hitch must not be extended beyond the point where the thread begins to appear.

Warning:

NEVER attempt to unscrew the hydraulic connections or adjust an implement while the engine is running or the power take-off shaft is moving. This creates a dangerous situation with the risk of serious injury or death (Fig. 2.19).

- When using chemical products, follow the instructions for use, storage and disposal carefully. Furthermore, follow the instructions of the manufacturers of the equipment for using chemical products.
- When working under conditions of poor visibility or in the dark, turn on the working lights and reduce the speed.
- Work with the wheel track in the widest position possible for the type of work that is being carried out. To adjust the wheel track, refer to the paragraph in chapter 5 - User Regulations.
- Reduce the speed when working on bumpy ground or slippery surfaces or when leaves and the foliage of trees reduce visibility.
- Do NOT make sharp turns at high speeds.

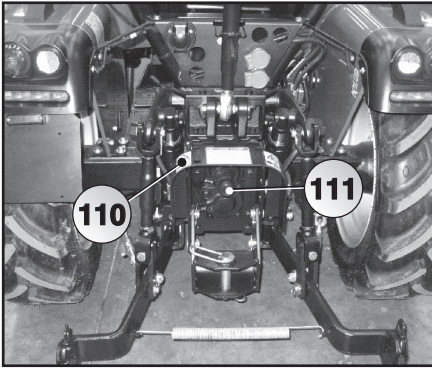

Fig. 2.17

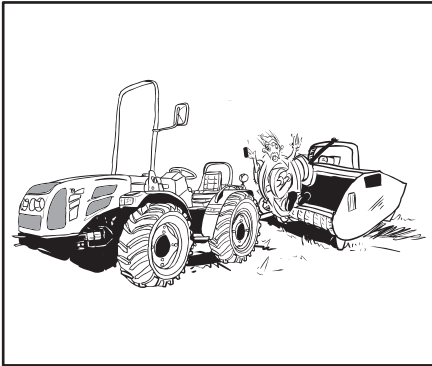

Fig. 2.18

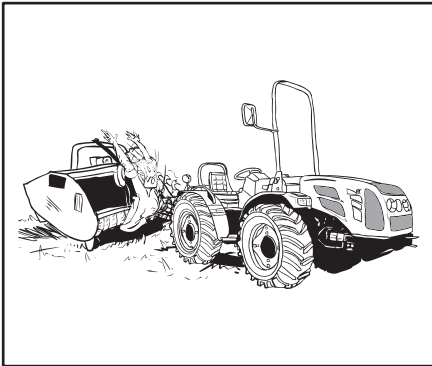

Fig. 2.19

SAFETY

Section 23 : Implements and hitches

- The implements installed on the three-point hitch or laterally have a radius of turning space greater than implements towed from the drawbar. Make sure that there is enough space for the turn.
- When using implements or equipment with the tractor, read the part of the operator instruction booklet regarding these implements and equipment carefully and observe the recommended safety regulations.
- Tow from the drawbar only.
Towing or hitching from other points can cause the tractor to overturn (Fig. 2.20).
- Improper use of the drawbar, even if positioned correctly, can cause longitudinal overturning backward.
- Improper use of the drawbar, even if positioned correctly, can cause longitudinal overturning backward.
- Use ballasts as recommended. NEVER add additional ballasts to compensate for a load that is heavier than permitted. Reduce the load.
- A safety chain will control the towed implement if it accidentally becomes separated from the drawbar while being transported. Using appropriate adaptors, attach the chain to the support of the tractor's drawbar or to other specified anchoring points. Leave the chain fairly free so that turning is possible. Ask your dealer for a chain that has a capacity equal to or above the gross weight of the towed machine.
- The implements must be hitched and unhitched when the tractor is on flat ground without obstructions.
- Do not hitch implements with characteristics that are unsuited to those of the tractor (power, weight, etc.).
- Connect to the driveline in the correct way and make sure that the safety pro-

tections are perfectly efficient.

- First connect the driveline to the PTO of the implement and then to that of the tractor. Connect the safety chains correctly, to prevent the driveline protections from turning.
- Make sure that the driveline is the right length.
- Never operate the PTO unless the driveline that connects to the implements has been installed correctly.
- Never operate the driveline when manoeuvring the tractor, driving on the roads or when the implement is not in its operating position.
- Do not unhitch the implement unless it is resting on the ground and when the tractor has been stopped in safe conditions.
- Never use the front hook to tow implements.
- Hitch and tow implements that are preferably equipped with an independent braking system. Towed implements without independent braking systems may only be hitched if the weight (empty and with a full load) is within the permitted values.
- Do not make the hydraulic or electrical connections of the implement or insert any retention devices (plugs, split pins, etc.) unless the tractor has been stopped in safe conditions.
- Always lower the implement to the ground before leaving the tractor.

Section 24 : Driving on roads

Before driving the tractor on public roads, take appropriate precautions.

- Observe the local and national rules of the road that apply to your tractor.
- Couple both brake pedals (RS model).
- Lift the implements into the transportation position and lock them into place.
- Place the implements in the tightest transportation configuration
- Disengage the power take-off and differential lock.
- Make sure that the tractor and any other implements have slow moving vehicle symbols or a rotating light, if provided for by law (Fig. 2.21).
- If the mounted implements project from the sides of the tractor, the overall width must be indicated by fitting panels with red and yellow stripes on the side ends. Make sure that the revolving beacon is installed and that it functions correctly.
- Make sure that flags or flashing lights are installed and function correctly.
- Make sure that an appropriate safety plug with a suitable safety restraint is used.
- Thoroughly clean all of the front and rear lights and make sure that they function correctly.
- Implements installed on the three-point hitch and implements that project out to the side when turning have a greater turning radius than towed implements. Always maintain a safe amount of space when turning.

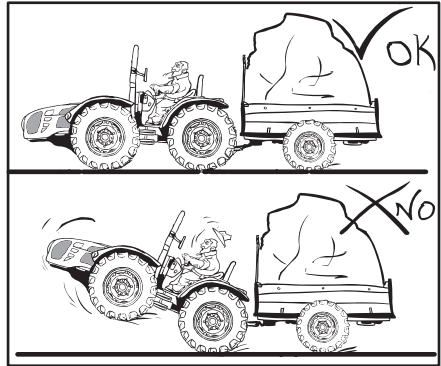

Fig. 2.20

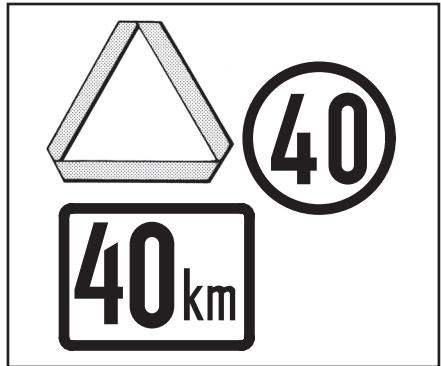

Fig. 2.21

Section 25 : Rules of the road

Take appropriate precautions when driving the tractor on public roads.

Warning:

Do NOT allow other passengers to climb onto the tractor or the towed implement.

- Make sure that you are familiar with the road that you will travel.
- Use intermittent lights or the rotating light during the day and at nighttime, unless prohibited by law, on roads.
- Take care when towing loads at transportation speed, especially if the towed implement is NOT equipped with brakes.
- Observe local and national regulations regarding the speeds allowed for your tractor.
- Pay very careful attention when driving on surfaces covered with snow and on slippery roads.
- Wait until the road is clear before pulling out.
- Be very careful at blind intersections. Slow down until visibility is safe.
- Do NOT attempt to overtake at junctions.
- Always signal your intention to slow down, stop or turn.
- Engage a slow gear before starting downhill or uphill (Fig. 2.22).
- Keep the gear engaged. Never drive downhill with the clutch disengaged or the gear in neutral (Fig. 2.23).
- Do NOT impede approaching traffic.
- Drive in the correct lane, staying near the edge of the road as much as possible.
- If the traffic increases behind you, pull over and let it pass.
- Pay attention when driving. Anticipate the maneuvers that others could make.
- When towing a heavy load, start bra-

- king early and slow down gradually.
- Be careful of overhead obstructions.

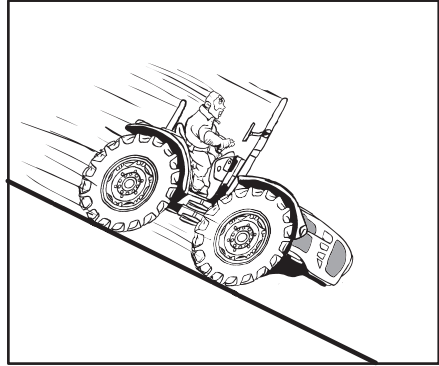

Fig. 2.22

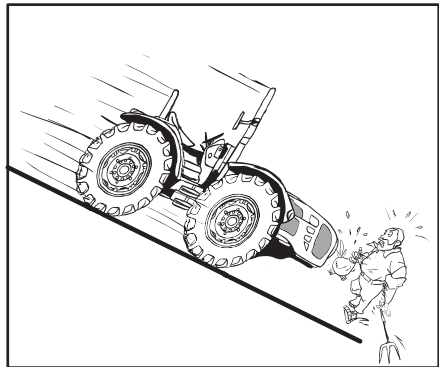

Fig. 2.23

Section 26 : Safety - After use

Whenever stopping work, bring the tractor to a halt safely (do NOT park the tractor on a descent), engage the parking brake, disengage the power take-off, place all of the gear levers in neutral, lower the implement to the ground completely, turn off the engine and remove the ignition key **BEFORE** leaving the operator position.

Section 27 : Personal protection equipment against noise

Personal protection equipment lessens the sound intensity transmitted to the ears through the air.

It should be used when harmful exposure cannot be avoided in other ways.

Various types with different attenuation capacities exist: helmets, earmuffs, earplugs (Fig. 2.24).

Helmets and earmuffs offer the greatest muffling but are bulky and annoying and therefore are useful for exposure to high noise levels for short periods of time (max. 2 hours).

Earplugs are generally better tolerated and are especially useful in the case of long exposure to less intense noise.

If the daily exposure level to noise is equal to or higher than 85 dBA, adequate personal protection equipment for protecting hearing should be used.

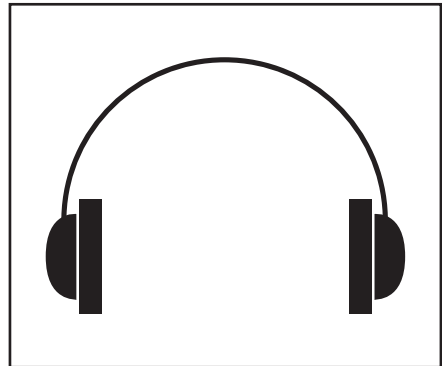

Fig. 2.24

Section 28 : Position of safety decals

The following safety decals must never be removed from their original position on the tractor. If, for reasons of maintenance or deterioration, they need removing or become illegible replace immediately, contact your nearest dealership for replacements.

28.1 58074880 (Fig.2.26)

General risk

WARNING: read the user and maintenance booklet of the tractor and the engine for information on safety and use of the tractor.

Located on the dashboard just under the steering wheel.

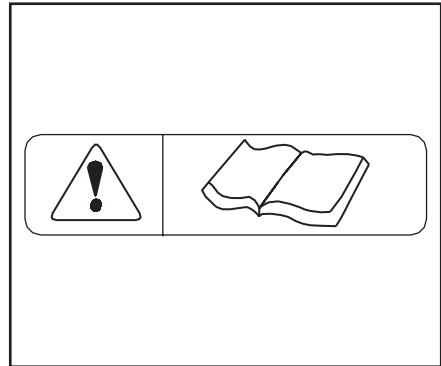

Fig. 2.25

28.2 580A1016 (Fig.2.25.1)

Danger of burns

Fare **Attenzione:** superfici surriscaldate, pericolo ustioni.

WARNING: Very hot surfaces. Danger of burns.

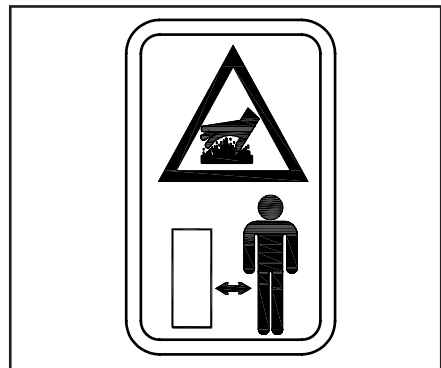

Fig. 2.25.1

28.3 580A1607 (Fig.2.25.2)**Danger of entanglement**

Take **care**: keep well away from spinning shafts. Take care NOT to remain caught up by the PTO driveline. Keep all the guards mounted on the transmission shafts, on the tractor and on the implements.

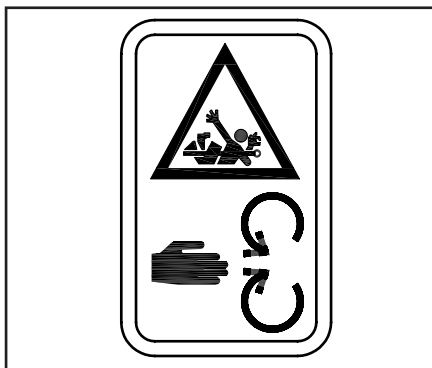

Fig. 2.25.2

28.4 580A1606 (Fig.2.25.3)**Danger of being crushed**

Take **care**: risk of parts of the body being crushed. Keep will away of the area when the components are on the move.



Fig. 2.25.3

28.5 580A1605 (Fig.2.25.4)**Danger of overturning**

Take **care**: never use the tractor when the protective structure is lowered.

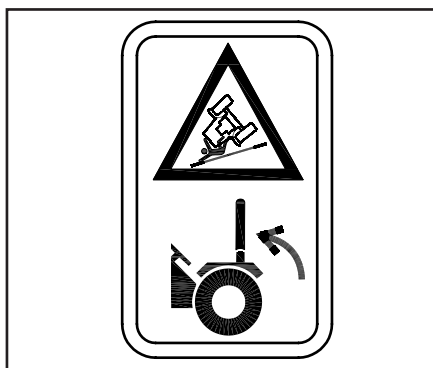

Fig. 2.25.4

28.6 58076077 (Fig.2.26)

Use of the PTO while the vehicle is not running

WARNING: Risk of dragging. Stay away from the rotating shafts. Be careful not to get caught by the PTO propeller shaft. Leave all of the guards installed on the drive shafts, tractor and implements.

On the rear right fender on the inside just above the lift control levers.

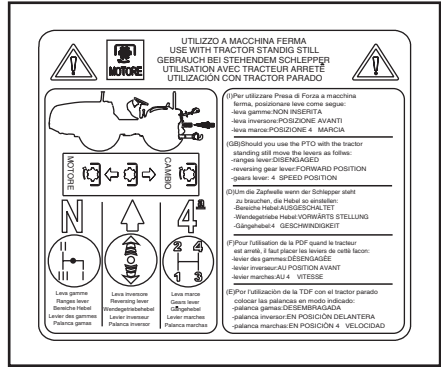

Fig. 2.26

28.7 580A1608 (Fig.2.27)

Center articulated joint warning

WARNING: Risk of crushing. Stay away from this area when turning. Do not stand near the center joints.

On the front right fender near the center joint.

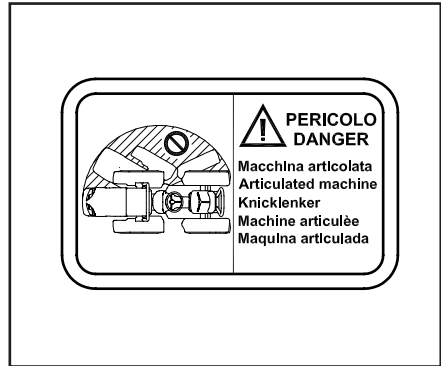

Fig. 2.27

28.8 580A1037 (Fig.2.27.1)

Danger: Moving power takeoff

Pay Attention: switch off the engine. Stand away from the power takeoff shaft when it is moving.



Fig. 2.27.1

28.9 580A1039 (Fig.2.27.2)**Danger: Moving mechanical parts**Pay **Attention**: switch off the engine, moving mechanical parts.

Fig. 2.27.2

28.10 580A1038 (Fig.2.27.3)**Danger: pressurised cooling circuit.**Pay **Attention**: switch off the engine. Before removing the radiator cap, wait for the circuit to cool.

Fig. 2.27.3

28.11 AR model tractor

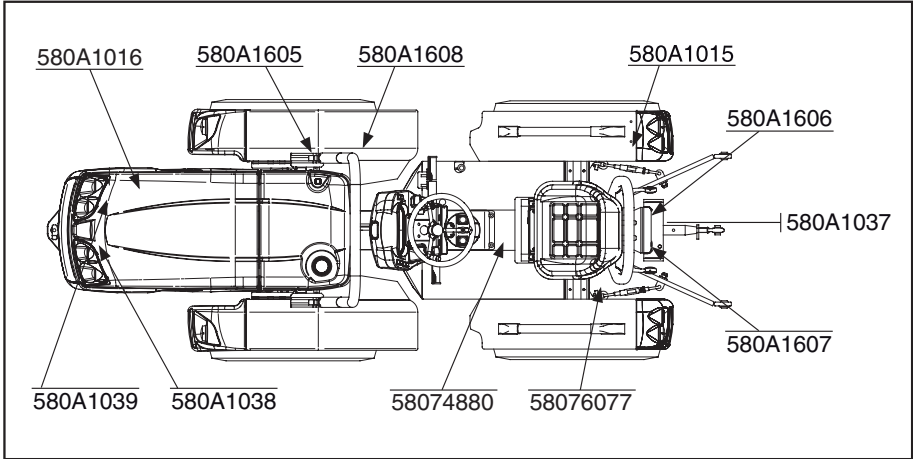

Fig. 2.28

28.12 RS model tractor

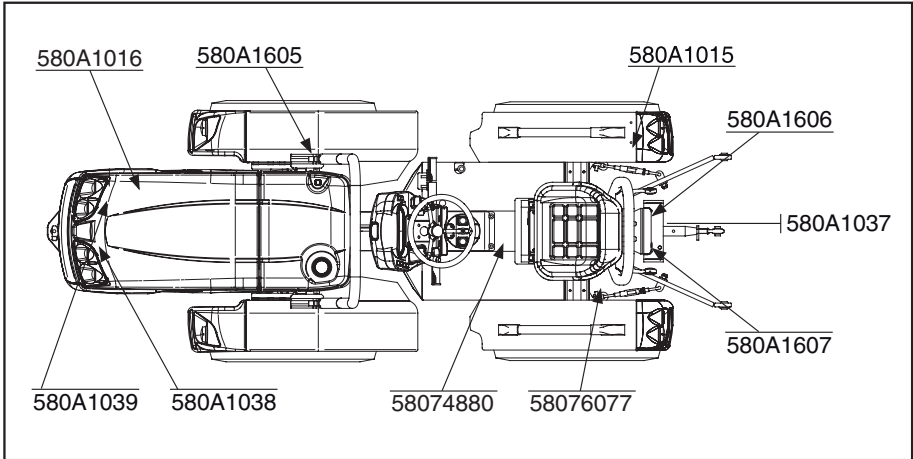

Fig. 2.29

Section 29: Using the loaders

Fastening points have not been designed on the tractor for enabling a front loader assembly.

The tractor does not have any programmable functions with hydraulic sequential control.

Section 30: Forestal use

The tractor is not fitted with fastening points for the installation of protective structures (FOPS) and has no optional equipment.

Section 31: Using the sprayers

Always remember that exposure to phytosanitary products can cause acute, chronic intoxication and allergic reactions irrespective of the hazard class to which the substance belongs (highly toxic, toxic, etc). Activities that expose farmers to phytosanitary products vary from the preparation of mixtures, distribution, decontamination of vehicles and equipment used, to agronomical activities in treated plots of land. All operatives should be aware of the risks to which they are exposed.

In the case of tractors with open roll bar, it is necessary to use suitable "PERSONAL PROTECTIVE EQUIPMENT" (rubber non-slip boots and gloves, double filter mask; overall, protective eyewear and so on).

- After treatment work, always wash clothing with soap and water.
- Do not wear casual clothing during treatment work.
- In the event of poisoning, immediately seek medical attention or a medic presenting the toxicological sheet.
- **Carefully clean the machine after carrying out treatments.**

Note:
Treatment residues are classed as "hazardous special waste", and therefore should be sent to specialised facilities to be processed in suitable hazardous waste treatment systems.

Chapter 3 : Technical data and characteristics

Contents

Section 1 : Weights and dimensions	50
1.1 AR Tractor	50
1.2 RS Tractor	51
Section 2 : Engine	52
2.1 Noise level emissions in the environment (Directive 2009/63/EC).....	52
2.2 Noise level in the driver's ears (Directive 2009/63/EC)	52
2.3 Vibration level of the driver's seat (Directive 78/764/EEC) ..	53
Section 3 : Clutch	53
Section 4 : Gearbox	53
Section 5 : Rear drive.....	53
Section 6 : Differential block.....	53
Section 7 : Four-wheel drive	54
Section 8 : Power take-off	54
Section 9 : Service brakes	54
Section 10 : Parking brake	54
Section 11 : Front axle	55
Section 12 : Hydraulic circuit.....	55
Section 13 : Rear hydraulic lift	55
Section 14 : Hydraulic direction control valves.....	56
Section 15 : Steering.....	57
Section 16 : Implement hitch.....	58
Section 17 : Towing hitches.....	69
Section 18 : Impianto elettrico.....	60
Section 19 : Rollbar	61
Section 20 : Body	61
Section 21 : Operator position and seat.....	61
Section 22 : Front and rear wheels	62
Section 23 : Supplies table.....	63

Section 1 : Weights and dimensions

1.1 AR Tractor

Curb weight:	1510 Kg.
--------------	----------

Dimensions

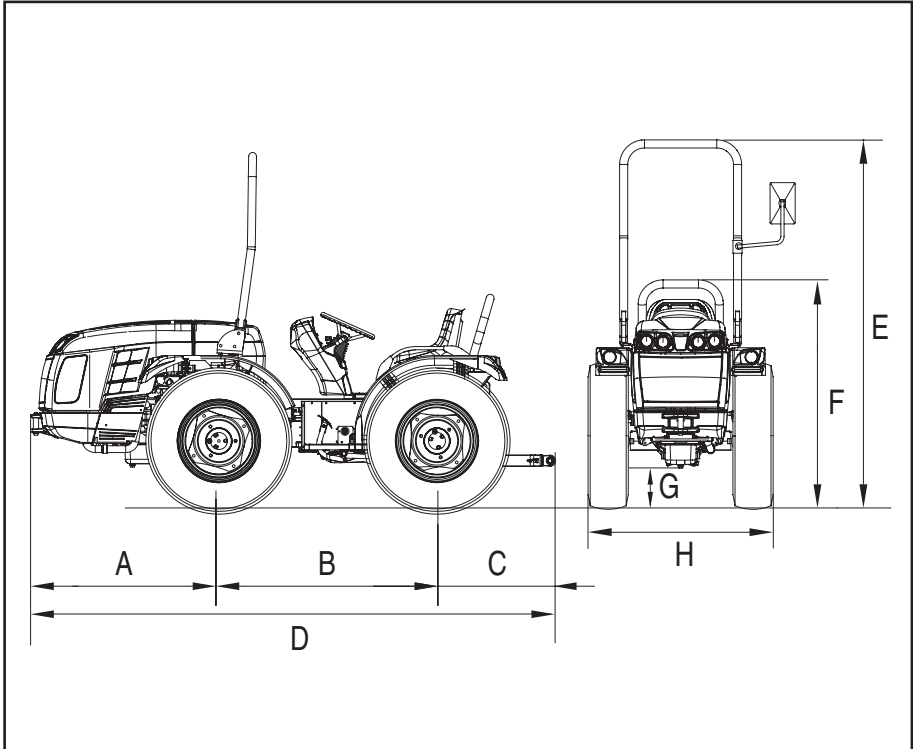

Fig. 3.1

	A	B	C	D	E max	F min max	G min max	H min max
mm	1160	1340	730	3230	2220	1179 1238	220 270	1002 1438

1.2 RS Tractor

Curb weight:	1520 Kg.
--------------	----------

Dimensions

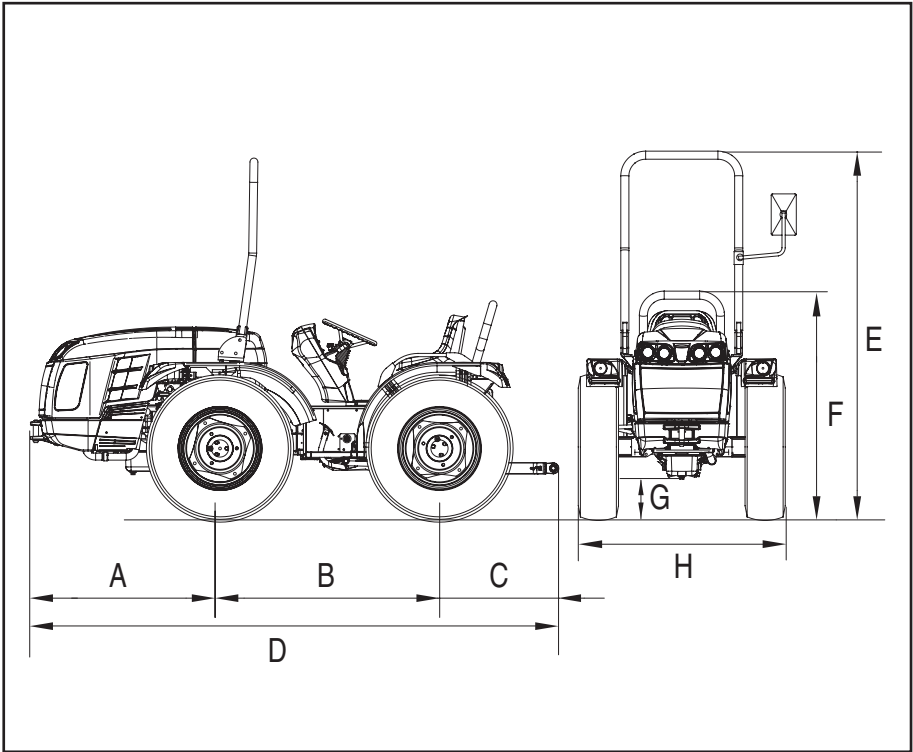

TECHNICAL DATA

Fig. 3.2

	A	B	C	D	E max	F min max	G min max	H min max
mm	1160	1340	730	3230	2220	1179 1238	220 270	1207 1667

Section 2 : Engine

Manufacturer	KOHLER
Type	KDi 2504M
N° of cylinders	4
Displacement (cc)	2482
Aspiration	natural
Emissions level	Stage III A
Power (KW/CV)	36,5/50
Rated speed (rpm)	2600
Maximum torque (Nm/rpm)	170/1500
Cooling	liquid
Specific fuel consumption (g/KWh)	220
Tank capacity (l)	45

2.1 Noise level emissions in the environment (Directive 2009/63/EC)

Machine noise level stationary dB (A)	83
Machine noise level moving dB (A)	86,3

2.2 Noise level in the driver's ears (Directive 2009/63/EC)

Machine noise level dB (A)	85,6
----------------------------	------

2.3 Vibration level of the driver's seat (Directive 78/764/EEC)

	MASS 60 Kg.	MASS 100 Kg.
GT50 - M91	1,13 m/s ²	0,75 m/s ²
GT60 - M91	1,13 m/s ²	0,75 m/s ²
XH2 P1	1,17 m/s ²	0,93 m/s ²
XH2 P2	1,17 m/s ²	0,93 m/s ²
450 - S22	0,99 m/s ²	1,07 m/s ²
COMPACT - S22	0,99 m/s ²	1,07 m/s ²

Section 3 : Clutch

The transmission clutch is a mechanically-actuated, multi-plate, oil-immersed clutch. The PTO clutch is a electrohydraulically-actuated, multi-plate, oil-immersed clutch and brake in the disengaged position.

Section 4 : Gearbox

The constant mesh gearbox with helical gearing has 4 speed gears, 3 working ranges and a reverser. A total of 24 speeds are available: 12 forward and 12 reverse.

Gears and reverser have synchronized engagement.

Section 5 : Rear drive

Hypoid differential bevel gear with electrohydraulic locking.

Final epicyclic reduction gears on the wheels.

Section 6 : Differential block

Front and rear differential with simultaneous electrohydraulic locking.

Section 7 : Four-wheel drive

There is permanent four-wheel drive.

Section 8 : Power take-off Independent Power Take-Off for implements or machine tools.

The independent PTO is engaged by means of an electrohydraulically-actuated multi-plate oil-immersed clutch. The PTO output shaft rotates to the right in forward gear.

Synchronized Power Take-Off for trailers.

Below, the rpm values of the synchronized PTO shaft are given for each revolution of the rear wheel:

- PTO 540: 6,634 rpm

Section 9 : Service brakes

The service brakes on the rear wheels are mechanically-actuated, multi-plate and oil-immersed.

They are activated by one pedal in the AR model and two pedals in the RS model for forward operation and one pedal only for reverse operation.

For simultaneous braking on roads, the pedals have to be coupled using the relevant lockbolt.

Section 10 : Parking brake

The parking brake acts on the service brakes and is mechanically controlled using a manual lever.

Section 11 : Front axle

The front axle oscillates at the center (approx. $\pm 15^\circ$) and is always in drive.

Engagement of the front and rear differential lock is simultaneous with an electrohydraulic command from the switch on the dashboard.

Section 12 : Hydraulic circuit

The circuit is equipped with two independent hydraulic pumps controlled by the power distribution gears.

One pump controls the hydraulic steering gear and services (differential locking device, p.t.o. clutch) the other pump controls the hydraulic lift and additional distributors.

Hydraulic steering gear capacity:

15,4 l/min.

Lift pump capacity:

25,6 l/min.

Section 13 : Rear hydraulic lift

The rear hydraulic lift is available in two mechanically-controlled configurations:

- position control, draft control, and combined position and draft control.
- position control, draft control, and combined position and draft control.

The lifting capacity is 1200 kg at the ball joints of the lift arms.

Section 14 : Hydraulic direction control valves

The additional hydraulic directional control valves are mechanically controlled with up to 6 hydraulic ports.

The standard configuration:

- one-piece double-acting directional control valve with “raise-lower” function.

As an option, the following is available:

- 1 single acting directional control valve and 1 double-acting floating directional control valve;
- 2 double-acting directional control valves.

Notes:
In order to guarantee the correct maneuverability of the hydraulic equipment, it is advisable to use lock valves on the hydraulic drive connected to the double-acting hydraulic ports.

Section 15 : Steering

The tractor has hydrostatic steering incorporated in the dashboard. A double-acting hydraulic jack is present on the central joint on the AR model and on the front axle on the RS model

Steering angle:

- AR model - approx. 38°
- RS model - approx. 46°

The steering wheel height is adjustable on the AR model while steering regulation is oscillating on the RS model.

The turning radius depends on the type of tires installed as shown below:

Type of tire	Turning radius (mm)	
	AR	RS
8.25-16	2450	2800
250/80-18	2500	2830
280/70-18	2530	2930
320/65-18	2650	2950
260/70-20	2600	3350
31x15.50-15	2700	3250
31x13.50-15	2700	3200

Section 16 : Implement hitch

Cat. three-point hitch with side stabilizers for controlling lateral sway of implements.

Third point tie rod and vertical tie rods with manual regulation.

On request, the third point tie rod is available with quick coupling.

The lifting capacity is 1200 kg at the ball joints of the lift arms.

Section 17 : Towing hitches

The tractor is equipped with a front maneuver hitch.

Two types of rear hitches are available, depending on the norms of individual countries:

- Category C hitch, approved for Italy, 6 positions for height adjustment;
- Hitch for European approval.

The maximum weight that the tractor can tow varies depending on the laws in force in individual countries.

Maximum towable mass (unbraked):

RS version	1550
AR version	1550

Maximum towable mass (with independent braking system):

RS version	4650
AR version	3100

Maximum towable mass (with inertia braking):

RS version	4650
AR version	3100

Section 18 : Electric system

Voltage
12 V

Battery

type	“Maintenance Free”
Voltage	12 V
Capacity	100 Ah

Alternator

type	80 A
Voltage	14 V
Potenza	1120 W with built-in automatic voltage regulator

Starter motor

Voltage	12 V
Sustained power	2 kW

Rear auxiliary electrical outlet

7 pin

Headlights

four front optical groups with halogen lamps: two dipped headlights, two full beam headlights and two position lights;

for orange indicator lights;

two tail lights including position light red brake light;

two red reflectors;

number plate light and rear working light;

Fuses

Safety fuses on the bottom right-hand side of the dashboard.

Section 19 : Rollbar

The front safety frame is securely fixed to the tractor's transmission and can be lowered for particular maneuvers.

Section 20 : Body

The engine hood opens at the front.

Partially wrap-around fenders.

Diesel tank and battery under the hood.

Section 21 : Operator position and seat

In the reversible model, the operator position revolves for using the tractor in reverse mode. The brake pedals and clutch are fixed to the transmission.

Adjustable steering wheel.

Sprung seat equipped with safety belts.

Springs can be adjusted to the operator's weight.

Section 22 : Front and rear wheels

To adjust the wheel track, see the tables in chapter 5, User Regulations.

Tires	Wheel radius under load	
	mm	inch
8.25-16	375	14.76
250/80-18	393	15.47
280/70-18	380	14.96
320/65-18	400	15.75
260/70-20	396	15.59
31x15.50-15	350	13.78
31x13.50-15	356	14,02

Section 23 : Supplies table

The engine cooling circuit consists of a mixture of a special coolant and distilled water in variable proportions.

These are the reference values:

antifreeze (%)	freezing point (°C)	boiling point (°C)
30	-15	104
35	-20	105
40	-25	106
45	-30	107
50	-35	109
60	-36	113

For the engine lubrication circuit quantities, see the instruction manual for the engine supplied with the tractor.

Always store it in a safe place.

Quantity	AR	RS	type
Fuel tank	45 lt	45 lt	diesel
Front axle	6.5 lt	5 lt	BCS POWERLUBE W13T oil
Reduction gear of front wheels	-	0.75 lt	BCS POWERLUBE W13T oil
Gearbox-rear axle unit and rear reduction gears	14.5 lt	16 lt	BCS POWERLUBE W13T oil
Engine cooling circuit coolant	8.5 lt	8.5 lt	antifreeze/distilled water mixture

Chapter 4 : Instruments and controls

Contents

Section 1 : General view of controls.....	66
Section 2 : Digital instrument panel	69
Section 3 : Steering wheel adjustment.....	71
Section 4 : Standard seat adjustment	72
4.1 Vertical adjustment (operator weight)	72
4.2 Longitudinal adjustment.....	73
4.3 Height adjustment (vertical)	73
Section 5 : “Bostrom” seat adjustment	74
5.1 Operator weight adjustment.....	74
5.2 Longitudinal adjustment.....	75
5.3 Suspension adjustment.....	75
Section 6 : Rotating light	76

Section 1 : General view of controls

This paragraph provides an overview of all of the instruments and controls on the tractor.

Unless otherwise specified, they apply to the AR, and RS versions.

To use the controls listed here correctly, read chapter 5 - User Regulations carefully.

- User Regulations carefully.
- 1 - Clutch disengagement pedal
- 2 - Working range lever
- 3 - Direction lever
- 4 - Gearshift lever
- 5 - Brake pedals (RS model)
- 6 - Brake pedals (AR model)
- 7 - Accelerator pedal
- 8 - Steering wheel
- 9 - Steering wheel height lever
- 10 - Lights switch and horn
- 11 - Ignition switch
- 12 - PTO engagement switch
- 13 - Differential lock engagement switch
- 14 - Auxiliary electrical outlet (12 V)
- 15 - Emergency switch
- 16 - Hand accelerator lever
- 17 - Parking brake lever

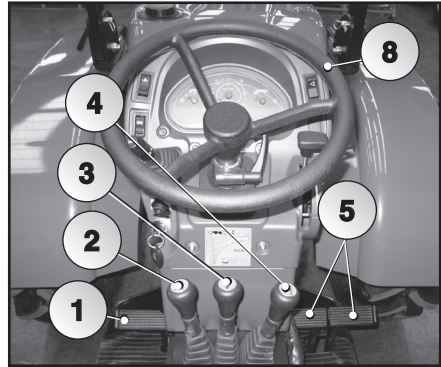

Fig. 4.1

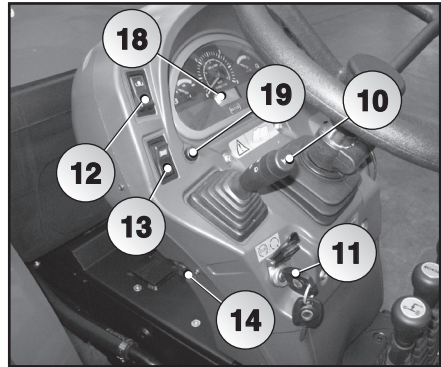

Fig. 4.2

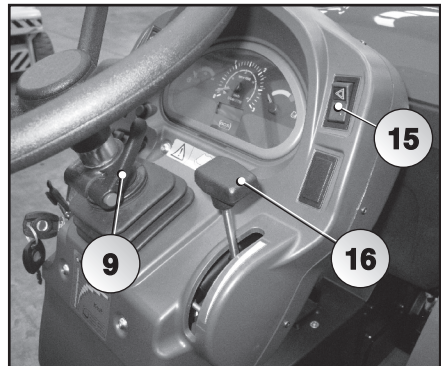

Fig. 4.3

- 18 - Digital instrument panel
- 19 - Digital panel functions button
- 20 - Up/down lift lever
- 21 - Lift arms down speed knob
- 22 - Single acting spool valve control lever
- 23 - Double acting spool valve control lever
- 24 - Position control lever (yellow) for pos./draft lift control
- 25 - Draft control lever (red) for pos./draft lift control
- 26 - Lift arms down speed lever

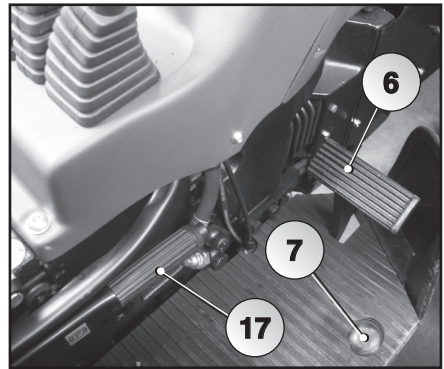

Fig. 4.4

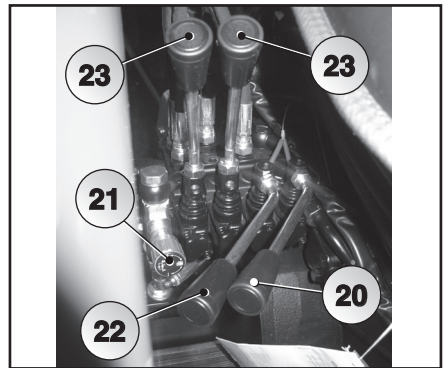

Fig. 4.5

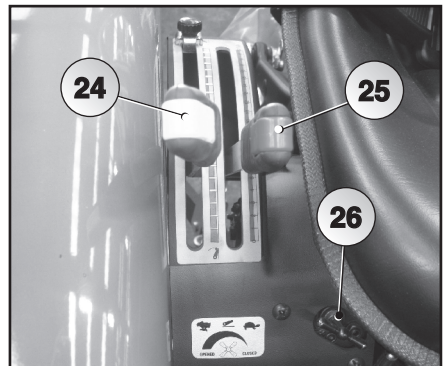

Fig. 4.6

- 27 - Independent or synchronized PTO lever
- 28 - Electrical outlet for trailer
- 29 - Flow switching lever
- 30 - Lift lever (hydraulic suspension model)
- 31 - Accumulator charge/discharge lever (hydraulic suspension model)
- 32 - Double-acting control valve lever with mechanical connection
- 33 - Pressure gauge
- 34 - Control valve

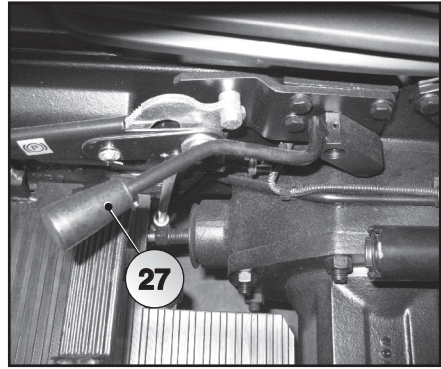

Fig. 4.7

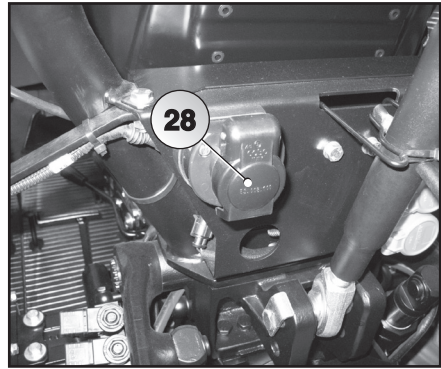

Fig. 4.8

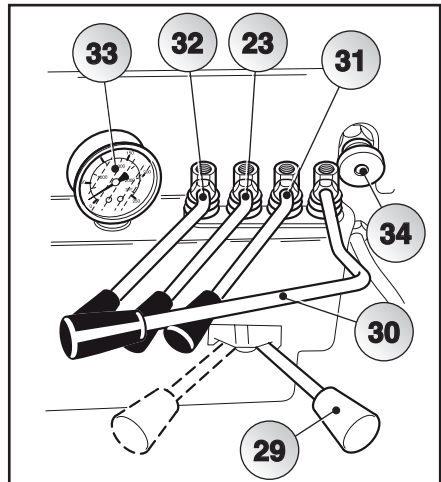

Fig. 4.9

Section 2 : Digital instrument panel

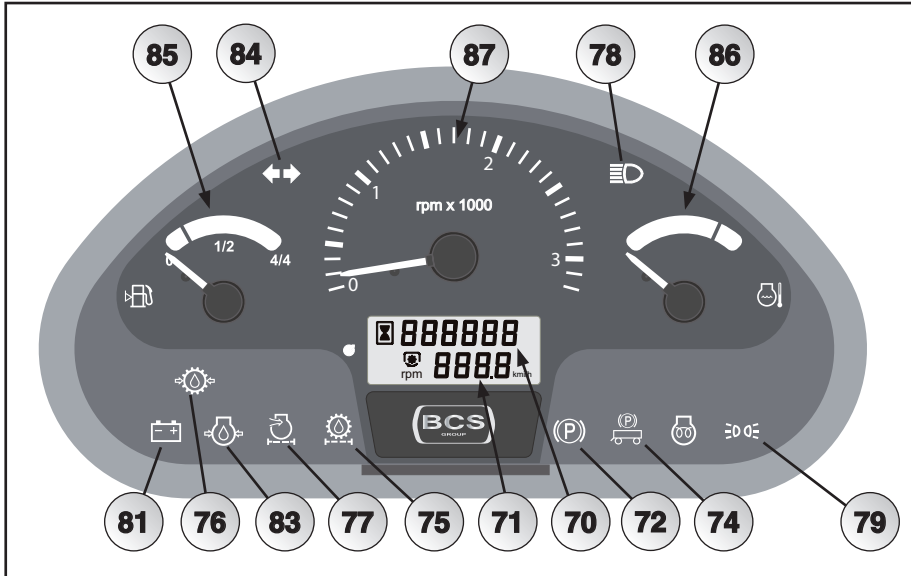

Fig. 4.10

70	Operation hours indicator	
71	PTO rpm / kph indicator	
72	Parking brake engaged light	red
73	Fast range	
74	Trailer parking light	red
75	Transmission oil filter light	red
76	Transmission oil pressure light	red
77	Engine air filter light	red
78	Full beam headlights light	blue
79	Position lights light	green
80	Slow range	
81	Battery light	red
83	Engine oil pressure light	red
84	Turn signal light	green
85	Fuel level indicator	
86	Engine water temperature indicator	
87	Engine rpm indicator	

Digital display

By turning the ignition key (12) to the simple contact position, as when starting the engine;

The display shows two pieces of information:

- the upper number (LCD1) indicates the working hours;
- the lower number (LCD2) indicates the tractor speed (kph).

Using the button (21) the function of the information provided in the LCD1 position can be varied in order to display the PTO rpm.

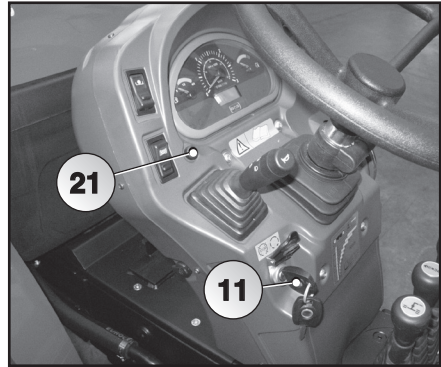

Fig. 4.11

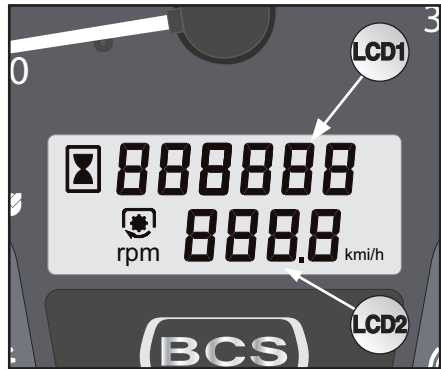

Fig. 4.12

Section 3 : Steering wheel adjustment

The wheel activates the power steering:

- the center joint for AR tractor steering;
- the wheels for RS tractor steering.

 Warning:

Adjust the steering wheel height when the tractor is not moving.

The steering wheel height may be adjusted by rotating the provided lever (9). The movement of the lever (9) releases the steering wheel position, allowing it to be adjusted to the height of the operator.

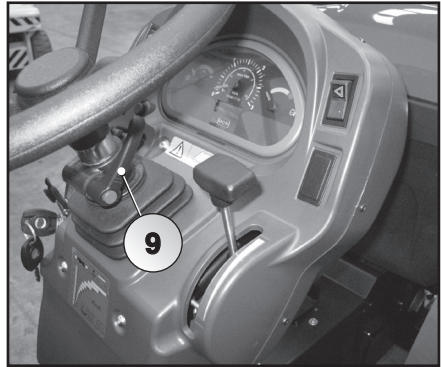

Fig. 4.13

Section 4 : Standard seat adjustment

The tractor seat is equipped with devices for longitudinal, height and vertical adjustment according to the operator's weight.

 **Warning :**

Adjust the seat position when the tractor is not moving.

4.1 Vertical adjustment (operator weight)

The seat suspension may be adjusted according to the operator's weight using the lever (42) under the rubber guard of the suspension itself.

To adjust:

- Pull the lever (42) outward;
- Turn the lever (42) clockwise to increase the weight sustained by the suspension; turn the lever (42) counter-clockwise to reduce the weight sustained by the suspension.

Note:

The longitudinal setting and height of the seat should be adjusted while the operator is sitting on the seat itself.

4.2 Longitudinal adjustment

The required position is achieved using the lever (40) and moving the seat longitudinally (forward or backward). After it has been adjusted, release the lever (40) to lock the seat in place.

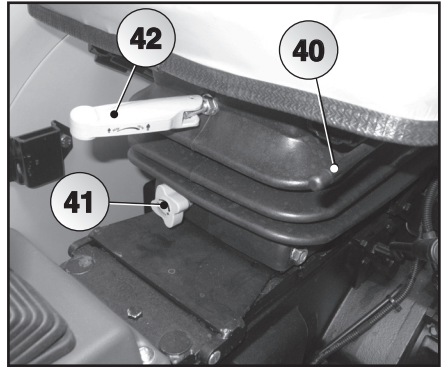

Fig. 4.14

4.3 Height adjustment (vertical)

Use the knob (41) to adjust the seat height. When turned clockwise, the seat is lowered; when turned counter-clockwise, the seat is raised.

Section 5 : “Bostrom” seat adjustment

The seat suspension may be adjusted longitudinally and is also equipped with a device which allows the vertical travel of the seat to be adjusted according to the weight of the operator.



Warning :

Adjust the seat position when the tractor is not moving.

5.1 Operator weight adjustment

The lever (45) allows the adjustment device to be prepared according to the weight of the operator, while the index (46) displays the value compared to the data plate.

To adjust:

- pull the lever (45) outwards;
- turn the lever knob so that the + symbol appears in the window if the operator weighs more than the currently selected value or the - symbol appears if the operator weighs less;
- then activate the lever so that the index (46) is in the desired position; once adjustment has been completed, turn the lever (45) back inwards;
- once the seat has been adjusted according to the weight of the operator, subsequent adjustments must be carried out with the person sitting on the seat itself, observing the following procedure.

5.2 Longitudinal adjustment

Note:

It is advisable to perform longitudinal and height adjustments to the seat while the operator is actually sitting on the seat.

Activate the lever (43) and move the seat longitudinally into the required position; once adjustment has been completed, release the lever and make sure that the seat is locked in place.

5.3 Suspension adjustment

Move the knob (44), sliding it into the slit until it is positioned on a level with the required vertical adjustment value as shown on the data plate.

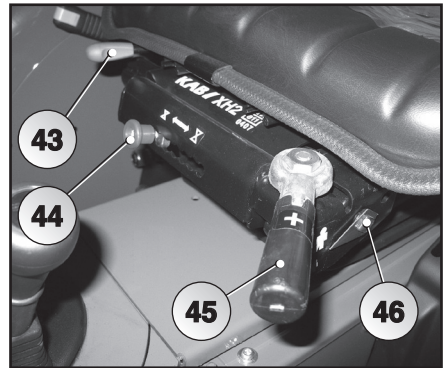

Fig. 4.15

Section 6 : Rotating light

The rotating light must be installed, if necessary, on the rollbar.

It is turned on by inserting the connector of the “rotating light” kit into the auxiliary electric outlet (16) (12V) on the left-hand side of the dashboard.

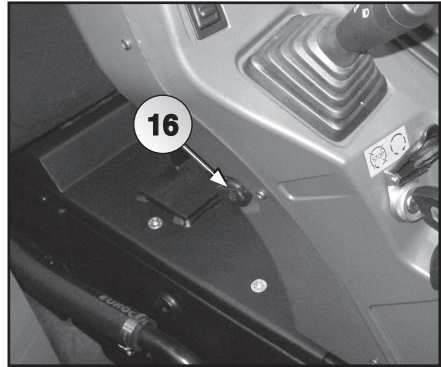

Fig. 4.16

Chapter 5 : User regulations

Contents

Section 1 : Operator position direction (reversible)	78
Section 2 : Starting the engine	80
Section 3 : Starting the engine with a low outdoor temperature ..	82
Section 4 : Running-in	82
Section 5 : Turning off the engine	83
Section 6 : Starting the tractor	84
Section 7 : Pedal accelerator	85
Section 8 : Hand accelerator	86
Section 9 : Stopping the tractor	87
Section 10 : Battery disconnecter	88
Section 11 : Clutch pedal	89
Section 12 : Transmission levers	90
12.1 Range lever	90
12.2 Reverser lever	90
12.3 Gearshift lever	91
Section 13 : Service and parking brakes	93
Section 14 : Controls on the dashboard	95
Section 15 : Power Take-Off	97
Section 16 : Differential lock	103
Section 17 : Hitch	104
17.1 Maximum vertical load on Rear coupling - "RS" version	110
17.2 Maximum vertical load on Rear coupling - "AR" version	112
Section 18 : Three-point hitch	114
18.1 Standard rear lift	123
18.2 Rear lift with hydraulic suspension	124
18.3 Rear lift with position and draft control	125
18.4 Auxiliary hydraulic directional control valves	127
Section 19 : Removing the tyres	129
19.1 Adjusting the wheel track	130
Section 20 : Transporting the tractor	133
Section 21 : Front ballasts	134

Section 1 : Operator position direction (reversible)

⚠ Warning :

The rollbar must always be installed and vertical when using the tractor. The rollbar itself may be folded forward only to temporarily reduce the overall height of the tractor.

The tractor operator position may be directed in the normal direction of operation (A) or it may be reversed 180° (B).

Note:

By rotating the operator position 180°, the power steering flow reverser is automatically positioned so that the vehicle steering always corresponds to the direction of the steering wheel.

⚠ Warning :

The operator position must be in the normal operation direction when driving the tractor on roads.

To reverse the operator position, the following instructions must be observed:

⚠ Warning :

The engine must be off and the parking brake must be engaged.

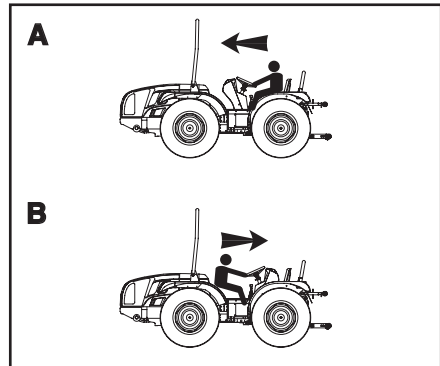

Fig. 5.1

- 1 - adjust the steering wheel to the high position;
- 2 - position the three gearbox levers (2) (3) (4) (Fig. 5.2) in neutral;
- 3 - pull the unlocking lever (121), raise the seat and keep it raised;
- 4 - Rotate the seat-dash-board unit 180° clockwise to switch from the normal driving position (on-road) to the reverse driving position; rotate anti-clockwise to switch from reverse driving position to normal driving position;
- 5 - Lower the seat again so that the lever (121) is reinserted into the locked position;

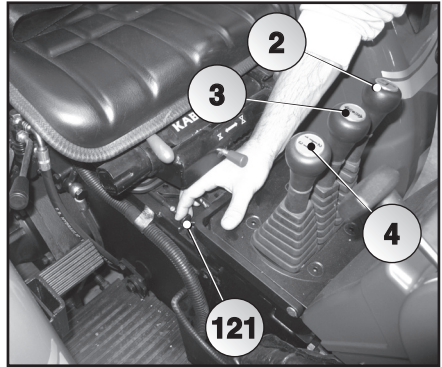

Fig. 5.2



Fig. 5.3

Section 2 : Starting the engine

 Warning:

Never run the engine in a closed environment: the exhaust gases are toxic.

 Warning:

The parking brake must always be engaged when the tractor is at a standstill and the engine is off.

 Warning:

Only start the engine when you are sitting in the driving seat.

Note:

A safety device prevents the engine from being started if the clutch pedal is not pressed down completely.

Note:

A safety device prevents the motor starting even if the engine cowl is opened.

Note:

When the ignition key is turned to 1, the digital instrument panel carries out a brief operational test, turning on all of the display lights, after which the engine operation hours appear.

- 1 - make sure that the parking brake knob (17) is in the 'brake on' position;
- 2 - make sure that all of the control levers are in neutral;
- 3 - make sure that all of the control switches are disconnected;
- 4 - press the clutch pedal down fully and keep it pressed;
- 5 - press the accelerator pedal approximately half way down;

- 6 - Insert the ignition key into the switch and turn it clockwise to position 1. Make sure that the following lights on the instrument panel come on:
 - engine oil pressure (83)
 - transmission oil pressure (76)
 - battery charging (81)
 - parking brake engaged (72)
 Turn the key clockwise, keeping it in position 2. When the engine starts, release the key which will automatically return to position 1;. Operate the starter motor for 15 consecutive seconds max. If the engine does not start, to prevent damaging the starter, wait one minute before repeating the starting operation.
- 7 - After the engine has been started, make sure that all of the red lights have gone off (except for the parking brake);
- 8 - If one of the red lights has not gone off, the engine must be turned off. Identify and eliminate the cause of the problem and repair it.

⚠ Warning:

NEVER ATTEMPT TO START THE ENGINE FOR MORE THAN 15 CONSECUTIVE SECONDS.

⚠ Warning:

To prevent accidents, never allow anyone to sit on the fenders or anywhere else on the tractor or the implement.

⚠ Warning:

When the engine is running, stay a safe distance away from the fan.

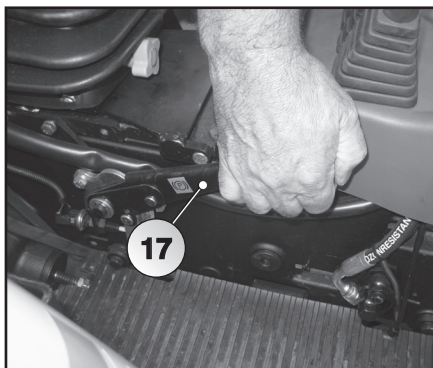

Fig. 5.4

Section 3 : Starting the engine with a low outdoor temperature

Note:

When the temperature is below or near 0°C, check and, if necessary, replenish the cooling circuit with the recommended antifreeze.

 Warning:

Do not inject fluids (ethers) to facilitate starting at low temperatures. The tractor is equipped with a cold-start system.

Section 4 : Running-in

During the running-in period, the following precautions must be observed:

- 1 - Experience has shown that the first 50 hours of tractor operation are fundamentally important for engine performance and lifetime. The tractor must be used right from the beginning in working conditions that subject the engine to a load that is as similar as possible to normal operating conditions.
- 2 - Use low gears when pulling heavy loads.
- 3 - During running-in, frequently verify the tightness of all of the screws, bolts, nuts, etc.
- 4 - For a long lifetime of the clutch, the plates must settle correctly.

Note:

Carefully engage and disengage the clutch often during the first 15 hours of tractor operation.

Section 5 : Turning off the engine

- 1 - If used, place the hand accelerator lever (16) in the minimum position;
- 2 - Turn the ignition key counter-clockwise to position 0;
- 3 - Engage the parking brake by turning the lever (17) counter-clockwise and pull it up. Make sure that the red light on the instrument panel that indicates the parking brake is engaged is on.

Note:

Do not turn off the engine when operating at full load or high rotation speed. Before turning it off, let it run at idle and with no load for about 1 minute.

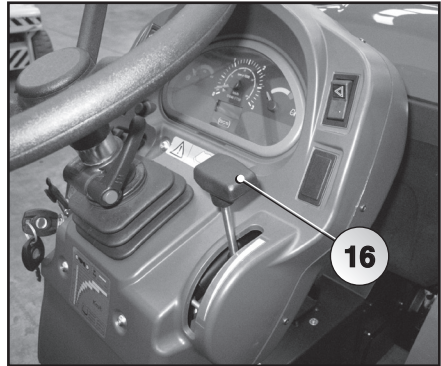

Fig. 5.5

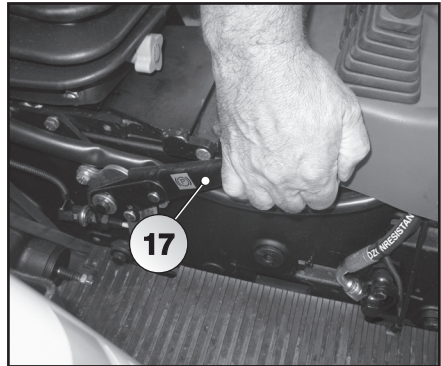

Fig. 5.6

Section 6 : Starting the tractor

⚠ Warning:

Before setting the tractor in motion, become familiar with the controls, the braking system, the transmission, the PTO, the differential lock controls and the engine stop control.

Note:

Do not exceed 75% of the maximum engine power during the first 50 hours of operation.

- 1 - With the engine running, press the clutch pedal (1) down completely;
- 2 - Select the desired gear using the lever (4);
- 3 - Select the desired range using the lever (2);
- 4 - Select the desired direction using the reverser lever (3);
- 5 - Release the parking brake, press the brake pedal (6) (AR model) or the brake pedals (5) (RS model) (Fig.4.1).
- 6 - Gradually release the clutch pedal (1) and gradually accelerate the engine with the relative pedal (7).

⚠ Warning:

Watch out for people in the vicinity, especially when in reverse

Note:

Do not drive with the clutch pedal pressed and, to prevent damage, do not neglect clutch maintenance.

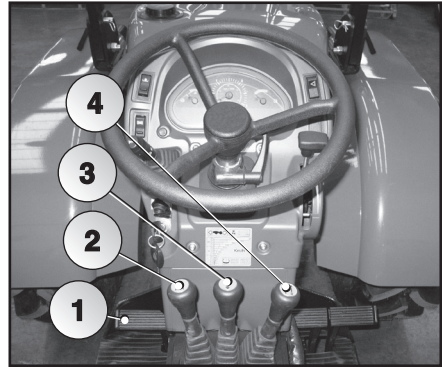

Fig. 5.7

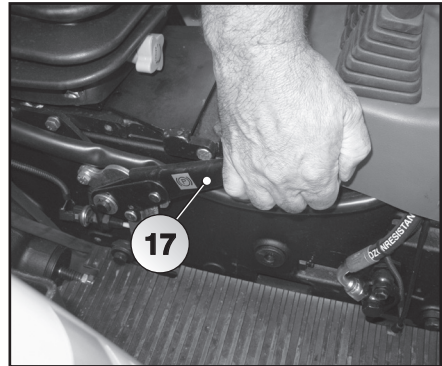

Fig. 5.8

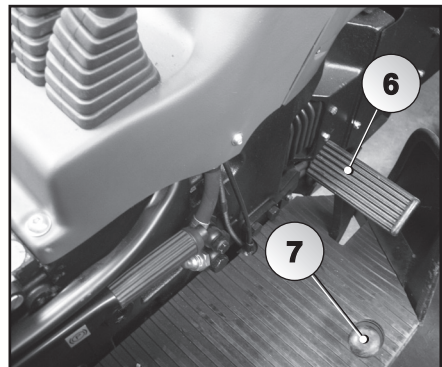

Fig. 5.9

Section 7 : Pedal accelerator

Using the pedal accelerator (7) neutralizes the position of the hand accelerator when the engine rpm increases. When the pedal is released, the engine returns to the rpm set by the hand accelerator.

The hand accelerator must be in the minimum speed position when using the pedal accelerator..

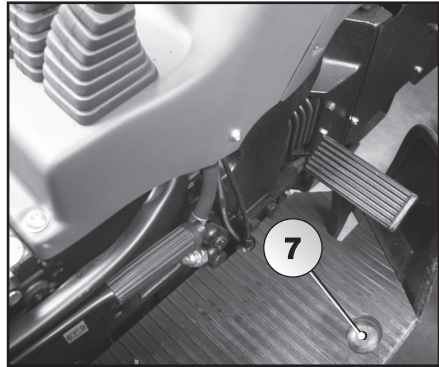

Fig. 5.10

Section 8 : Hand accelerator

The lever (16) permits manual control of the engine rpm, keeping it constant.

The lever “minimum” position corresponds to the top position; pulling it downward proportionally increases the engine rpm.

Warning:

The hand accelerator lever can only be used when a constant engine rpm is desired.

The lever must not be used when driving the tractor on roads.

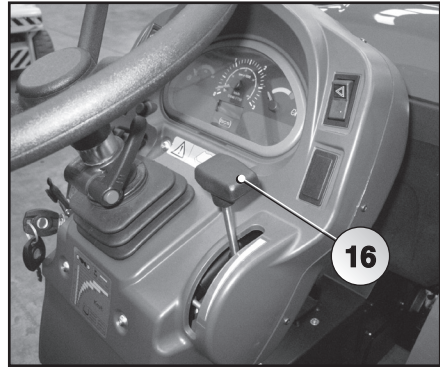

Fig. 5.11

Section 9 : Stopping the tractor

To temporarily stop the tractor:

- 1 - Ridurre la velocità del motore;
- 2 - Disengage the engine-gearbox clutch, keeping the clutch pedal (1) down completely;
- 3 - With the tractor stopped, place the gearshift lever (4) in neutral and gradually release the clutch pedal (1);

To definitively stop the tractor, follow the operations described here and the operations described in section 5 "Turning off the engine", and engage the parking brake.

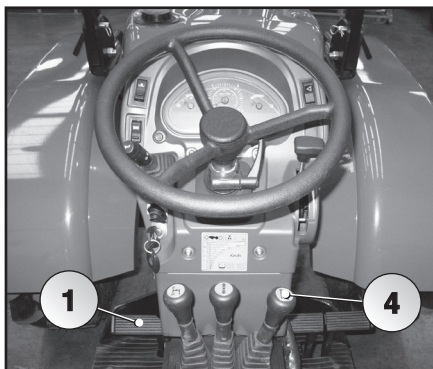

Fig. 5.12

Section 10 : Battery disconnecter

The battery disconnecter is a safety device that cuts off the power supplied to the electrical system, thus shutting off the connection between the battery and the users.

The purpose of this is to:

- prevent the battery from discharging itself too much when the tractor is not used for a long time;
- provide protection if the electrical system short-circuits;
- allow servicing work or repairs to be carried out in safe conditions.

The battery disconnecter is installed on the left-hand side of the engine and can be accessed by raising the bonnet. The switch has three positions:

- Switch in the "ON" position: electrical system powered (Fig. 5.13);
- The switch is set to the "OFF" position by turning it 1/4 of a turn in the anti-clockwise direction: electrical system not powered (Fig. 5.14);
- The switch releases and can be removed when turned again in the anti-clockwise direction (Fig. 5.15).

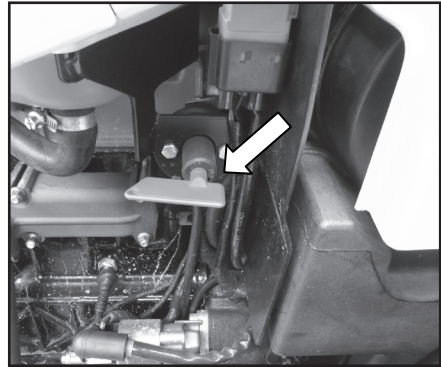

Fig. 5.13

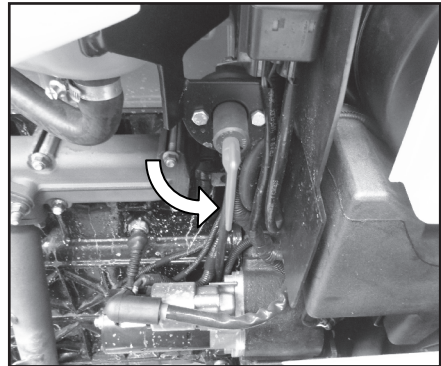

Fig. 5.14

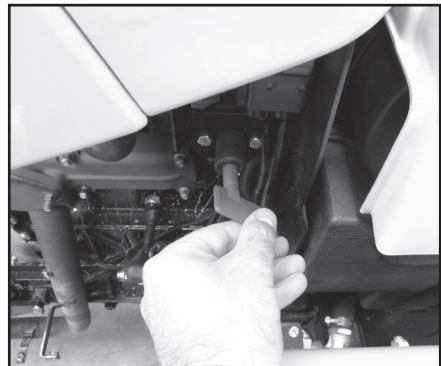

Fig. 5.15

Section 11 : Clutch pedal

The engine-gearbox clutch is a hydraulically-actuated, oil-immersed, multi-plate clutch. The pedal (1) engages/disengages the clutch:

- fully pressed pedal = disengaged clutch
- released pedal = engaged clutch

When the engine is carrying a load, avoid slipping the clutch to increase the rpm; instead, engage a lower gear.

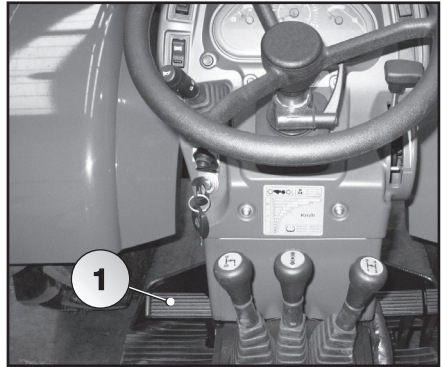

Fig. 5.16

⚠ Warning:

Never leave your foot on the clutch pedal.

Note:

A safety device prevents the engine from being started if the clutch pedal is not pressed down completely.

Section 12 : Transmission levers

12.1 Range lever

The lever (2) allows four different ranges to be selected for each of the speeds selected with the gearshift lever (4). Each range is indicated by a roman numeral on the lever handgrip (2):

- I - slow range
- II - normal range
- III - fast range

To move from one range to another, the engine clutch must be disengaged by pressing the pedal (1) down completely, the tractor must be stopped and the desired range must be selected using the relative lever (2).

 Warning:
Never attempt to change ranges while the tractor is moving.

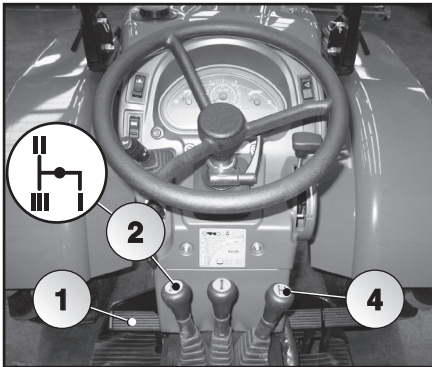



Fig. 5.17

12.2 Reverser lever

This lever (3) allows the tractor forward direction to be selected. The forward and reverse gears have synchronized engagement. To engage them, the engine clutch must be disengaged by pressing the pedal (1) down completely and the tractor must be stopped. This will safeguard the lifetime of the synchronizers.

 Warning:
Never attempt to change the direction while the tractor is moving.

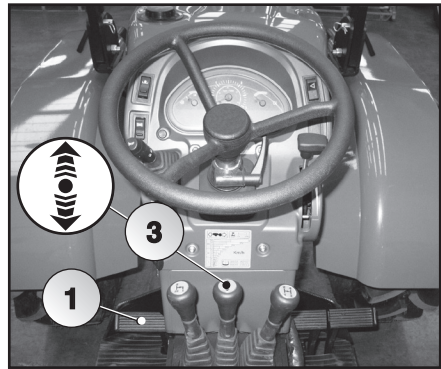

Fig. 5.18

12.3 Gearshift lever

This lever (4) allows 4 totally synchronized speeds to be selected, both forward and in reverse.

To move from one gear to another of the same range, press the clutch pedal (1) down completely and use the lever (4). Each gear is indicated by a roman numeral on the lever handgrip (4):

1. - first gear
2. - second gear
3. - third gear
4. - fourth gear

The decal (123) just under the steering wheel on the right indicates the perfect progressions of the gears without speed overlapping both in forward and reverse, with the indicated tires and engine rpm (Fig. 5.20 and Fig. 5.21).

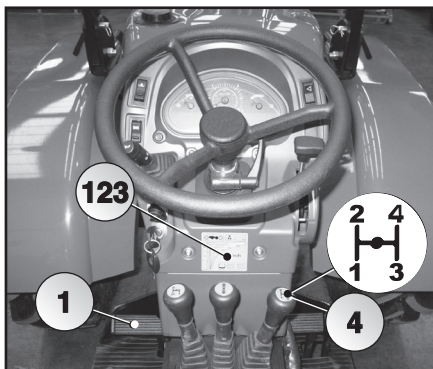

Fig. 5.19

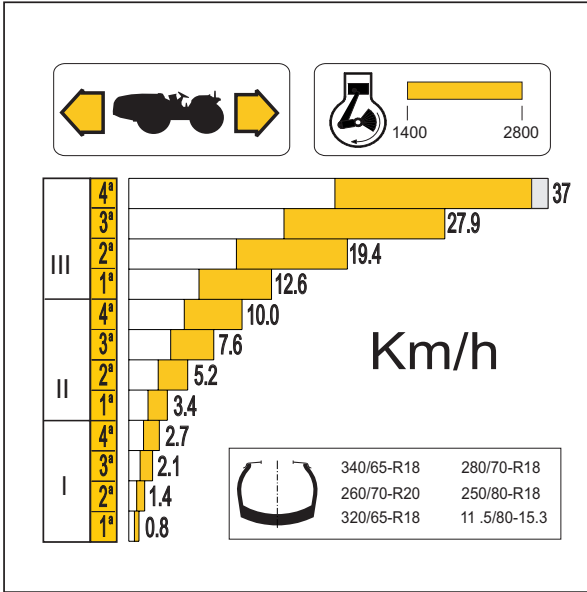

Fig. 5.20

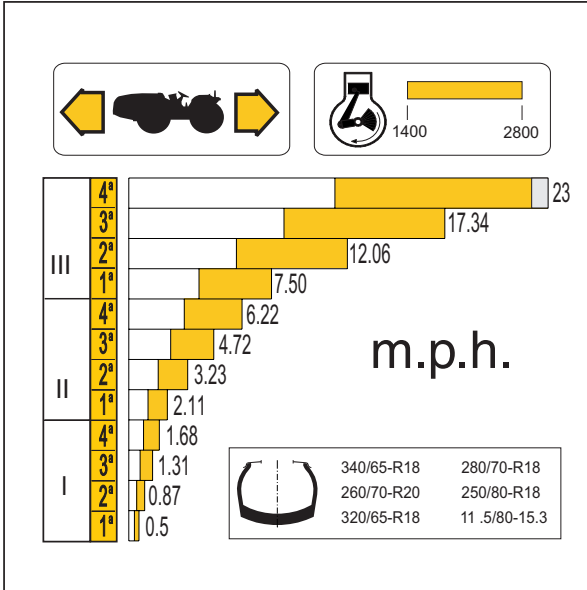

Fig. 5.21

Section 13 : Service and parking brakes

The **service brakes** on the four wheels are multi-plate and mechanically controlled.

In the AR model, tractor braking occurs by means of one pedal (6).

In the RS model, tractor braking occurs by means of two pedals (5) that separately control the brake of each rear wheel. Braking with only one pedal permits sharper turns. In fact, by locking the internal rear wheel at a curve, the tractor turns by pivoting on the wheel itself.

The simultaneous action of the brakes during normal use and on roads is done by locking the two pedals with the lockbolt (124).

In reverse, the RS version has only one brake pedal.

Warning:

When driving on roads, always keep the brake pedals coupled to ensure simultaneous braking on all four wheels. Never use the pedals independently when driving on roads.

Warning:

When the brakes feel loose, immediately identify the cause and eliminate the defect.

Warning:

When working in hilly areas, brake for the shortest necessary time only and always use the engine brake by inserting a low gear.

Warning:

When driving the tractor in the reversed position, the brake pedals must be coupled when in use.

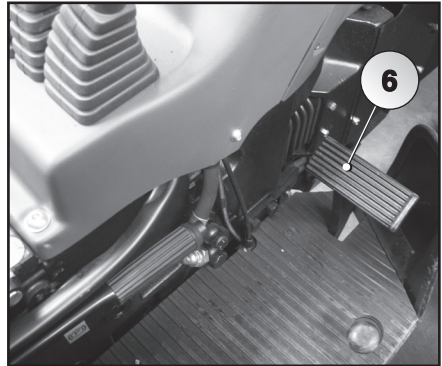

Fig. 5.22

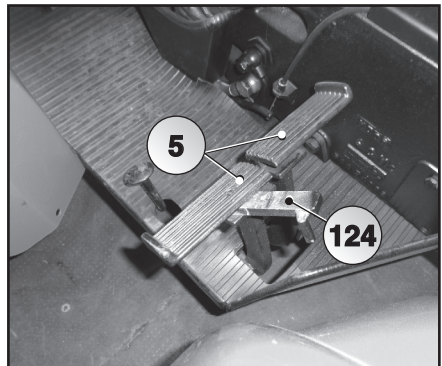
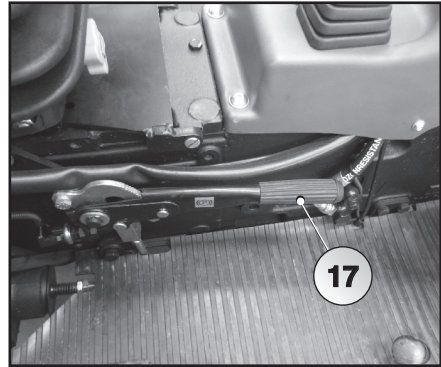
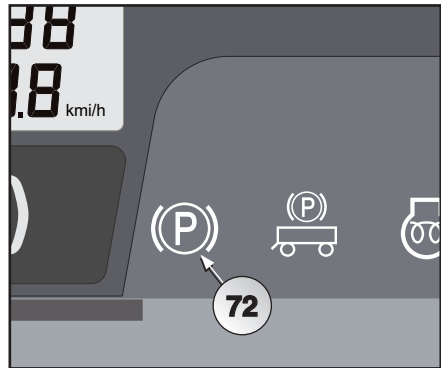

Fig. 5.23

The parking brake is controlled mechanically by a lever (17) positioned on the right side in the unidirectional version, on the left side in the reversible version.

When pulled upwards, the parking/emergency brake is applied. To lower this lever, release it first by pulling it up slightly and depressing the button on the end.

A red light (72) lights up on the instrument when the parking brake is engaged.

**Fig. 5.24****Fig. 5.25**

Section 14 : Controls on the dashboard

The **ignition switch** (11) has three positions:

- Pos.0 - No circuit is powered except for the flashing indicator lights switch engine off position; key may be remove.
- Pos.1 - Contact position, various users are powered and indicators and control instruments function; the engine is prepared for starting.
- Pos.2 - Engine starting position; if released, the key automatically returns to contact position 1.

The **lights switch and horn** (10) is just under the steering wheel on the left. It works with the ignition switch in contact position 1 and carries out the following functions:

- to the right - right turn signal
- to the left - left turn signal
- pressed - horn (functions regardless of the ignition switch position)

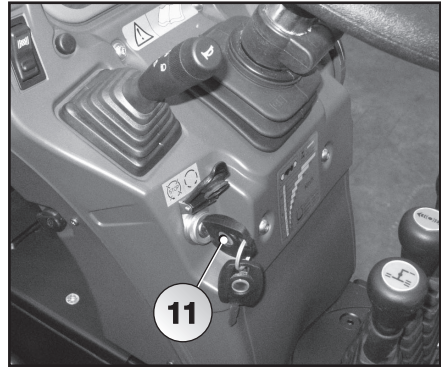

Fig. 5.26

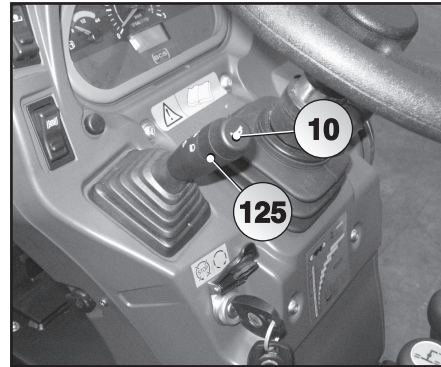

Fig. 5.27

The lights are activated by rotating the knob (125) on the end of the switch:

- ☐ Lights off

Rotating the switch (in a counter-clockwise direction the following light up in sequence:

- ☞☞☞ Position lights on and light (79) on instrument panel on;
- ☞☞☞ dipped headlights;
- ☞☞☞ when the switch is pushed downwards, the full beam headlights, (78). When the switch is pushed upwards, the full beam headlights flash.

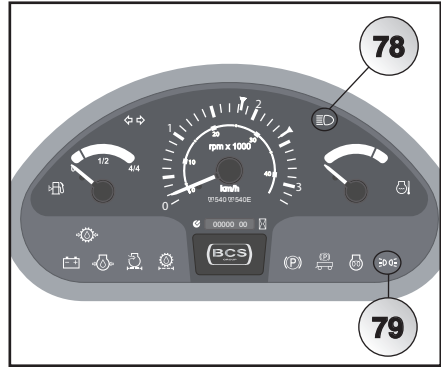

Fig. 5.28

The **hazard lights switch** (15) is always powered regardless of the ignition switch position.

If pressed, all of the indicator lights, the light of the switch itself, and the light (84) on the instrument panel blink intermittently.

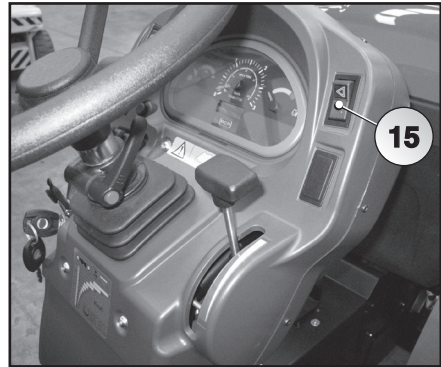

Fig. 5.29

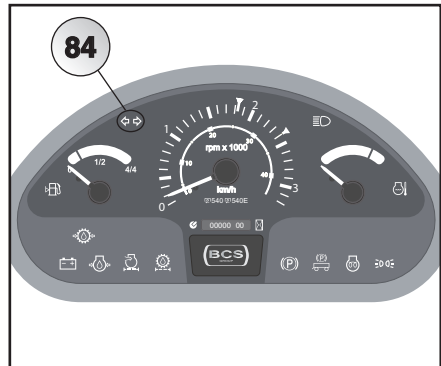

Fig. 5.30

Section 15 : Power Take-Off

The rear PTO may be "independent" or "synchronized" and it is engaged by means of a hydraulically-actuated, oil-immersed, multi-plate clutch. Engagement and disengagement is electrohydraulic. The speed of the PTO synchronized with the gearbox is proportional to the tractor speed.

⚠ Caution:

To prevent damage to the PTO braking system when pulling trailers, the PTO engagement button (12 Fig. 5.34) must be activated and/or kept activated, even if the PTO itself is not used. In this case, to prevent rotation of the PTO output shaft, the lever (27 Fig. 5.32) must be placed in neutral.

The shafts of the power take-off and the implements activated by the power takeoff should therefore be used, along with common sense:

⚠ Warning:

Do NOT drive without the PTO cap (111) or guard (110) assembled. They protect personnel from injury and the shaft grooves from damage.

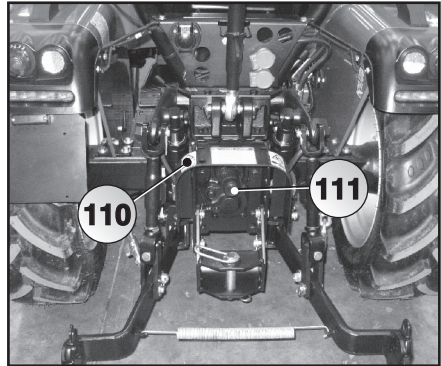

Fig. 5.31

 Warning:

Always disengage the Power Take-Off, turn off the engine, remove the key from the panel and activate the parking brake before getting off the tractor.

 Warning:

Keep well away from the machine until all its components, including the driveline, have stopped.

 Warning:

Before connecting, adjusting or working on implements operated by the PTO, disengage the PTO, turn off the engine, remove the key from the panel and activate the parking brake. Do not work under raised implements.

 Warning:

Make sure that all of the implements activated by the PTO have the proper guards installed, are in good condition and conform with current regulations.

 Warning:

Before starting an implement connected to the PTO, ALWAYS make sure that people are at a safe distance.

 Warning:

Attach the drawbar in the central position when using implements operated by the tractor PTO.

 Warning:

When using the PTO while the tractor is parked, ALWAYS make sure that the ranges lever is in the neutral position, the reversing gear lever is in the forward position, the gears lever is engaged in the 4th gear and the parking brake is engaged.

 Caution:

When choosing a universal joint, it's necessary to make an assessment based on the connection between the tractor and machine on which it will be assembled (shaft dimensions), the power takeoff speed, tractor's HP, the need to insert special joints, clutches, uncouplers. Also, take into consideration the largest permissible angle, which must not be exceeded. For this aspect, comply with the manufacturer's operating features.

 Caution:

Make sure that the length of the universal shaft falls within the manufacturer's tolerances and that it is able to compensate the movements of the machine during movement.

 Warning:

Before operating an implement activated by the PTO on the three-point hitch, carefully raise it using the position control lever to maximum height, check for play and make sure that at least 1/4 of the length of the telescopic section of the drive shaft is engaged.

P.T.O. levers

The independent or synchronised PTO must be selected, by means of the lever (27), while the engine is being turned off, before it comes to a complete standstill. In this way the internal selection organs can find the right alignment.

When the position has been selected, the lever (27) can be left always engaged, because the PTO can be engaged or disengaged by means of the button (12) on the dashboard.

Note:
Before engaging the PTO clutch using the switch (12), the type of operation, independent or synchronized, must be chosen using the lever (27).

 Warning:
Engage the PTO at a low rpm to protect the clutch and drive shaft.

Before engaging the PTO, select the type of operation. The lever (27) to the left of the operator position selects the type of PTO:

- **independent**, where the PTO output shaft receives motion directly from the engine. In fact, its rotation speed is proportional to the engine's speed. Clockwise direction of rotation;
- **synchronized**, where the speed of the PTO output shaft is proportional to the tractor forward speed. Counter-clockwise rotation in forward mode.
- Lever (27) toward A - independent PTO engaged
- Lever (27) in center position N - PTO in "neutral"
- Lever (27) toward B - synchronized PTO engaged

 Warning:
High inertia implements will not immediately stop after the PTO is disengaged. Wait for the implement to slow down and stop completely before cleaning or making adjustments.

To engage the PTO clutch, move the safety bar (112) to the side and press the switch (12). When the switch is pressed, the relative light inside the switch itself comes on.

Note:
Before switching off the engine, disengage the PTO clutch using the switch (12).
If the engine is started while the switch (12) is armed, in order to engage the PDF clutch, it is necessary to rearm the PTO clutch engagement switch and restart the engine.

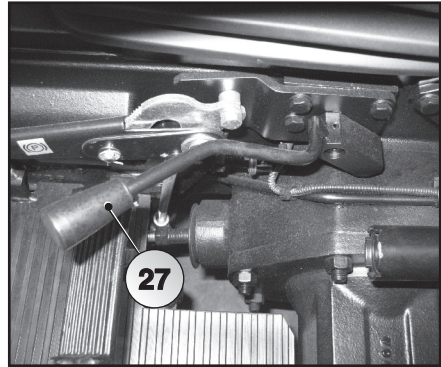

Fig. 5.32

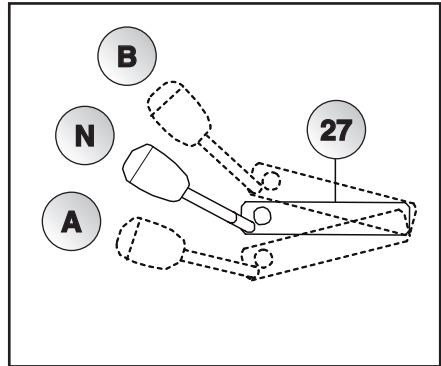

Fig. 5.33

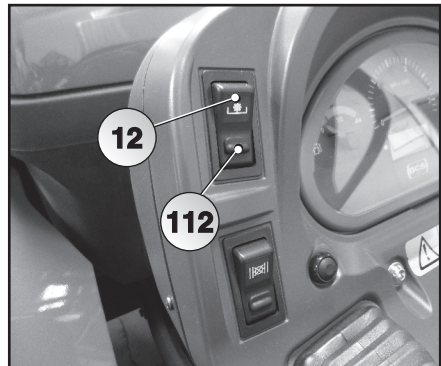

Fig. 5.34

Using the independent PTO

⚠ Warning:

Do not connect implements or machine tools that require higher power than that provided by the PTO.

- 1 - Select "independent" operation by placing the lever (28) in position A;
- 2 - Move the safety bar (112) to the side and press the PTO clutch engagement switch (12). The light inside the switch will turn on;
- 3 - (digital instrument panel). Control the engine rpm so that the instrument display shows the selected PTO speed.

The independent PTO receives motion directly from the engine and its operation is independent from the tractor speed.

To stop the independent PTO, press the switch (12); the light inside the switch will turn off.

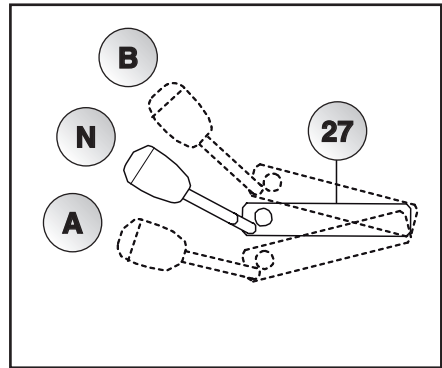

Fig. 5.35

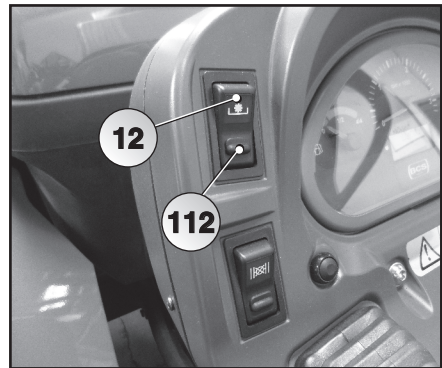

Fig. 5.36

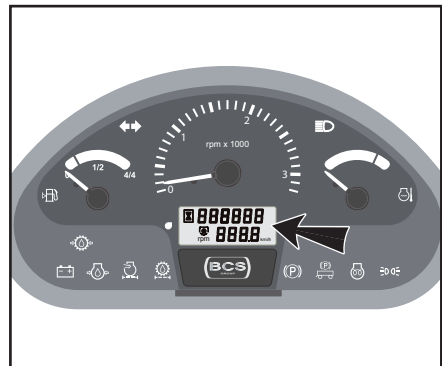

Fig. 5.37

Using the synchronized PTO

⚠ Warning:

When using the synchronized PTO, if one or more reverse operations must be carried out, remember that the shaft's rotation direction will be inverted. Thus, with certain implements, it is advisable to disengage the selector lever of the independent/synchronised PTO (27) and let only the PTO engagement button (12) to be active to avoid damages to rotating organs as well as to PTO braking system.

Use of the PTO synchronized with the gearshift is only necessary for operating self-propelled trailers and, in general, for all agricultural implements that require synchronization with tractor advancement; they must not absorb more than 40-45% of the maximum engine power.

To engage the synchronized PTO:

- 1 - Make sure that the tractor is at a standstill;
- 2 - Select "synchronized" by placing the lever (27) in position B;

The synchronized PTO receives motion directly from the gearbox; the rotation speed of the PTO shaft is therefore proportional to the tractor speed.

To stop the synchronized PTO, place the PTO type lever (27) in "neutral".

With the synchronized PTO and any gear engaged, the PTO grooved shaft carries out 6,634 revolutions for every revolution of the rear wheels:

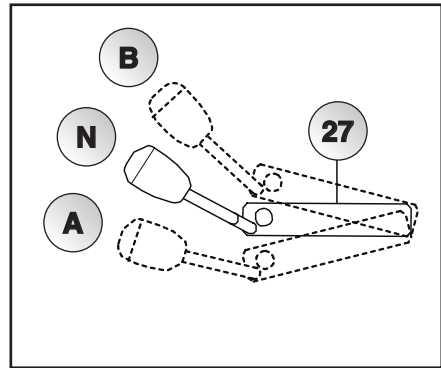

Fig. 5.38

Section 165: Differential lock

The tractor is equipped with a front and rear differential lock, which should be engaged when a wheel slips due to a lack of traction.

Warning:

Use the differential lock only when the tractor proceeds straight and when traction is unstable. Do not turn with the differentials locked.

Warning:

Disengage the lock when making turns.

To lock the rear differential:

- 1 - Decrease the tractor speed;
- 2 - Move the safety bar (112) downwards and press the switch (13).

Locking of the rear differential is indicated by a light inside the switch (13) itself that comes on.

To release the differentials:

- press the switch (13).

The disengagement of the differential locking mechanism is signalled by the switching off of the warning light incorporated in the switch (13) itself.

Note:

For best results, lock the differential before excessive slipping occurs. Do not engage it while a wheel is slipping excessively.

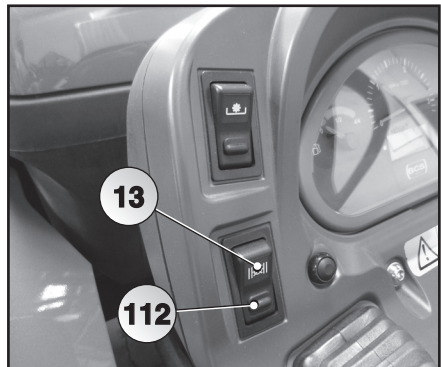

Fig. 5.39

Section 17: Hitch

Front hitch

The tractor is equipped with a front hitch (127) to perform emergency trailer maneuvers or to tow the tractor.

⚠ Caution:

The front hitch must be used exclusively for emergency towing of the tractor. The towing direction must coincide with the longitudinal axis of the tractor itself.

The tractor may not be towed in other directions that do not correspond to this axis or for purposes other than those described.

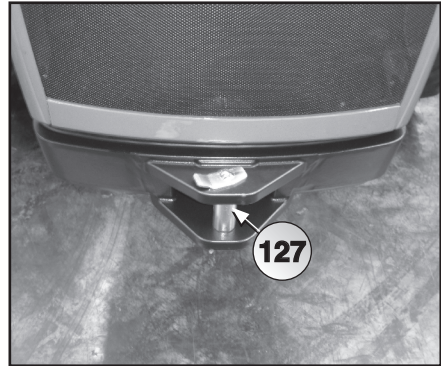

Fig. 5.40

Rear hitch

Depending on the type-approvals and regulations in individual countries, the following types of rear hitches are available:

- Cat.C hitch, approved for Italy (128)
- hitch approved for Europe (129)

These hitches can be used for farming implements and one or two-axle road trailers.

To facilitate hitching of the implement, the height of these devices can be adjusted to various positions using safety pins and rods.

The various heights from the ground are shown in Fig. 5.45 and Fig. 5.46.

To adjust the height, remove the connection pins (130) to free the hitch and secure it in the desired position.

Note:

Adjustment of the hitches is an operation that must be carried out carefully because proper hitch adjustment affects, in fact, the ease of handling of the tractor and, most of all, safety and stability during operation.

Note:

The hitch placed in the highest position makes towing easier but also increases the risk of the tractor rearing up.

Note:

With four-wheel drive, place the hitch in the low position, keeping the tongue nearly horizontal so that not too much weight is removed from the front axle.

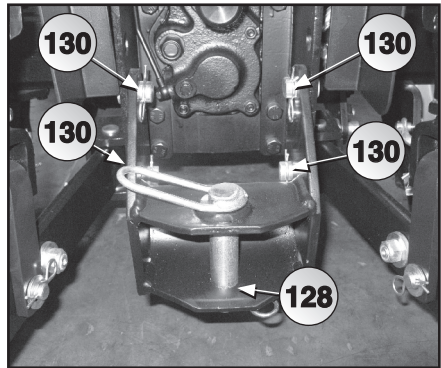

Fig. 5.41

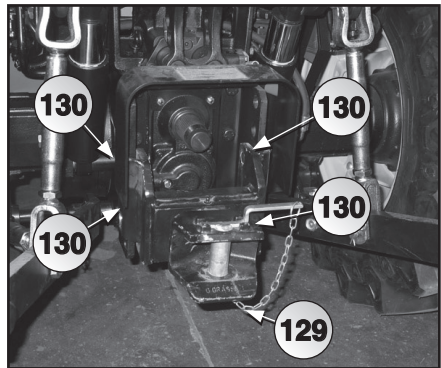

Fig. 5.42

Towing trailers

The braking system of the trailer is mechanical.

When a trailer is towed, the special hand brake system must be applied onto the tractor.

- Introduce the trailer hand brake lever into the provided housing (131) on the right of the tractor platform;
- Connect the trailer electrical circuit to the tractor's using the provided 7-pin outlet (28).

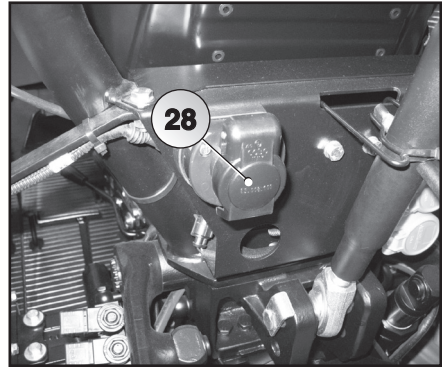

Fig. 5.43

⚠ Caution:

Remove the ignition key before making the electrical connections/disconnections.

NOTE:

Do not drive at a speed above 30 Km/h when towing a trailer.

Note:

If the trailer that must be towed has driving wheels, the hitch must be positioned so that the power take-off is free and the cardan joint that connects the trailer can be installed.

Note:

To prevent damage to the PTO braking system when pulling trailers, the PTO engagement button (12 Fig. 5.34) must be activated and/or kept activated, even if the PTO itself is not used. In this case, to prevent rotation of the PTO output shaft, the lever (27 Fig. 5.32) must be placed in neutral.

⚠ Danger:

It is strictly forbidden to remain in the area between the tractor and the towed vehicle as the engine will be running; and also without securely parking the tractor, using if necessary (on sloping or uneven ground) blocks under the wheels and steering crossways to the slope.

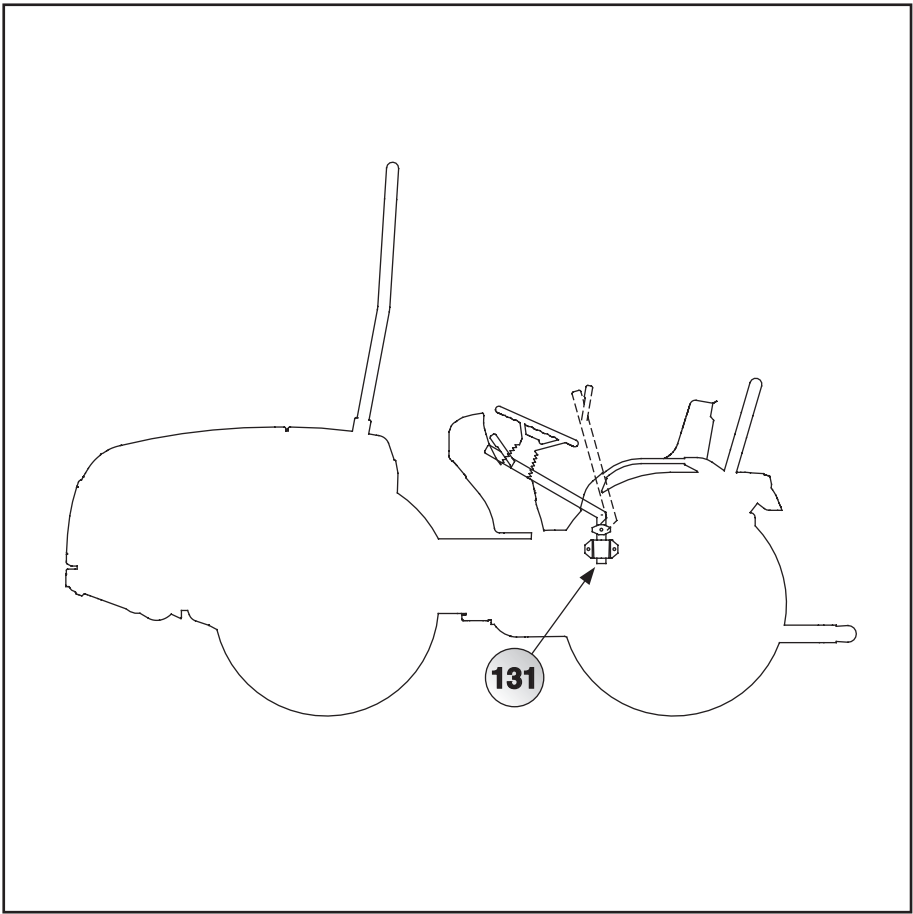

Fig. 5.44

USER REGULATIONS

Hitch approved for Italy

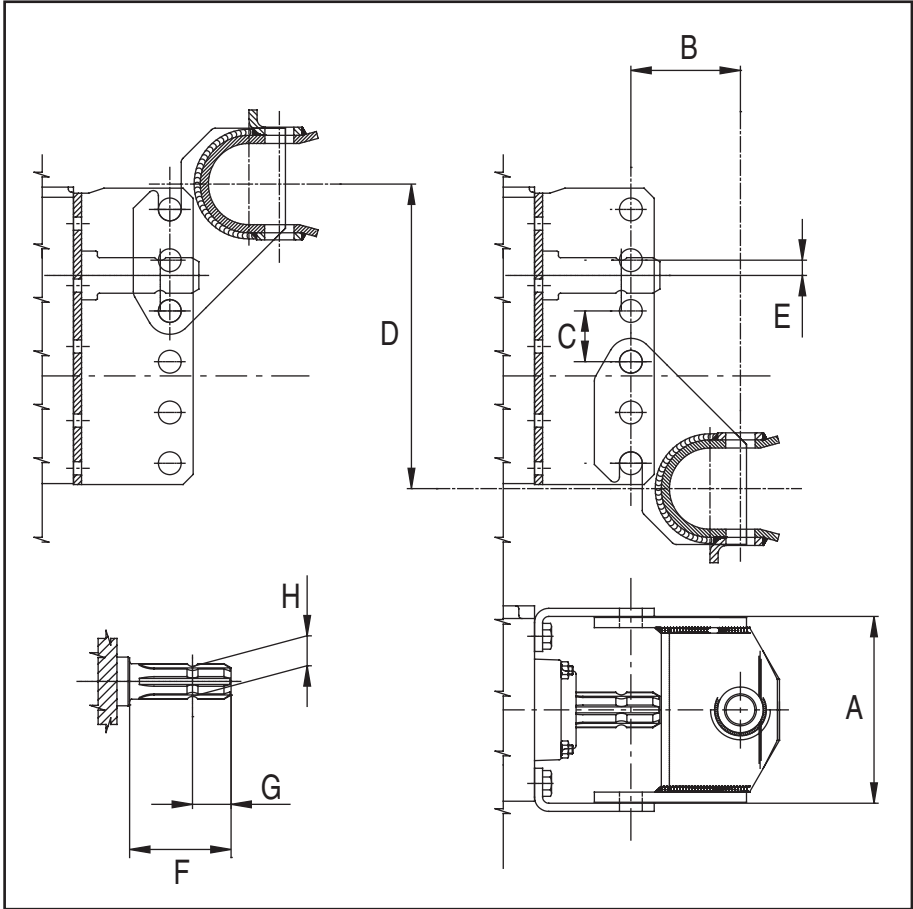

Fig. 5.45

	A	B	C	D	E	F	G	H
mm	184	108	50	300	15	95	38	29.5
inches	7.22	4.24	1.96	11.76	0.59	3.73	1.49	1.16

Hitch approved for Europe

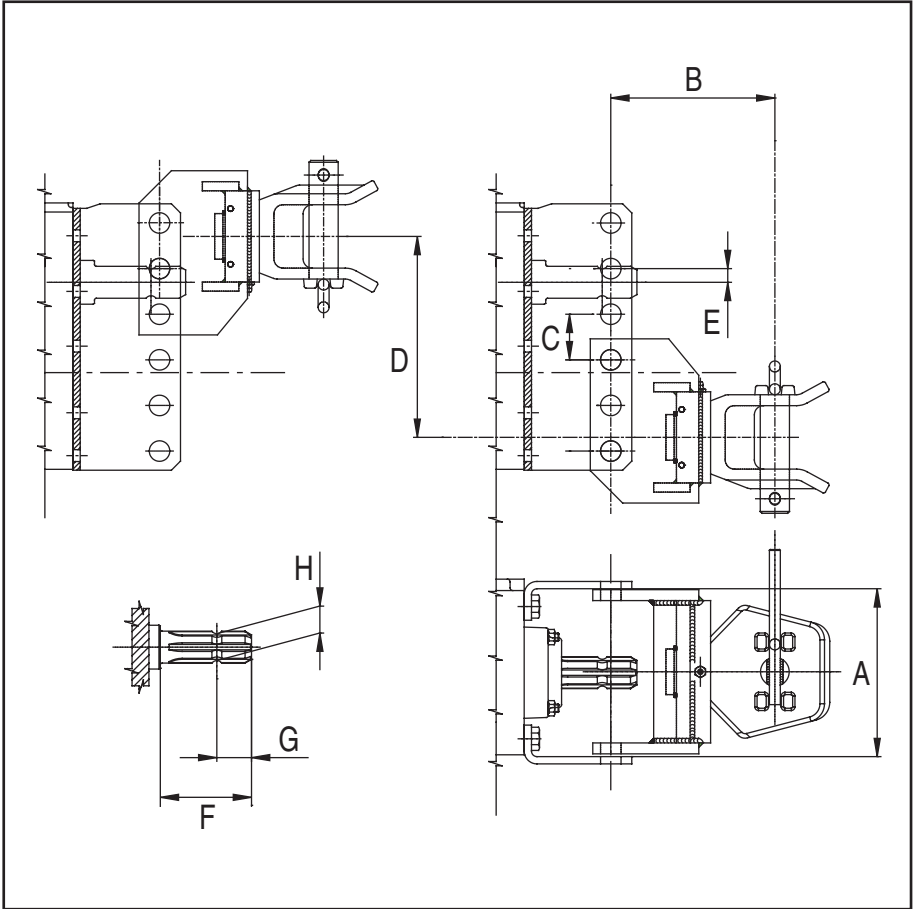

Fig. 5.46

	A	B	C	D	E	F	G	H
mm	184	180	50	270	15	95	38	29.5
inches	7.22	7.06	1.96	10.59	0.59	3.73	1.49	1.16

USER REGULATIONS

17.1 Maximum vertical load on Rear coupling - “RS” version

Tyres Front and rear axes	Capacities (kg/Axle)	Vertical load on couplers			
		COUPLER "GRASSI e11 1572"			
		Sz	Cz1	Cz2	Cz3
11.5/80-15.3 (10 PR)	1580	760	690	800	730
260/70 R20 (113 A8)					
300/65 R18 (116 A8)					
320/65 R18 (109 A8)					
280/70 R18 (114 A8)					
210/95 R18					
33x12.50-15 (6PR)					
33x15.50-15 (6PR)					
31x15.50-15 (4PR)					
31x13.50-15 (4PR)					
260/70-16 (109 A8)					
10.0/75-15.3					
29x12.50-15 (4PR)					
7.50-16 (8PR)	1430	650	580	690	620
8.25-16 (6PR)	1380	610	550	650	580
7.50-18 (8PR)					
250/80-18 (8PR)	1340	580	520	620	550

- Sz:** Without ballasts
- Cz1:** Ballasts on wheels
- Cz2:** Side ballasts
- Cz3:** Side ballasts + on wheels ballasts

Tyres Front and rear axes	Capacities (kg/Axle)	Vertical load on couplers			
		COUPLER "BCS DGM*6*0031GA"			
		Sz	Cz1	Cz2	Cz3
11.5/80-15.3 (10 PR)	1580	500	500	500	500
260/70 R20 (113 A8)					
300/65 R18 (116 A8)					
320/65 R18 (109 A8)					
280/70 R18 (114 A8)					
210/95 R18					
33x12.50-15 (6PR)					
33x15.50-15 (6PR)					
31x15.50-15 (4PR)					
31x13.50-15 (4PR)					
260/70-16 (109 A8)					
10.0/75-15.3					
29x12.50-15 (4PR)					
7.50-16 (8PR)	1430				
8.25-16 (6PR)	1380				
7.50-18 (8PR)					
250/80-18 (8PR)	1340				

- Sz:** Without ballasts
Cz1: Ballasts on wheels
Cz2: Side ballasts
Cz3: Side ballasts + on wheels ballasts

USER REGULATIONS

17.2 Maximum vertical load on Rear coupling - “AR” version

Tyres Front and rear axes	Capacities (kg/Axle)	Vertical load on couplers			
		COUPLER "GRASSI e11 1572"			
		Sz	Cz1	Cz2	Cz3
11.5/80-15.3 (10 PR)	1300	550	490	590	520
260/70 R20 (113 A8)					
300/65 R18 (116 A8)					
320/65 R18 (109 A8)					
280/70 R18 (114 A8)					
210/95 R18					
33x12.50-15 (6PR)					
33x15.50-15 (6PR)					
31x15.50-15 (4PR)					
31x13.50-15 (4PR)					
260/70-16 (109 A8)					
10.0/75-15.3					
29x12.50-15 (4PR)					
7.50-16 (8PR)					
8.25-16 (6PR)					
7.50-18 (8PR)					
250/80-18 (8PR)					

- Sz:** Without ballasts
- Cz1:** Ballasts on wheels
- Cz2:** Side ballasts
- Cz3:** Side ballasts + on wheels ballasts

Tyres Front and rear axes	Capacities (kg/Axle)	Vertical load on couplers			
		COUPLER "BCS DGM*6*0031GA"			
		Sz	Cz1	Cz2	Cz3
11.5/80-15.3 (10 PR)	1300	500	500	500	500
260/70 R20 (113 A8)					
300/65 R18 (116 A8)					
320/65 R18 (109 A8)					
280/70 R18 (114 A8)					
210/95 R18					
33x12.50-15 (6PR)					
33x15.50-15 (6PR)					
31x15.50-15 (4PR)					
31x13.50-15 (4PR)					
260/70-16 (109 A8)					
10.0/75-15.3					
29x12.50-15 (4PR)					
7.50-16 (8PR)					
8.25-16 (6PR)					
7.50-18 (8PR)					
250/80-18 (8PR)					

- Sz:** Without ballasts
Cz1: Ballasts on wheels
Cz2: Side ballasts
Cz3: Side ballasts + on wheels ballasts

Section 18 : Three-point hitch

The three-point hitch is used to connect category I implements with standard dimensions and characteristics, controlled by the hydraulic lift, to the tractor.

Warning:

Always be very careful when using and adjusting the three-point hitch.

For proper operation of the lift, the dimensions of the implement to be attached to the tractor must be checked carefully.

These hitches must have the same standard as the tractor three-point hitch to prevent irregular stress on the unit due to incompatibility of the dimensions.

Implements must be lower than the maximum load that can be lifted. This is Only an approximate value; the distance of the center of gravity of the implement in relation to the three-point hitch is also very important.

In fact, if an implement is placed too far from the tractor, the weight on the three-point hitch will be considerably greater than the weight of the implement itself.

Warning:

Always turn off the engine and remove the ignition key before making any adjustments to the three-point hitch or the implement.

Warning:

Always use the lift in the control position when implements are moved using the three-point hitch.

Warning:

Always use the lift in the control position when connecting or removing an implement of the three-point hitch.

Caution:

Before leaving the tractor always lower equipment connected to the three-point coupling to ground level.

Warning:

Never work under an implement raised solely by the hydraulic lift; instead, always use a suitable support to hold it in place and turn off the engine.

Danger:

To prevent injuries to persons, never remain between the equipment and tractor whilst operating the three-point coupling.

Caution:

Generally, with the equipment connected to the three-point coupling, the universal joint has a reduced extension and the articulation angle is almost equal. With the equipment raised the shaft is at its maximum extension and diversification of its articulation angle. Therefore for high lifting heights it may therefore be necessary to stop the rotation.

The three-point hitch basically consists of the following parts:

- 1 - a top link (132) hinged to the tractor body, with a sleeve for adjusting the length;
- 2 - two lateral stabilizers (134) that prevent transversal shaking of the hitch;
- 3 - two lower tie rods (135) hinged to the tractor body;
- 4 - two vertical tie rods (137) with adjustable height, which connect the lower tie rods to the lift arms.

The lower tie rods transmit the necessary pull and support to the implement. They have fixed ball joints or quick hitches on the ends.

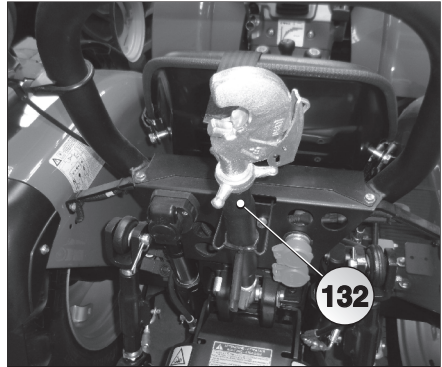

Fig. 5.47

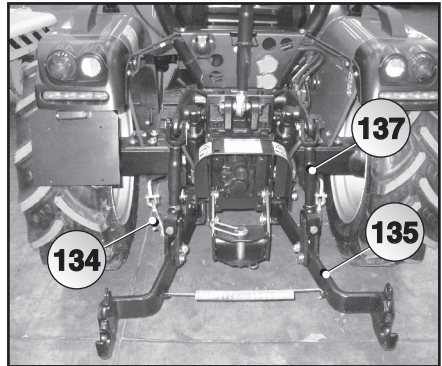

Fig. 5.48

Vertical tie rods

The height of the vertical tie rods (137) can be adjusted using the handles provided (140). This adjustment is very useful for leveling the implement according to the type of job.

Turn the fork clockwise to shorten the vertical tie rod.

Turn the fork counter-clockwise to lengthen the vertical tie rod.

After adjusting make sure that, with the lift at its highest point, the implement is not raised higher than necessary and, with the lift lowered, that the implement can travel lower.

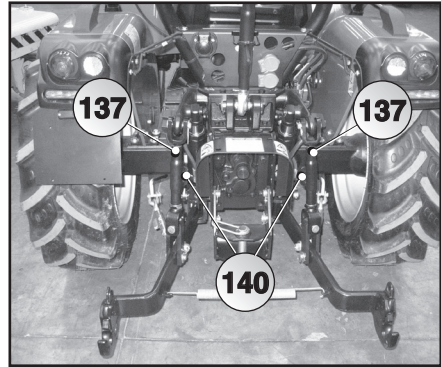
**Fig. 5.49**

Top link

The top adjustable link (132) is connected to the support by two holes. It must be selected based on the height of the implement.

The length of the top link may be varied so that the implement's angle of incidence can be adjusted in relation to the ground. When the top link is shortened, the incidence increases; when lengthened, the incidence decreases.

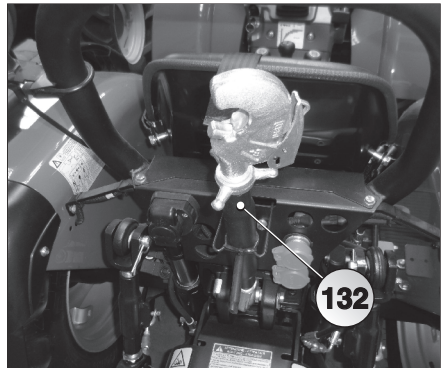

Fig. 5.50

Implement attachment to the tractor

⚠ Warning:

When attaching implements to the front and rear three-point linkage, the following values must not be exceeded:

- maximum total weight
- maximum axial load
- maximum load capacity of tyres

Load on front axle must always be 25% at least of the tractor's empty weight.

Before buying an implement, check accurately that the above requirements are met.

The tractor-implement assembly may be unstable owing to the weight of the machines: if the implements are too heavy for the tractor, they could lighten its front axle when they are hitched to the rear power lift, making the tractor difficult to drive and causing it to swerve round bends. Besides choosing the right tractor-implement combination, the remedy is to apply ballast, which must be done to suit the following conditions (Fig.5.51):

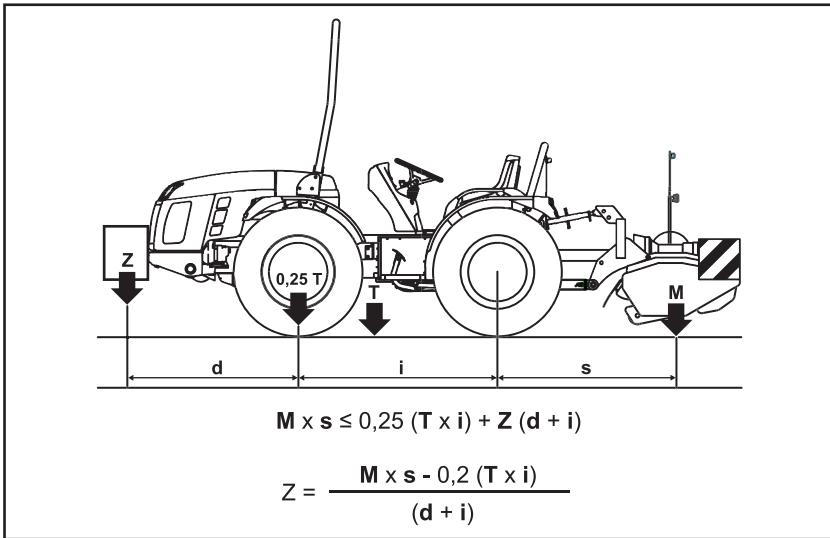

Fig. 5.51

Maximum permitted operating weights (kg)

Tyre	Front axle	Rear axle		Total
		RS	AR	
11.5/80-15.3 (10 PR)	1300	1580	1300	2300
260/70 R20 (113 A8)	1300	1580	1300	2300
300/65 R18 (116 A8)	1300	1580	1300	2300
320/65 R18 (109 A8)	1300	1580	1300	2300
280/70 R18 (114 A8)	1300	1580	1300	2300
210/95 R18	1300	1580	1300	2300
33x12.50-15 (6PR)	1300	1580	1300	2300
33x15.50-15 (6PR)	1300	1580	1300	2300
31x15.50-15 (4PR)	1300	1580	1300	2300
31x13.50-15 (4PR)	1300	1580	1300	2300
260/70-16 (109 A8)	1300	1580	1300	2300
10.0/75-15.3	1300	1580	1300	2300
29x12.50-15 (4PR)	1300	1580	1300	2300
7.50-16 (8PR)	1300	1430	1300	2300
8.25-16 (6PR)	1300	1380	1300	2300
7.50-18 (8PR)	1300	1380	1300	2300
250/80-18 (8PR)	1300	1340	1300	2300

Hitching points (mm) - AR model tractor (basic)

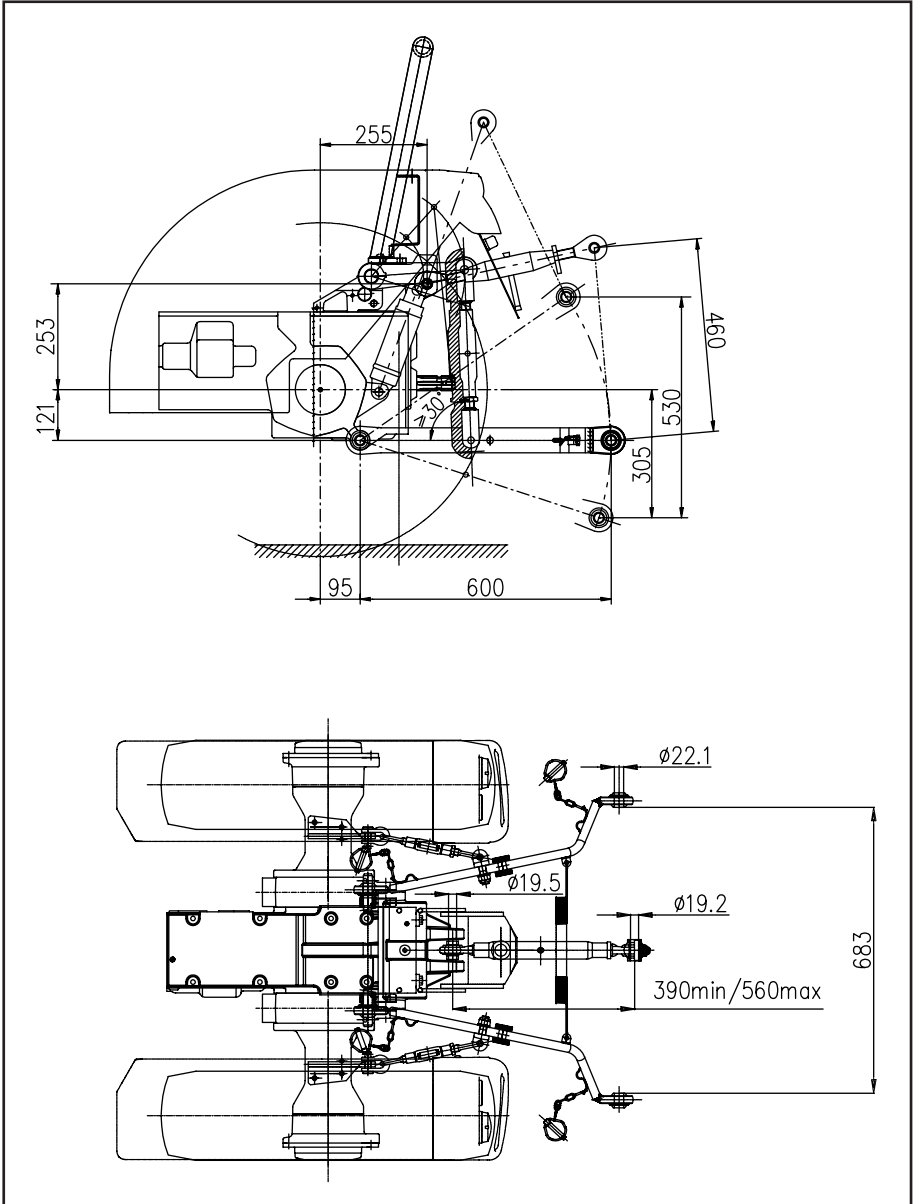

Fig. 5.52

USER REGULATIONS

Hitching points (mm) - AR - RS model tractor (basic)

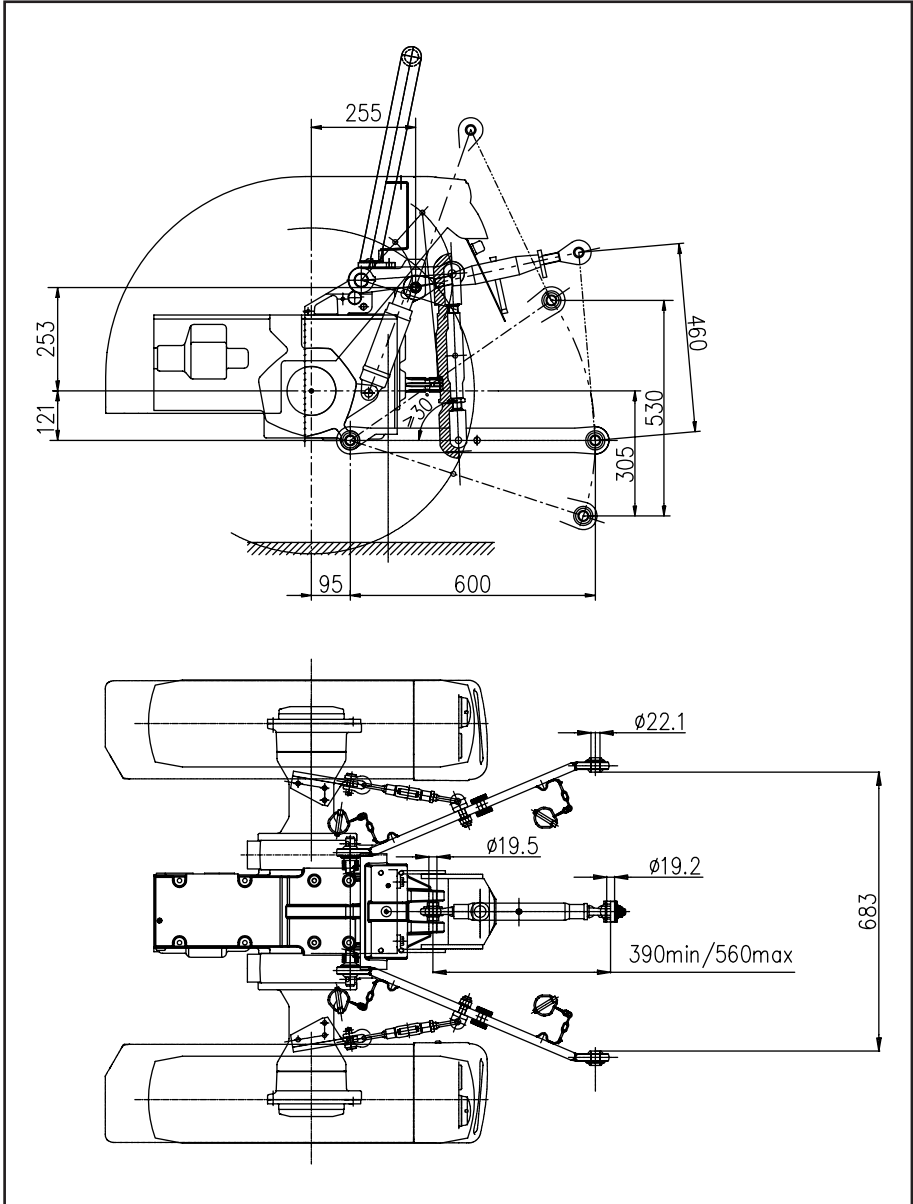
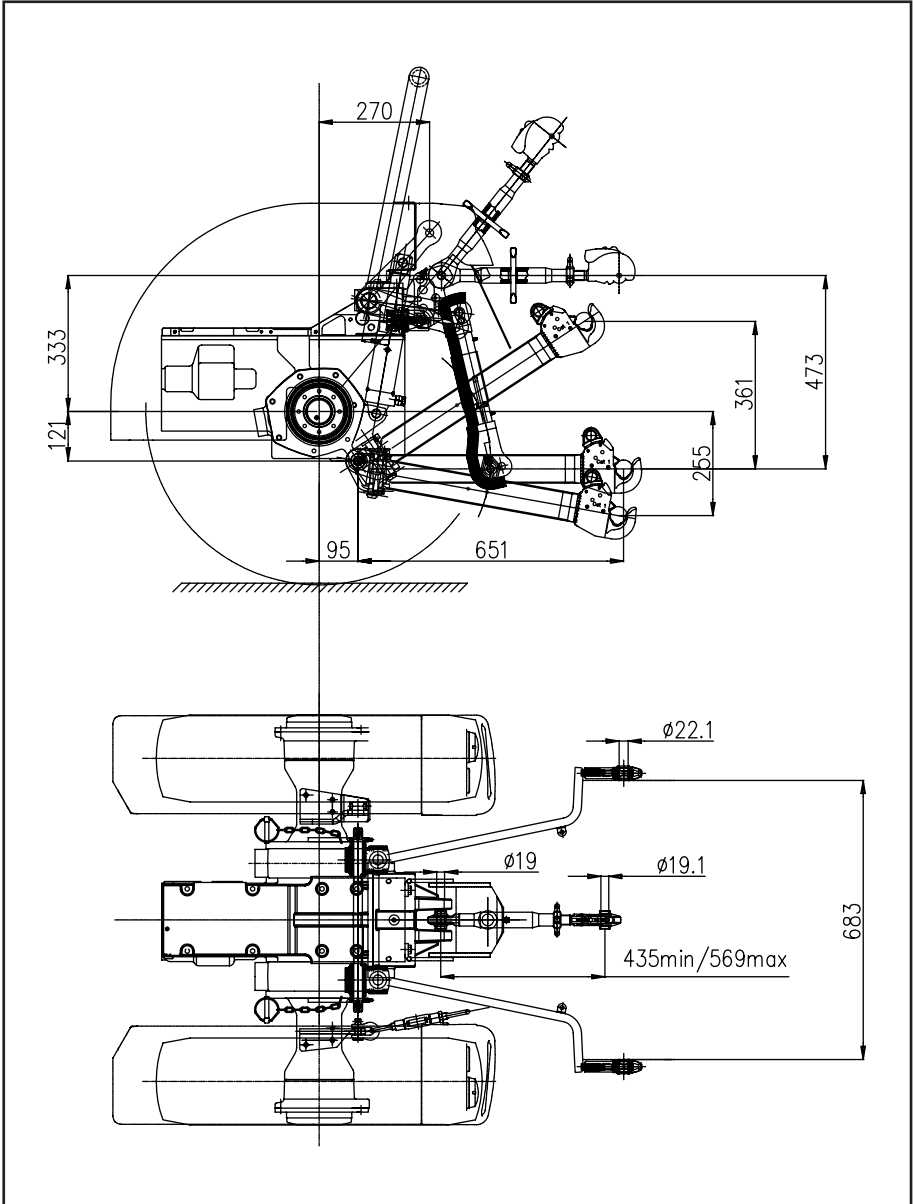

Fig. 5.53

Hitching points (mm) - AR - RS model tractor (optional)



USER REGULATIONS

Fig. 5.54

Hitching points (mm) - AR - RS model tractor (optional)

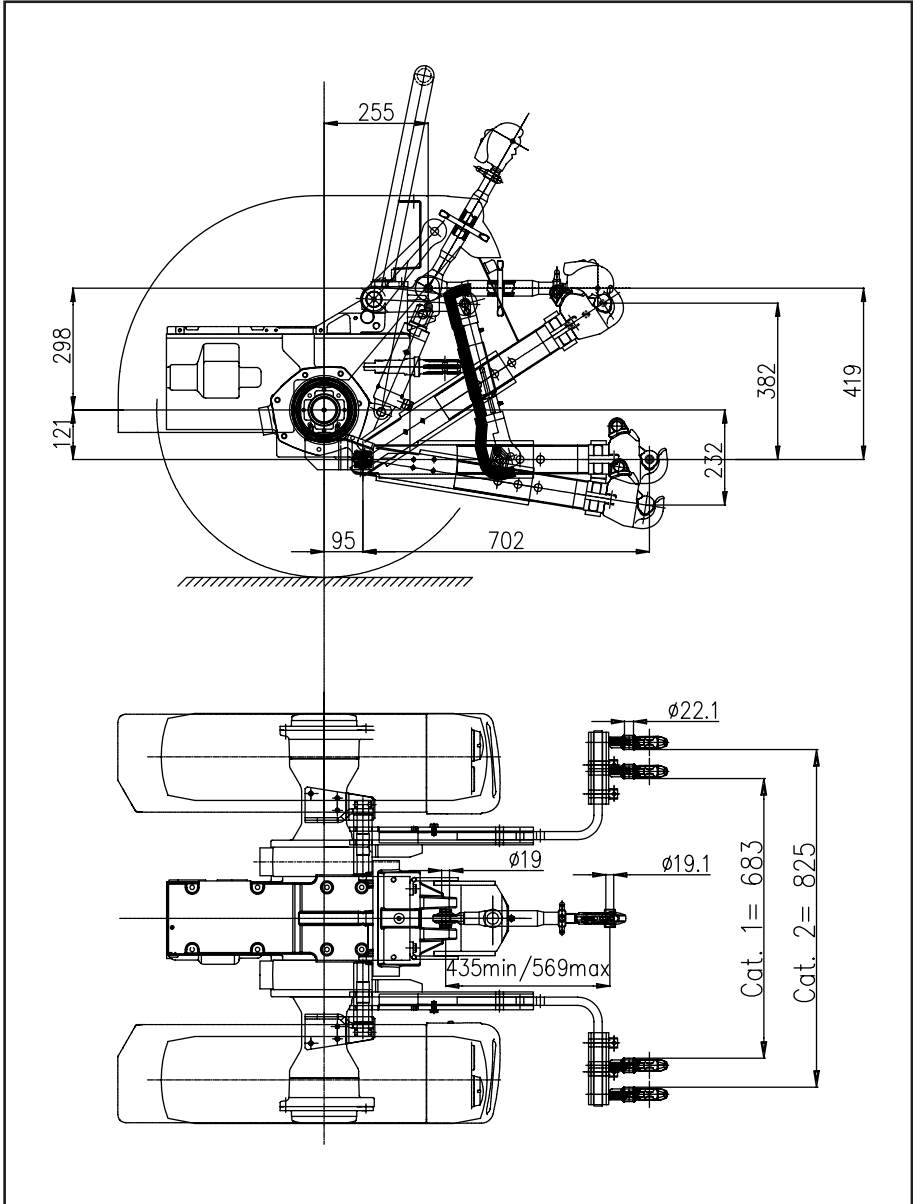

Fig. 5.55

18.1 Standard rear lift

The hydraulic lift raises and lowers the implements connected to the three-point hitch.

The position of the lift arms may be controlled using the lever (20), from completely raised to completely lowered.

- Lever (20) up - arms raised
- Lever (20) down - arms lowered

The lever (20) is on the right side of the operator seat..

It is possible to lock the lever (20) in the lowest position by pressing on the lever itself, thereby obtaining the free movement of the arms (floating function).

The knob (21) adjusts the lowering speed of the lift arms.

Turning it clockwise reduces the speed, while turning it counter-clockwise increases the speed.

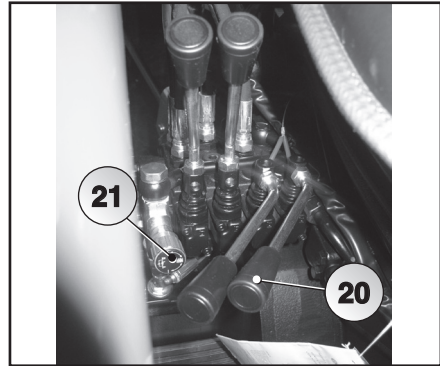

Fig. 5.56

Note:

During road transfer with implements connected, it is necessary to close the valve in order to prevent the implement from being lowered.

18.2 Rear lift with hydraulic suspension

The hydraulic lift can either operate normally as described on the previous page or, with the air of hydraulic suspension which allows controlled “floating” of the implement on the ground to be obtained using an nitrogen accumulator.

Note:

The accumulator pressure must never exceed 140 bar.

The “suspension” function is achieved with the flow switching lever (29).

If the flow switching lever (29) is moved towards the gearbox (pos. “B”) you have the “suspension” effect.

In this function, one cylinder works in combination with the accumulator and the other is used for lift functions.

Lever (30) connected to the hydraulic control valve, operates arm raising or lowering.

Lever (31) is used to charge or relieve the accumulator to the required pressure (based on the weight of the implement to be removed from the soil) and to keep circuit pressure steady. Accumulator pressure is shown on the pressure gauge (33).

When the flow switching lever (29) is moved towards the left mudguard (pos. “A”), both cylinders are used for lifting.

The levers (23) and (32) control respectively a double acting spool valve and a double acting spool valve with mechanical connection.

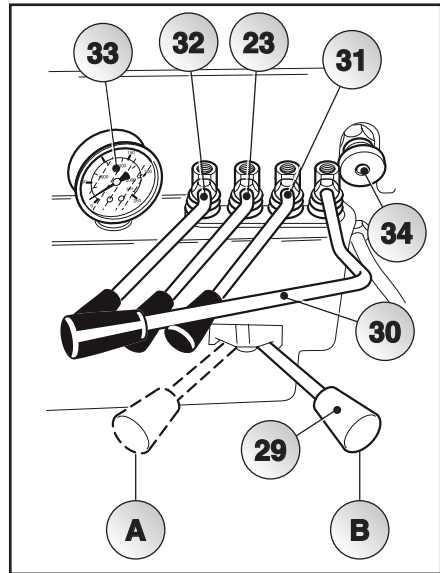

Fig. 5.57

Note:

The hydraulic circuit is, in any case, activated by the accumulator. The accumulator is also under pressure when the jacks are activated and therefore, when used, the jacks themselves slow down.

Note:

Once the accumulator has been charged to the required pressure, it is possible to raise and then lower the lift using the lever (30), maintaining the floating function of the implement.

18.3 Rear lift with position and draft control

The implement lift may be used in the following conditions:

- position control;
- controller draft;
- floating functio;
- combined position and draft control.

The lift may be used in various ways indicated above through combined use of the levers (24 and 25), position control and draft control, respectively.

The levers (24 and 25) are located to the right of the operator position, next to the seat.

The lever (24) controls the position of the arms. Each position of the lever corresponds to a position of the lift arms, from completely raised (lever all the way back) to completely lowered (lever all the way forward).

The lever (25) allows the implement to be placed in the ground at the desired depth.

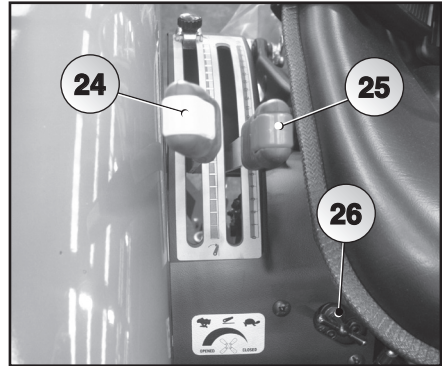

Fig. 5.58

Position control

Position control brings the implement to a certain position and keeps it there, whatever it may be, including the highest and lowest position, whether in or out of the ground.

Position control is used for:

- mounted implements, that is without wheels or other parts for resting on the ground;
- semi-mounted implements, that is with wheels or other parts for resting on the ground.

For this type of work:

- move the draft control lever (25) completely forward;
- move the position control lever (24) forward for lowering or backward for lifting.

Note:

The implement is moved proportionally to the position of the lever (24).

Draft control

Draft control of the lift consists of automatically keeping the tractor pull constant regardless of the varying work conditions.

Draft control is used with all mounted tractor implements without ground support like runners, wheels, etc.

For this type of work:

- move the position control lever (24) completely forward;
- gradually move the draft control lever (25) forward until the implement is placed in the ground at the desired depth;

Note:

The implement depth is proportional to the pull determined by the soil consistency. In this condition, the lift automatically keeps the pull required by the tractor constant.

- Raise the implement at the end of each pass using the position control lever (24).

Floating operation

Per ottenere questa modalità di lavoro:

- move the position control lever (24) and the draft control lever (25) completely forward;
- lower and raise the implement at the beginning and end of each pass using the position control lever (24).

Combined position and draft control

For this type of work:

- place the implement in the ground and set the desired depth following the instructions described under “draft control”;
- when the implement is at the desired depth, move the position control lever (24) backward until the arms of the lift tend to rise.

Note:

In this situation, the lift uses draft control. However, if the implement runs into less resistant soil, it prevents the implement from going too far into the ground.

- lower and raise the implement at the beginning and end of each pass using the position control lever (24).

Transfer on roads with an implement attached

When driving on roads with an implement attached to the tractor:

- Turn the lever (26) that adjusts the lowering speed of the arms completely counter-clockwise;
- Move the position control lever (24) completely backward.

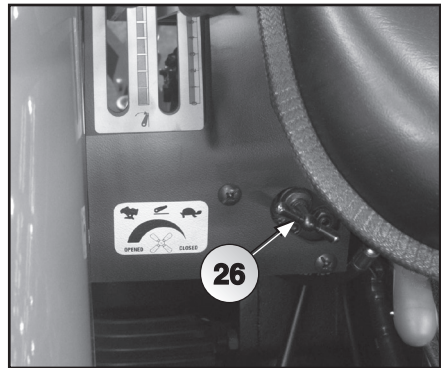

Fig. 5.59

18.4 Auxiliary hydraulic directional control valves

Note:

To ensure smooth operation of the hydraulic circuit, check the transmission oil level often and, if considerable oil is used for external circuits, increase the oil level as indicated in paragraph 6 -"Periodic Maintenance".

The auxiliary hydraulic spool valves (22-23) are used to operate single and double acting hydraulic cylinders connected into the tractor's hydraulic circuit with quick couples and suitable hoses with male "Push-Pull" 1/2" fittings.

⚠ Warning:

Make sure that the hydraulic cylinders of the implements that are connected contain the same type of oil as the tractor transmission to prevent its pollution and possible malfunctioning.

⚠ Warning:

Leaking pressurized hydraulic fluid can be powerful enough to penetrate the skin. The fluid for hydraulic controls can also cause cuts in the skin. If injuries occur due to leaking fluid, see a doctor immediately. Otherwise, serious infection and skin reactions are possible. The tightness of all of the connection devices and the conditions of the hoses and pipes must be checked before placing the system under pressure. Discharge the pressure fully before disconnecting hoses and before carrying out other types of work on the hydraulic system. Never check for leaks with hands; instead, use a piece of cardboard or wood.

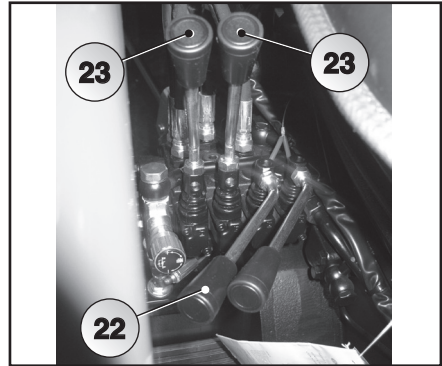

Fig. 5.60

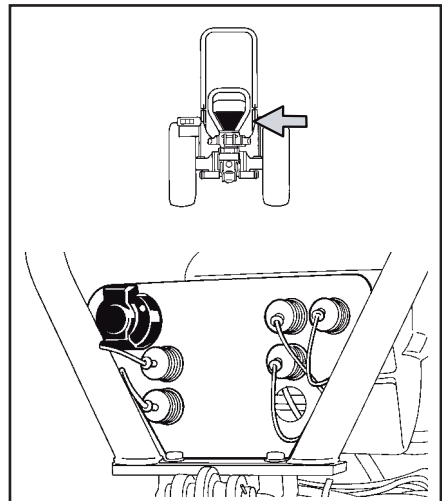

Fig. 5.61

To connect the hose to the tractor, proceed as follows:

- clean the implement male fitting;
- turn off the engine;
- make sure that the hydraulic lift is lowered;
- activate the directional control valve lever that will be used for the connection several times for its entire travel to discharge the pressure from the circuit;
- remove the protective cap of the quick hitch connected to the directional control valve;
- thoroughly clean the port and the coupling;
- act on the locking ring nut and push the coupling onto the port. Make sure that it is securely engaged by lightly pulling it backward.

After these operations have been carried out, the engine may be restarted and the directional control valve may be used.

To disconnect the hose from the tractor, proceed as follows:

- turn off the engine;
- activate the directional control valve lever that will be used for the connection several times for its entire travel to discharge the pressure from the circuit;
- act on the locking ring nut and forcibly pull the coupling to disconnect it from the rear port of the tractor;
- cover the port with the cap and clean it.

 **Warning:**

In order to guard the driver's safety when engaging the quick hitches it is necessary to keep at distance from the range of the implements. For greater safety it is advisable to use throttle valves acting on the hydraulic workings.

Section 19 : Removing the tyres

Warning:

All persons fitting and removing tyres must have received appropriate training and possess the necessary equipment.

To remove the tyre, proceed as follows:

1. Park the tractor on a firm, level surface.
2. Switch off the engine and remove the key.
3. Disconnect any connected equipment from the power takeoff.
4. Dismantle any ballast on the tyres.
5. Position a jack underneath the central gearboxes and raise the tractor.
6. Completely unscrew the nuts and remove the tyre.

Warning:

Pay attention when raising the tractor that the weight is evenly distributed and stop the axle swaying by placing suitable supports underneath the wheels.

Warning:

Tighten all the nuts and bolts to the correct driving torque value.

Tightening torques (Nm)

	A	B
M14	-	112±12
M16	-	270±27
M18	285÷300	-

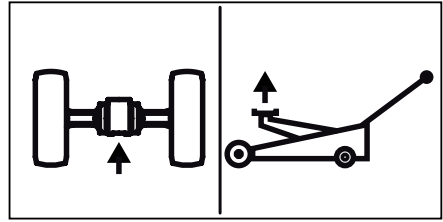

Fig. 5.62



Fig. 5.63

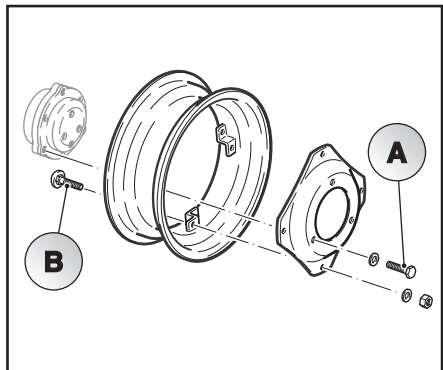

Fig. 5.64

19.1 Adjusting the wheel track

The tractor may be adjusted to carry out the work of the various implements and various crops, by changing the front and rear wheel track.

The tractor may be adjusted to carry out the work of the various implements and various crops, by changing the front and rear wheel track.

Note:

Always check the pressure of the tires.

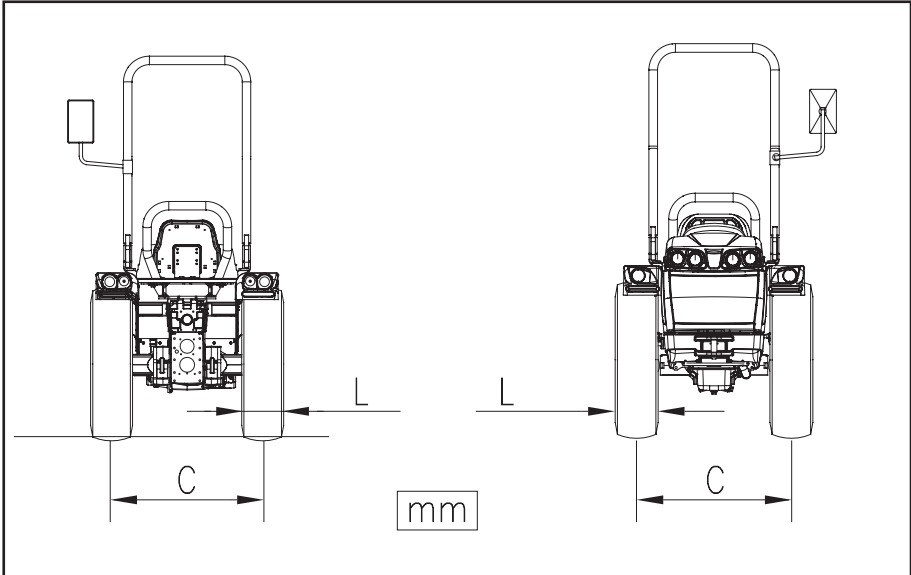
Wheel track (AR model tractor)

Fig. 5.65

Tire	L	C							
8.25-16	212	794	827	851	884	1010	1043	1067	1110
250/80-18	240	-	865	881	943	955	1017	1033	1107
280/70-18	282	-	869	877	931	967	1021	1029	1119
320/65-18	319	-	-	-	931	967	1021	1029	1119
260/70-20	258	-	846	902	936	966	1000	1056	1120
31x15.50-15 XTC	368	-	1003	-	-	-	-	-	-
31x15.50-15 STG	394	-	1003	-	-	-	-	-	-
31x13.50-15	351	-	991	-	-	-	-	-	-

USER REGULATIONS

Wheel track (RS model tractor)

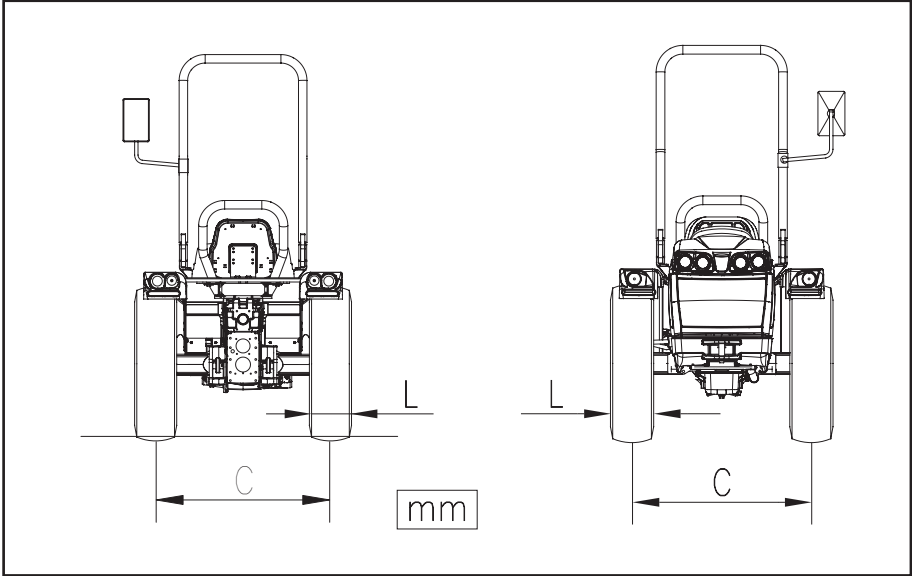

Fig. 5.66

Tire	L	C							
8.25-16	212	999	1032	1056	1089	1215	1248	1272	1305
250/80-18	240	996	1070	1086	1148	1160	1222	1238	1312
280/70-18	282	984	1074	1082	1136	1172	1226	1234	1324
320/65-18	319	-	1074	1082	1136	1172	1226	1234	1324
260/70-20	258	987	1051	1107	1141	1171	1205	1261	1325
31x15.50-15 XTC	368	1100	1208	-	-	-	-	-	-
31x15.50-15 STG	394	1100	1208	-	-	-	-	-	-
31x13.50-15	351	1112	1196	-	-	-	-	-	-

Section 20 : Transporting the tractor

The tractor must be transported with a suitable means of transportation.

Warning:

Avoid lifting the tractor with a crane or other unsuitable lifting devices.

Before transporting the tractor, the parking brake must always be engaged.

Warning:

Use suitable ramps for loading on to the transport vehicle.

Warning:

Do not hook or connect chains around the tractor parts, which could be damaged by the chains themselves or by excessive loads.

After the tractor has been loaded onto a suitable means of transportation, secure it with suitable anchoring belts or chains (143).

The trailer must always have the warning signs and lights that are required by law.

If the tractor is towed, the power steering system can be used to drive and turn for a short distance with the engine off.

Always operate the tractor from the operator position and:

- place the transmission levers in neutra;
- disengage the parking brake;
- place the PTO lever in neutral (27);
- always slow down and stop the tractor with the brake pedals coupled (RS model);

- use the rotating light and the flashing indicator lights.

Note:

When the engine is off, greater effort must be used for steering.

Note:

Always tow or push the tractor at a moderate speed.

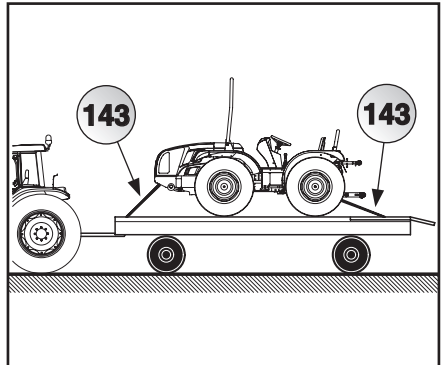

Fig. 5.67

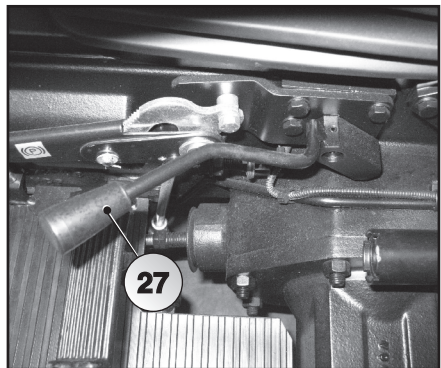

Fig. 5.68

Section 21 : Front ballasts

Front ballasting by means of specific cast iron plates is foreseen, in case heavyweight implements are attached to the tractor and they compromise its longitudinal stability. Maximum four plates, 20 kilos each, can be attached to the tractor.

⚠ Warning:

The total weight of the tractor, front ballasting and attached implements included, must not exceed the maximum load allowed on the axles.



Fig. 5.69

Chapter 6 : Periodic maintenance

Contents

Section 1 : Introduction and safety.....	136
Section 2 : Refueling the tractor.....	138
Section 3 : Accessibility for inspection and maintenance.....	139
Section 4 : Running-in period.....	140
Section 5 : Periodic maintenance summary table	142
Section 6 : Flexible periodic maintenance.....	142
Section 7 : Radiator	143
Section 8 : Air filter	144
Section 9 : Tractor parts lubrication.....	146
Section 10 : Front axle oil level	149
Section 11 : Reduction gears on front wheels oil level.....	149
Section 12 : Gearbox and rear axle oil level	150
Section 13 : Tires	150
Section 14 : Front axle oil change.....	151
Section 15 : Reduction gears of the front wheels oil change	152
Section 16 : Rear axle oil change	153
Section 17 : Air filter and hydraulic circuit filter change.....	154
Section 18 : Clutch.....	155
Section 19 : Service brakes	156
Section 20 : Extraordinary maintenance	157
Section 21 : Fuel circuit air bleeding	157
Section 22 : Alternator belt tension check.....	158
Section 23 : Electrical system - battery.....	158
Section 24 : Electrical system - alternator.....	160
Section 25 : Electrical system - fuses	161
Section 26 : Electrical outlet for trailer.....	163
Section 27 : Lights - bulb replacement.....	164
Section 28 : Extensive non-use of the tractor	165
Section 29 : Extraordinary maintenance	166
Section 30 : Troubleshooting.....	166

Section 1 : Introduction and safety

The maintenance procedures for keeping your tractor running well are indicated in this section. The table in the next section can be used as a quick reference for maintenance. Each operation indicated in the table is numbered and described in detail in later paragraphs. The intervals suggested in the table refer to “normal operating conditions” of the tractor. Under adverse operating conditions such as humidity, mud, sand and high dust levels, the intervals should be shortened.

Note:
The operations described in this section ensure proper operation of the tractor when carried out at the prescribed times.

Note:
For engine maintenance, refer to the relative user and maintenance manual supplied with the tractor.

Before proceeding with tractor maintenance, read and follow all of the safety precautions indicated in section 2 in the paragraph entitled “Tractor maintenance”.

Warning:
Do not carry out checks, maintenance or adjustments on the tractor while the engine is running. All operations must be carried out with the engine off.

Warning:
Park the tractor on a level surface and, if possible, lengthen all of the cylinders before checking the oil levels.

Note:
Dispose of used filters and liquids appropriately, in complete observance of current laws.



Fig. 6.1

To prevent contamination when changing filters, oil, etc., always clean the areas surrounding the filler plugs, level plugs, drain plugs, dipsticks and filters.

Note:

The tractor instrument panel has lights that indicate the condition of your vehicle. Some of these indicate anomalies. Intervene promptly when these come on (see Section 4 - Instruments and controls).

**Warning:**

No special equipment is required.

The following components should be checked periodically. In the event of anomalies, contact your area dealer for repair:

- Hydraulic hoses. The hoses must not be flattened or have cracks or bulges in the external sheath and must not leak oil between the hose and the fitting;
- Nut tightness;
- Tightness of screws that secure the rollbar;
- Tightness of nuts and bolts in general.

Section 2 : Refueling the tractor

Warning:

Do not smoke near diesel. Never add gasoline, alcohol, or a mixture of diesel or alcohol to diesel because the risk of fire and explosion increases considerably. In a closed container like a jerry can, they are more explosive than pure gasoline.

Warning:

Do not use these mixtures. Furthermore, diesel and alcohol mixtures are not approved due to insufficient lubrication of the fuel injection system.

Warning:

Clean the area of the filler plug and keep it clean.
Fill the tank at the end of the day to limit nighttime condensation.

Warning:

Never remove the plug or refuel while the engine is running. Keep the fuel nozzle under control while filling the tank.

Warning:

Do not fill the tank completely. Leave space for increasing volume. If the original tank plug is lost, replace it with an original spare part and tighten completely.

Fuel requirements

Fuel quality is an important factor regarding engine performance and reasonable lifetime. The fuels must be clean, well-refined and not corrosive to parts of the fuel system. Be sure to use fuel with a known quality from a reliable source.

Refueling

Before filling the tank, clean the area around the filler plug to prevent foreign bodies from entering the tank. When fueling is finished, screw the plug on again and tighten well.

Note:

The fuel tank capacity is 45 liters.



Fig. 6.2

Section 3 : Accessibility for inspection and maintenance

⚠ Warning:

Before opening the bonnet, always stop the engine, remove the ignition key and engage the parking brake.

⚠ Warning:

Touching hot surfaces causes burns. After running, the engine and its components and fluids may be hot. Let the engine cool down before carrying out servicing to the tractor or working near it.

To access the engine parts and carry out inspections and maintenance of the engine itself and all of the assembled parts, the tractor hood must be opened.

The engine hood may be easily raised using the provided lever (154) located on the left just under the side guard panel.

⚠ Warning:

Do not use the tractor without the hood or sides.

Note:

If the hood cannot be raised using the lever (154), use a screwdriver (155) to manually release the hood coupling pin.

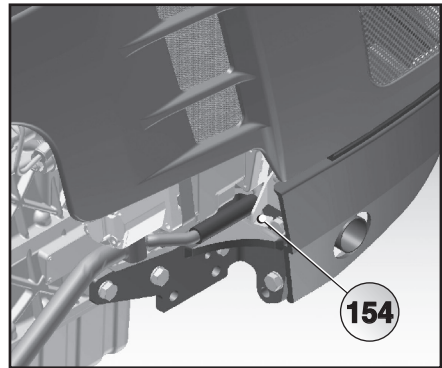

Fig. 6.3

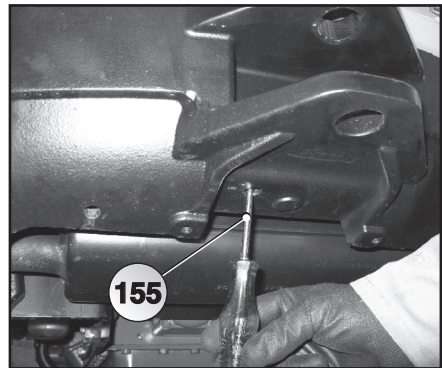

Fig. 6.4

Section 4 : Running-in period

For the first 50 hours of operation of the engine, it is recommended not to exceed 75% of the maximum output power.

After the first 50 hours of operation

- Replace the filtering elements (153).
- Check the oil level of the rear transmission unit (Fig.6.6), as described in the periodic maintenance instructions.
- Check the tightness of all of the bolts, screws and nuts.
- Lubricate all of the points with lubricators.
- Replace the oil in the engine pan (150) and the relative filter cartridge (151). Then replace the engine oil and the engine oil filter at the times specified in the periodic maintenance section. Follow the instructions in the engine's user and maintenance manual.

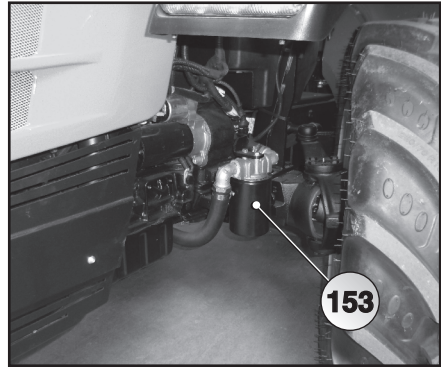

Fig. 6.5

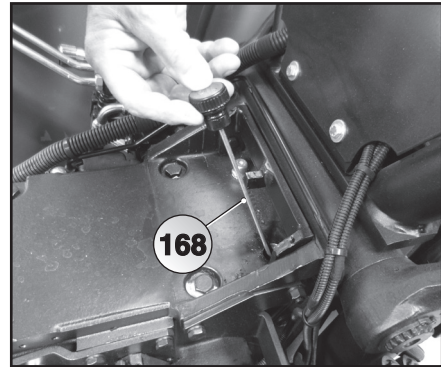

Fig. 6.6

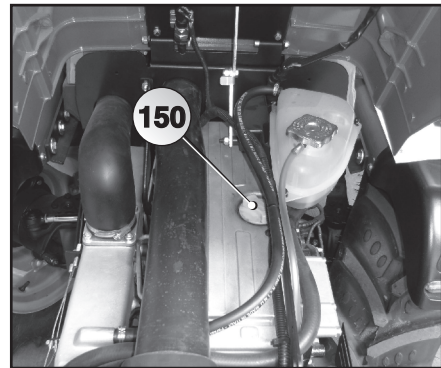

Fig. 6.7

- Verify the travel of the brake pedals.
- Check the pressure of the tires.
- Check the V-belt, following the instructions in the relative user and maintenance manual of the engine.

Note:

If using hydraulically-controlled implements, which take oil from the tractor, it is necessary to keep the oil level in the gearbox under control.

⚠ Warning:

The levels must be checked and topped up with the tractor parked on a flat surface and with the engine stopped for at least 10 minutes.

⚠ Warning:

Use oil with the same characteristics as those indicated in the “Fuel and lubricants table”. Do not dispose of polluting material in the environment. Dispose of oils in compliance with the pertinent laws in force.

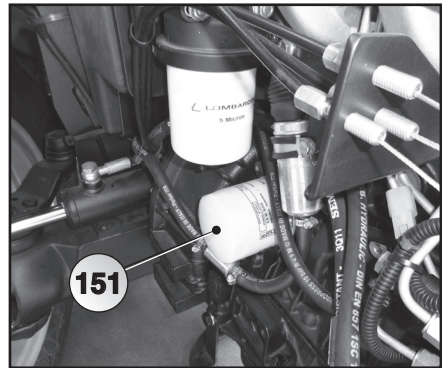
**Fig. 6.8**

Section 5 : Periodic maintenance summary table

The maintenance and inspection periodic operations are listed in the “Routine maintenance” chapter of service manual, supplied together with the tractor.

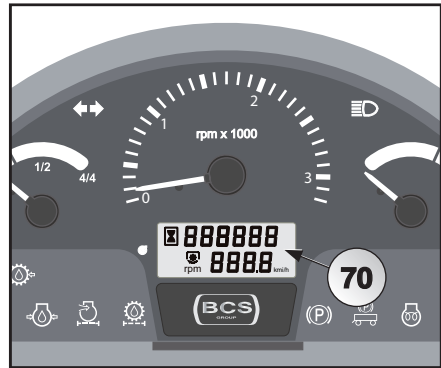

Fig. 6.9

Section 6 : Flexible periodic maintenance

The maintenance operations that must be carried out at the specified times to keep the tractor running well are described in the following paragraphs.

The hours of tractor operation are indicated by the counter on the instrument panel (70).

Before proceeding with lubrication of the parts with lubricators, clean their surfaces thoroughly and make sure that the ball bearing is free. After lubrication has been carried out, remove all grease residues to prevent the accumulation of soil and dust.

Section 7 : Radiator

For proper operation of the cooling circuit, it is important that the radiator fins (156) and the front grille (159) of the engine hood are clean.

Note:

If the work environment is particularly dusty, it should be cleaned often, even several times a day.

Check the radiant surface often for obstructions, based on the conditions of tractor use. Monitor the engine cooling water temperature indicator (86) on the instrument panel.

Warning:

The engine cooling system build up pressure as the engine gets hot. Before removing the radiator cap, shut off the engine and wait for the system to cool down.

Warning:

The radiators and grilles must be cleaned while the engine is cold; when overheated, they can burn fingers and hands.

Clean the radiator (156) with compressed air directed from the inside to the outside.

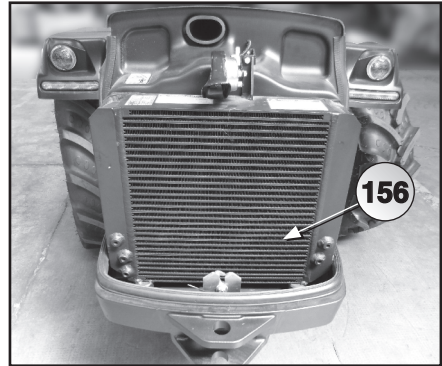

Fig. 6.10



Fig. 6.11

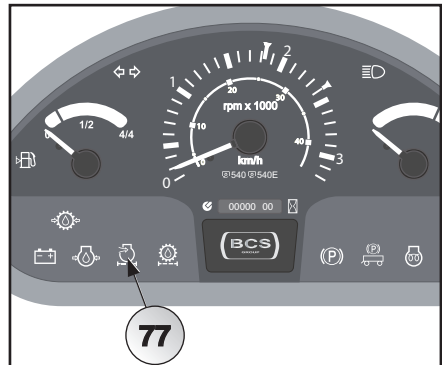

Fig. 6.12

Section 8 : Air filter

If working in particularly dusty environments, the air filter should be cleaned often. This operation should be carried out every 8-60 hours; follow the instructions in the engine's maintenance booklet.

Warning:

The filtering elements must always be cleaned while the engine is off.

If the light (77) on the instrument panel comes on, the engine air filter is clogged. In this case, the filtering elements must be cleaned.

Warning:

Never use oil, petroleum, diesel oil, paraffin or other solvents to clean the filter. Compressed air should be used.

Per accedere al filtro (161) è necessario:

- remove the guard panel (160);
- open the filter cover (162) by unscrewing the knob (163);
- loosen the nut (164) that secures the filter container to facilitate removal;
- unscrew the knob (165) that holds the filter in place and remove the external cartridge (161) from the housing.

Clean the filtering element with compressed air or water, dry and reassemble. Always make sure that the filter housing is not damaged and that all of the pipes and fittings are tightened.

The external cartridge (161) may be cleaned or washed a maximum of six times.

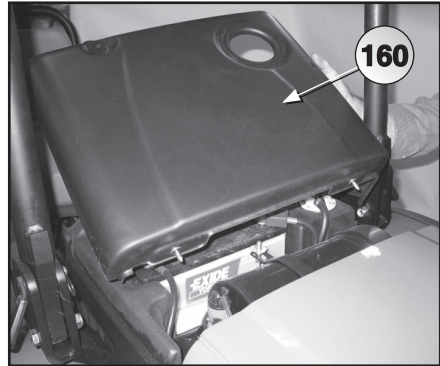

Fig. 6.13

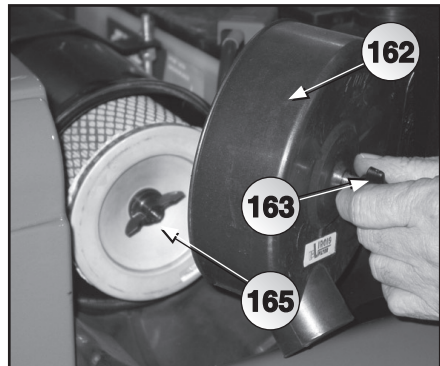

Fig. 6.14

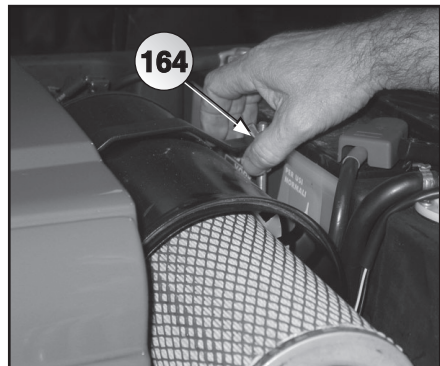

Fig. 6.15

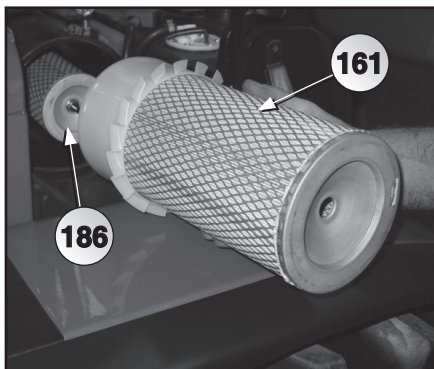

Fig. 6.16

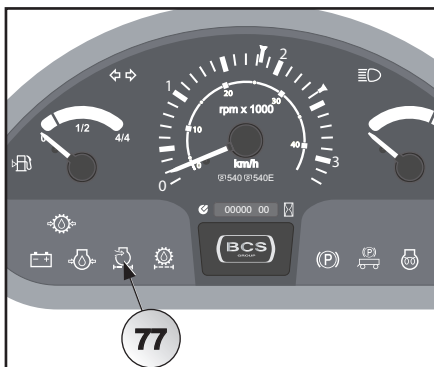

Fig. 6.17

Section 9 : Tractor parts lubrication

Lubricate the various tractor parts every 50 hours, or more often depending on the environmental conditions, at the lubrication points indicated below.

Note:

After lubrication, carry out a general check of the tractor to verify that there are no oil leaks, loose parts or damage.

Before proceeding with lubrication of these parts, clean their surfaces thoroughly and make sure that the ball bearings are free.

After lubrication has been carried out, remove all grease residues to prevent the accumulation of soil and dust.

Use AGIP GREASE SM 15 for lubrication.

Ref.	Parts that must be lubricated	AR/Q.ty	RS/Q.ty
A	Steering joint	2	4
B	Front axle oscillation	2	2
C	Three-point hitch lift	1	1
D	Steering jack pins	-	2

Lubrication points (AR model)

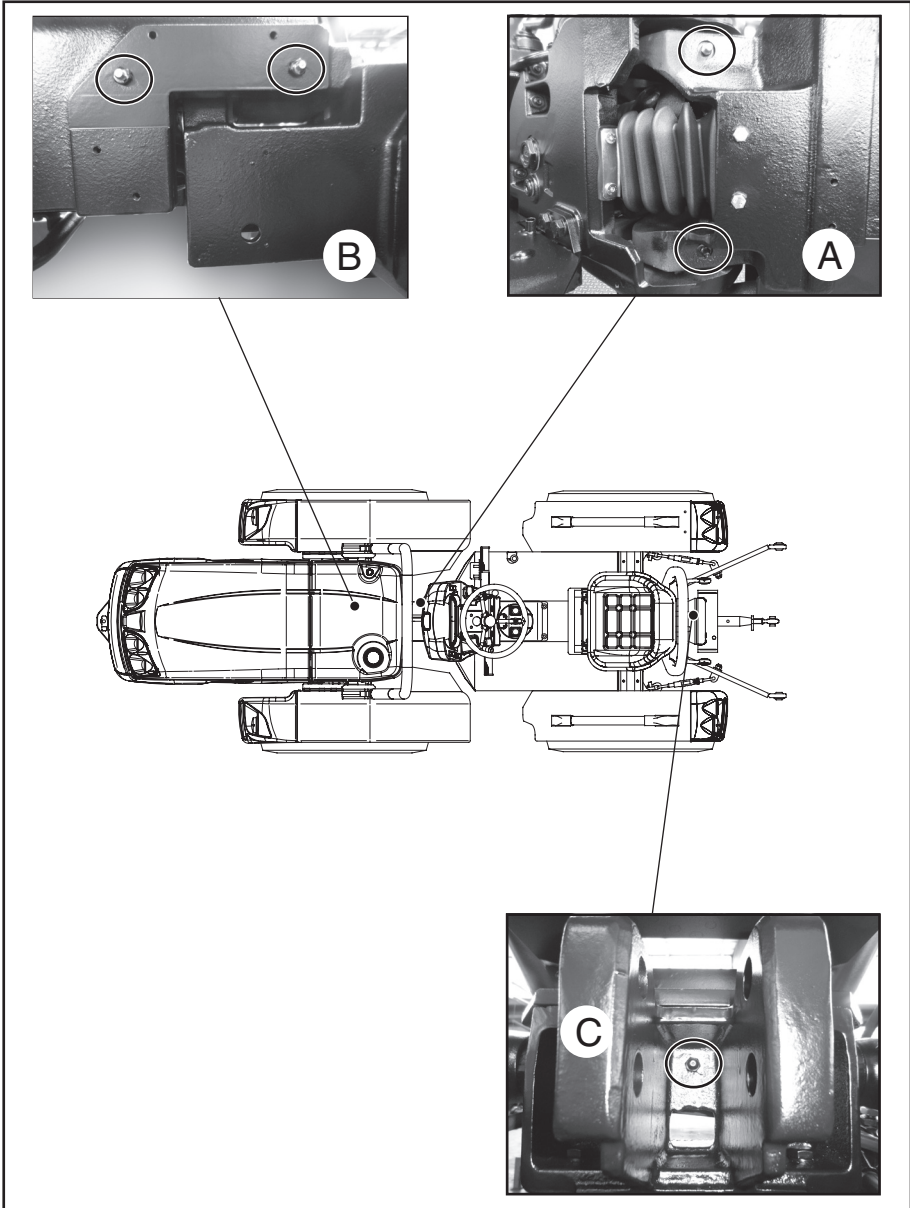

Fig. 6.18

Lubrication points (RS model)

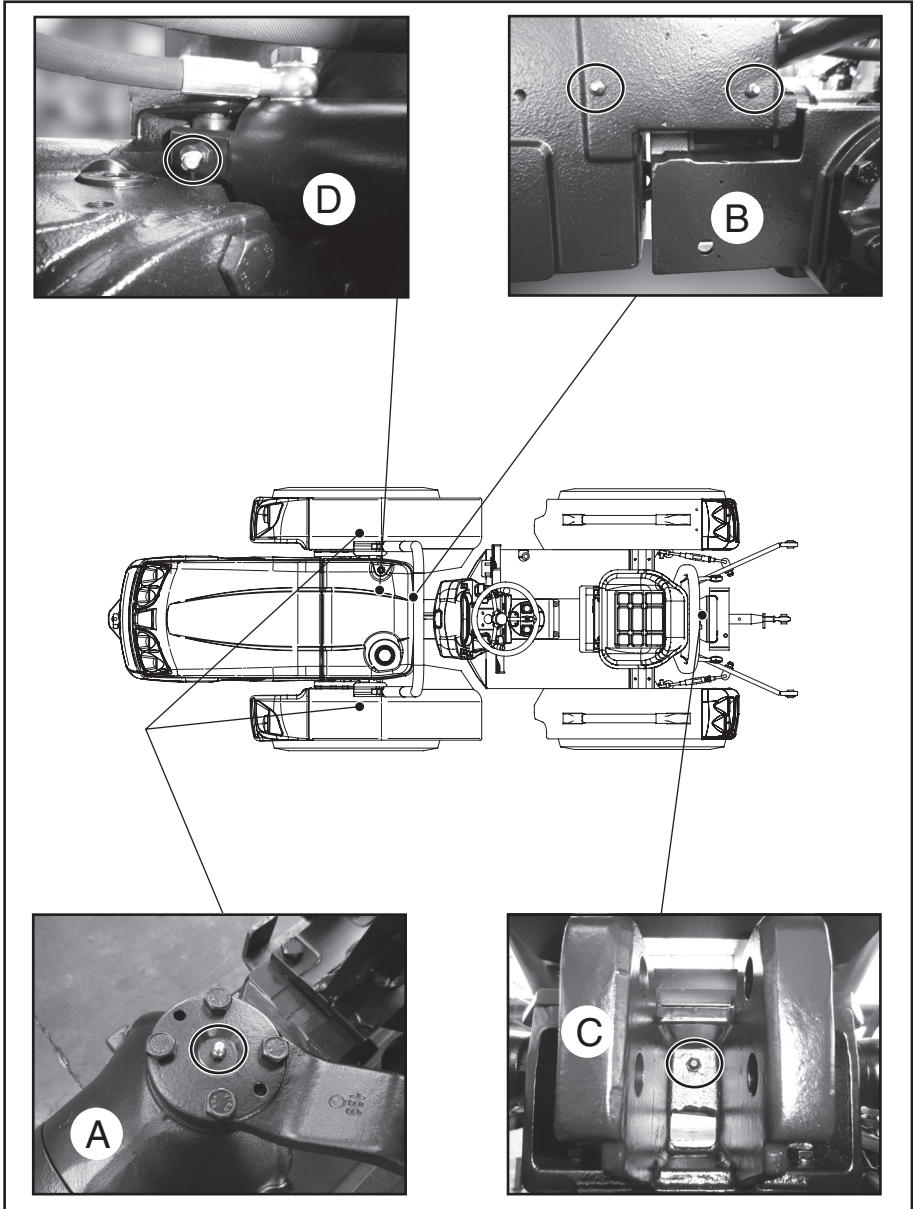

Fig. 6.19

Section 10 : Front axle oil level

Regularly check the oil level in the front axle.

Note:

Before checking the oil level, let the oil settle in the transmission.

To check the level:

- remove the plug (166);
- verify that the oil is close to the edge of the hole;
- if not, top off with **BCS POWERLUBE W13T** oil;
- replace the plug (166).

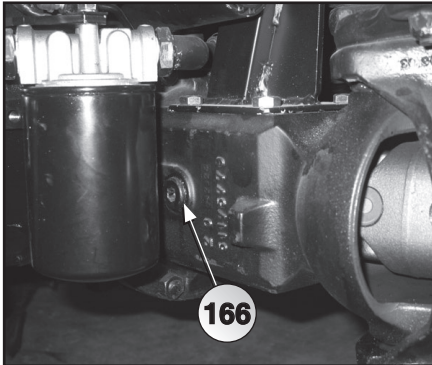

Fig. 6.20

Section 11 : Reduction gears on front wheels oil level

Regularly check the oil level in the front reduction gears.

Note:

Before checking the oil level, let the oil settle in the transmission.

To check the level:

- position the tractor so that the plug (1) is located on the horizontal center line of the tractor itself;
- remove the plug (167);
- verify that the oil is close to the edge of the hole;
- if not, top off with **BCS POWERLUBE W13T** oil;
- replace the plug (167).

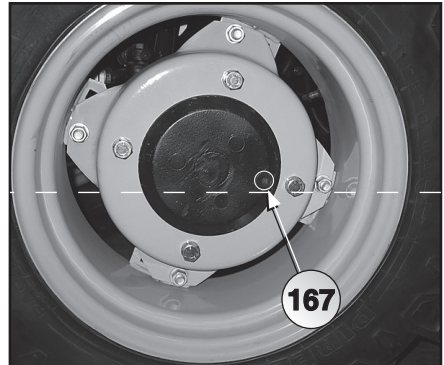

Fig. 6.21

Section 12 : Gearbox and rear axle oil level

Check the oil level in the transmission units on a regular basis.

Note:

Before checking the oil level, let the oil settle in the transmission and make sure that the hydraulic lift arms are completely lowered.

To check the level:

- lift completely the seat;
- remove the gearstick dipstick (168);
- check that the oil level is between the maximum and minimum notches on the dipstick (168);
- if this is not the case, top off with **BCS POWERLUBE W13T oil**;
- replace the dipstick (168) in the gearbox case.

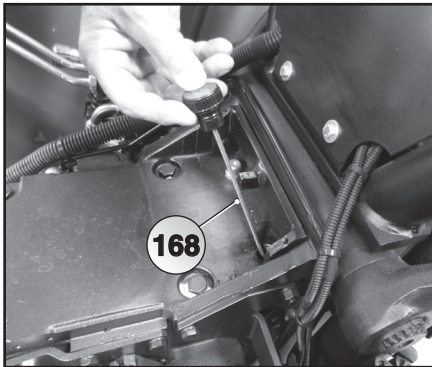

Fig. 6.22

Section 13 : Tires

The tire pressure must be the same on all four tires. Therefore, periodically verify the correct inflation pressure.

The correct pressures are indicated in the table on the left.

The first value indicates the minimum pressure. The second value indicates the recommended pressure for driving on roads.

Note:

The values in the table refer to the weight of the tractor only. The inflation pressure of the tires should be increased depending on the type of implement attached.

Tires	Pressure	
	bar	psi
8.25-16	1,3 - 2	18.8 - 29
250/80-18	2 - 2,8	29 - 33
280/70-18	0.6 - 1.6	8.7 - 23.2
320/65-18	0.6 - 1,8	8.7 - 26.1
260/70-20	1 - 2,4	14.5 - 34.8
31x15.50-15 XTC o STG	0.8 - 1.4	11.6 - 20.3
31x13.50-15	0.8 - 1.4	11.6 - 20.3

Section 14 : Front axle oil change

To change:

- remove the plug (166);
- position a container under the drain plug (169) underneath the axle case;
- remove the drain plug (169) and let all of the oil in the axle drain out;
- then reinsert the drain plug (169);
- replenish the case with 6.5 lt (AR model) / 5 lt (RS model) of **BCS POWER-LUBE W13T** up to the edge of the plug (166);
- then replace the plug (166).

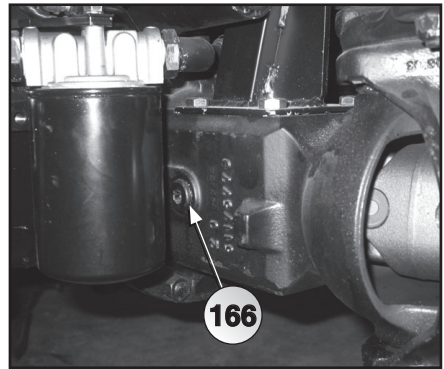

Fig. 6.23

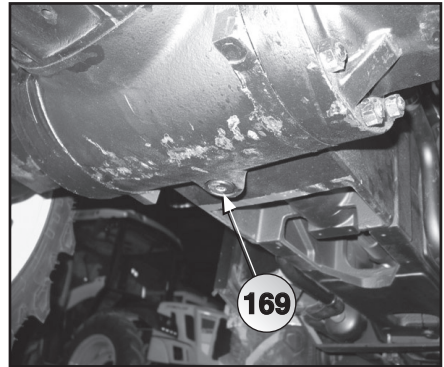

Fig. 6.24

Section 15 : Reduction gears of the front wheels oil change

To change:

- position the tractor so that the plug (167) is at the lowest point of the tractor itself;
- remove the plug (167) and let all of the oil in the reduction gear drain out;
- position the tractor so that the plug is on the horizontal center line of the tractor itself;
- replenish the case with **BCS POWER-LUBE W13T** (0.75 lt RS tractor) up to the edge of the plug (167);
- then replace the plug (167).

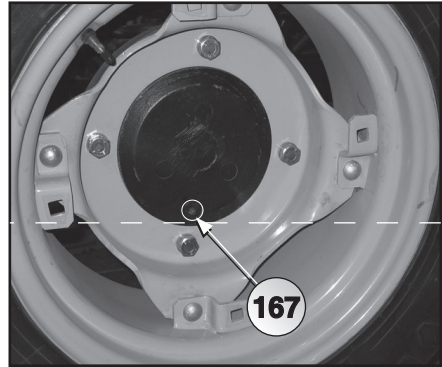

Fig. 6.25

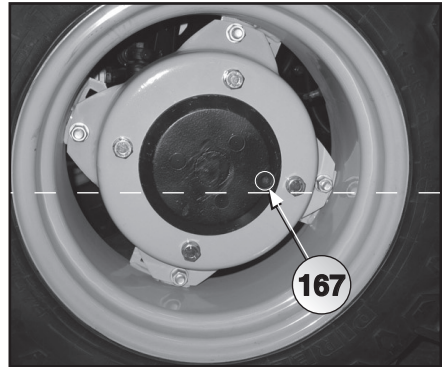

Fig. 6.26

Section 16 : Rear axle oil change

Note:

Before changing the oil, let it settle in the transmission and make sure that the hydraulic lift arms are completely lowered.

To replace:

- lift completely the seat;
- remove the gearbox dipstick (168);
- position a container under the drain plug (170) underneath the gearbox case;
- remove the drain plug (170) and let all of the oil in the gearbox drain out;
- then reinsert the drain plug (170) and the relative gasket;
- replenish the case with 14.5 lt (AR model) / 16 lt (RS model) of **BCS POWERLUBE W13T** oil through the filler hole;
- reinsert the dipstick (168) into the gearbox case;
- start the engine and operate the hydraulic lift for a few cycles and then leave it in the lowest position;
- recheck the oil level in the case using the dipstick (168). If necessary, top off to the maximum level.

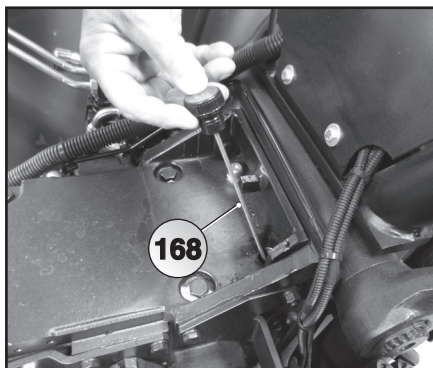

Fig. 6.27

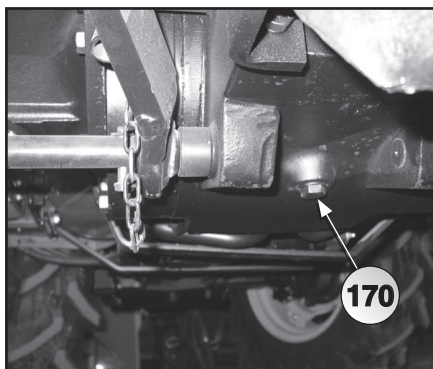

Fig. 6.28

Section 17 : Air filter and hydraulic circuit filters change

The filter elements (161) (186) (153) should be replaced according to what it is described; it needs also check their efficiency whenever the warning light placed in the instrument panel (75-77 Fig.4.10) is on.

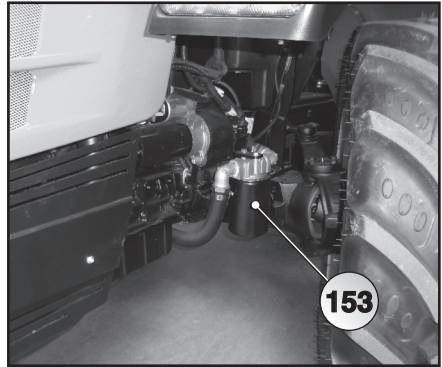

Fig. 6.29

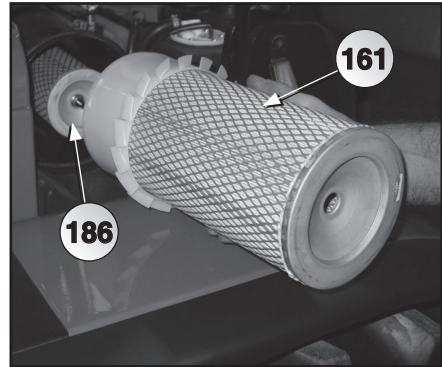

Fig. 6.30

Sezione 18 : Clutch

On a periodic basis, check that the empty stroke of the clutch pedal (1) is approximately 5-10 mm.

If it becomes necessary to adjust it, proceed as follows:

- tighten the nut (a) in order to restore the empty stroke;
- tighten the lock nut (b);
- if the clutch pedal stroke is excessive, it is necessary to adjust the same nut in the opposite direction, first unscrewing the lock nut (b).



Fig. 6.31

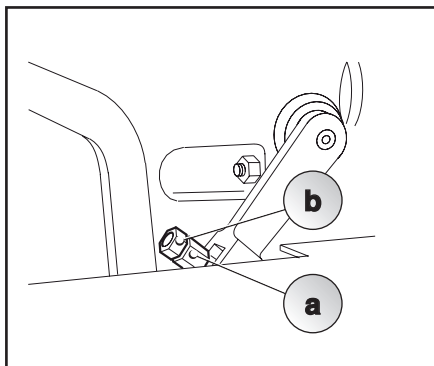

Fig. 6.32

Sezione 19 : Service brakes

⚠ Warning:

When the brakes feel loose, identify the cause and eliminate the defect immediately.

Periodically check that the brake pedals have a slight empty stroke of approximately 20 mm.

The adjustment described below must be carried out on both tie rods of the service brakes.

- If the empty stroke of the pedals (or pedal in the AR model) is excessive, adjust the tie rods (6) using the nut (a).
- Once adjustment is complete, tighten the lock nut (b).

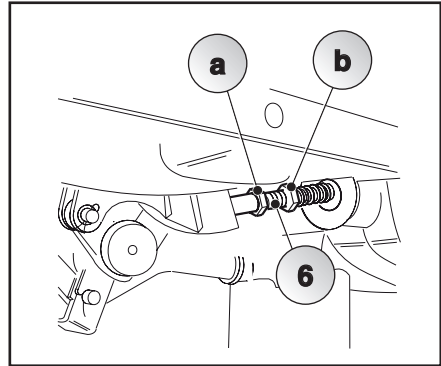

Fig. 6.33

Section 20 : Extraordinary maintenance

If detailed inspection and maintenance operations become necessary such as tuning, adjustment, repair and replacement of components, contact qualified personnel. Contact your area dealer for these operations.

Section 21 : Fuel circuit air bleeding

The presence of air in the pipes of the fuel circuit makes engine starting difficult. Air can enter the circuit when the filters and pipes are disassembled, during long periods of inactivity and when the fuel in the tank is depleted.

This operation should be carried out by qualified personnel; contact your area dealer.

Note:

Always try to keep fuel in the tank to prevent air from entering the relative engine ignition circuit.
--

Section 22 : Alternator belt tension check

Refer to the chapter “Alternator belt tension control” in the “KOHLER Diesel KDI” use and maintenance manual, supplied with the tractor.

Note:

If the belt has cracks or needs to be adjusted often, have it replaced at an authorized service center.

Section 23 : Electrical system - battery

The battery (179) is located in the front. To access it, remove the guard panel (160).

The battery is maintenance free and therefore does not need to be topped off with distilled water. The top of the battery must be kept dry and clean. Periodically check that the fluid level never goes below the minimum mark.

If it must be replenished:

Warning:

Before recharging the battery, remember to disconnect the cables. It should be removed from its housing and should be recharged away from the tractor.

Warning:

During battery recharging, ventilate the room and do not approach it with sparks or lit cigarettes.

- remove the caps of the elements;
- add only distilled water to the specified level, being careful not to exceed the maximum line.

Warning:

Never top off the battery with sulfuric acid.

Warning:

The poles and terminals of the batteries and the relative accessories contain lead and lead compounds, chemical substances. Wash your hands every time they come into contact with these parts.

⚠ Warning:

When replacing the battery, disconnect the negative terminal first, then the positive terminal.

When fitting the battery back, connect the positive terminal first, then the negative terminal.

⚠ Warning:

Do not connect any other accessory to the battery.

Note:

In the case of frequent topping off or if the battery tends to run down, have the electrical system of your tractor checked by specialized personnel from your area dealer.

Note:

The batteries and the electric accumulators contain various components that can be harmful to the environment if they are not correctly recycled after use.

It is strongly recommended that all “dry” batteries that can be used in electric or electronic systems are returned to your dealer, which will guarantee proper disposal or recycling. In some countries this is required by law.

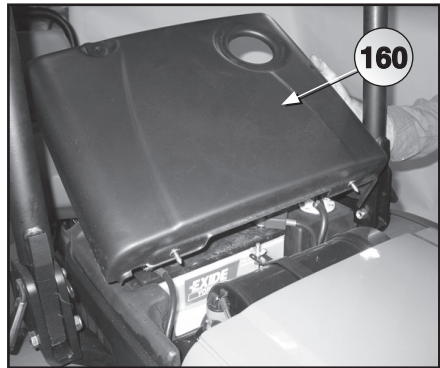

Fig. 6.34

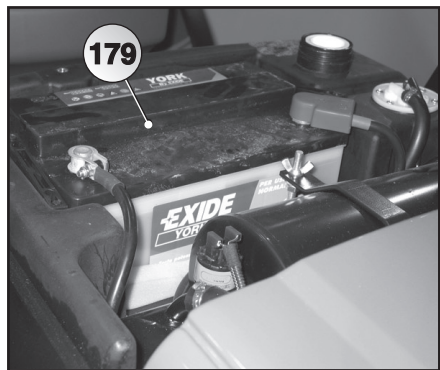

Fig. 6.35

Section 24 : Electrical system - alternator

The alternator (181) always ensures maximum battery charge.

It does not require special maintenance since it does not have brushes, but does require a few special precautions..

- 1 - When the battery is installed, make sure that the ground poles of the battery and the alternator have the same mark. If the battery poles are inverted, it will short-circuit through diodes.
- 2 - When charging the battery, make sure that the poles correspond exactly, the positive pole of the charger with the positive pole of the battery (+) and the negative pole of the charger with the negative pole of the battery (-), to prevent damaging the diodes and the system.
- 3 - Never operate the alternator with the system disconnected.
If the battery is disconnected, the voltage could become too high and dangerous if someone touches the alternator output pole.
Before checking and testing the tractor, make sure that the connections are secured.
- 4 - Never short-circuit or ground one of the alternator poles since this would damage the electrical system.
- 5 - Do not invert the alternator polarity. It is extremely important that the battery ground and the alternator ground have the same polarity so that the diodes are not damaged.
- 6 - Never arc weld without first disconnecting the alternator cables.

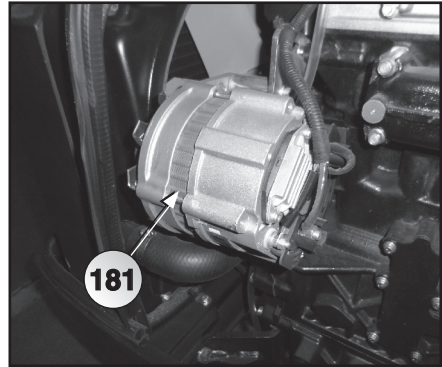

Fig. 6.36

Section 25 : Electrical system - fuses

The tractor electrical system is protected against short circuits and excessive current absorption by fuses.

The main fuses (183) are positioned on the rear side of the dashboard. To access them, remove the guard panel.

Note:

Before replacing a fuse with a similar one, the causes that created the problem should be identified and repaired.

⚠ Caution:

If fuses must be replaced, only use ones with the same characteristics as those indicated in the following table.



Fig. 6.37

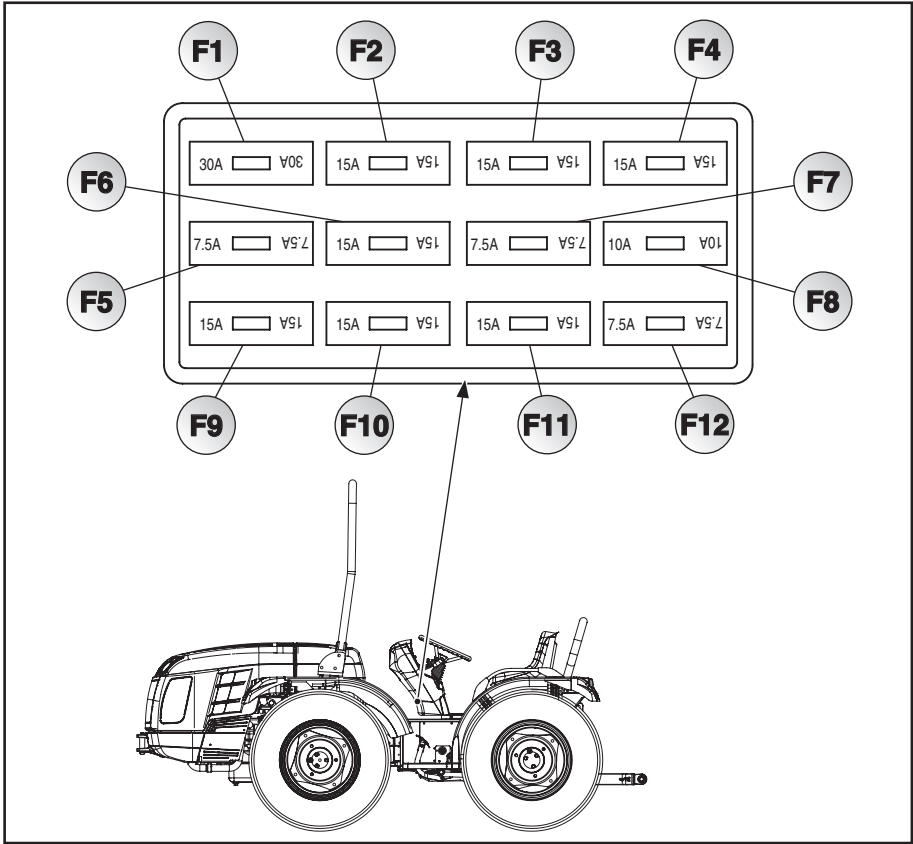

Fig. 6.38

F1	30	General fuse
F2	15 A	Full beam headlights
F3	15 A	Dipped headlights
F4	15 A	Front right and rear left position lights, rear work light, license plate light
F5	7.5 A	Left front and right rear position lights
F6	15 A	Horn
F7	7.5 A	Turn signals
F8	10 A	Differential lock and PTO solenoid valves, PTO engagement relay
F9	15 A	Brake lights
F10	15 A	Emergency lights and instrument panel power (+15)
F11	15 A	Auxiliary electrical outlet and instrument panel power (+30)
F12	7.5 A	Engine stopping, start advance

Section 26 : Electrical outlet for trailer

On the rear of the tractor there is a 7-pin electrical outlet (28) for connecting the electrical system of the trailer (lights system).

 Warning:

Remove the ignition key before making the electrical connections.

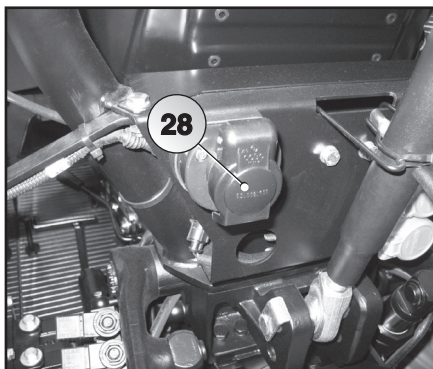

Fig. 6.39

Section 27 : Lights - bulb replacement

To replace the bulbs:

- open the engine hood;
- loosen the airtight guards that lock the bulb into place;
- disconnect the bulb connectors and remove the bulb itself.

Front lights:

Position lights	5W
Turn indicators	3W
Dipped beams	55W
Headlight main beams	55W

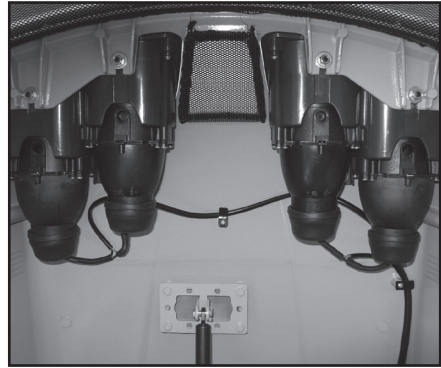

Fig. 6.40

Tail lights:

Position lights	5W
Turn indicators	3W
Brake lights	21W
Licence plate light	5W
Field light	55W

Section 28 : Extensive non-use of the tractor

When your tractor must remain unused for longer than one month, take the following precautions:

- place the tractor in a dry protected environment;
- protect the engine by observing the directions in the relative instruction booklet;
- drain the water from the radiator and the engine;
- lubricate all of the parts with lubricators;
- clean the fuel filter;
- remove the injectors, place a little engine oil in the cylinders, rotate the engine by hand, and then reassemble them;
- carry out general cleaning of the tractor and especially the body components. Protect painted parts by applying silicone wax and lubricate the unpainted metal parts. Place the tractor in a covered dry and, if possible, ventilated room;
- make sure that all of the controls are in neutral (including the electrical switches);
- do not leave the ignition key in the switch;
- make sure that the shafts of the cylinders (power steering, lift, etc.) are in the inclined position;
- empty the diesel tank and fill it with new diesel up to the maximum level;
- remove the battery, wipe off the lid and cover the terminals with Vaseline. Then place the battery in a ventilated room where the temperature does not go below 10°C, protecting it from the sun;
- check the charge using a voltmeter and, if necessary, recharge it;
- arrange stands or other supports under the axles to keep the wheels suspended. With the tractor raised, the

tires should be deflated. Otherwise, periodically check the tire pressure;

- perform general lubrication;
- cover the tractor with a cloth, avoiding waterproof material (oilcloth or plastic) because it tends to retain humidity, encouraging the formation of rust.

When non-use is finished, follow the operations below:

- remove the protective cloth;
- if the tractor was raised onto stands, inflate the tires to the specified pressure and then lower it to the ground;
- restore the engine to use by observing the directions in the relative user and maintenance manual;
- recharge the battery and reinstall it on the tractor.

Note:

When your tractor must remain unused for longer than one month, take the precautions at section 5: User regulations.

Section 29: Extraordinary maintenance

Only qualified personnel should carry out detailed inspection and maintenance work, for example registration, adjustment, repairs and replacement of components. Contact your nearest dealership for information.

Section 30 : Troubleshooting

The following information will help you to identify and correct some of the more common faults and malfunctions.

Engine

The information relating to possible troubles that may be encountered when using the engine are listed in the chapter "Troubleshoot useful information" of the "KOHLER Diesel KDI" use and maintenance manual, supplied with the tractor.

Electrical system

<i>Fault</i>	<i>Cause</i>	<i>Remedy</i>
No current in the electrical circuit	Main fuse damaged	Replace the fuse
	Discharged battery	Recharge or replace the battery
	Tarnished battery terminals	Clean the terminals and smear Vaseline grease over them
	Battery disconnecter in the "off" position	Turn the switch "on"
The battery fails to recharge (red alternator indicator light on with the engine running)	Worn or loosened alternator belt	Check the belt stretcher. Replace the belt if worn
	Faulty alternator	Contact your area dealer
	Faulty electrical system	Contact your area dealer
	Faulty battery	Replace the battery

Call your area dealer if you are unable to find the cause of a fault.

Hydraulic circuit

<i>Fault</i>	<i>Cause</i>	<i>Remedy</i>
The hydraulic circuit fails to function correctly	Oil level low	Top up the circuit
	Oil filter element clogged	Replace the filter
	Faulty hydraulic circuit	Contact your area dealer
The hydraulic oil overheats	Oil level too high or low	Top up the oil level
	Oil filter element clogged	Replace the filter
	Faulty hydraulic control valves	Contact your area dealer

Call your area dealer if you are unable to find the cause of a fault.

Hydraulic power lift

<i>Fault</i>	<i>Cause</i>	<i>Remedy</i>
The implement fails to lift	The implement is heavier than the maximum capacity of the power lift	Unhitch the implement. Before hitching another implement, make sure that its characteristics are compatible with those of the tractor.
	Transmission oil level low	Top up the oil level
	Oil pressure too low	Contact your area dealer
	Hydraulic pump damaged	Contact your area dealer
The implement lowers too fast	The lowering governor valve is not closed to a sufficient extent	Adjust the valve with the knob to obtain the best speed
The implement lowers too slowly	The lowering governor valve is not open to a sufficient extent	Adjust the valve with the knob to obtain the best speed

Call your area dealer if you are unable to find the cause of a fault.

Clutch

<i>Fault</i>	<i>Cause</i>	<i>Remedy</i>
The clutch fails to release correctly (the gears are difficult to engage)	Clutch incorrectly regulated	Use the adjuster nut
	The clutch is worn	Contact your area dealer

Call your area dealer if you are unable to find the cause of a fault.

Brakes

<i>Fault</i>	<i>Cause</i>	<i>Remedy</i>
The tractor fails to brake correctly	Brakes incorrectly regulated	Contact your area dealer
	Worn brake lining	Contact your area dealer
The hand brake fails to brake correctly	Hand brake incorrectly regulated	Contact your area dealer

Call your area dealer if you are unable to find the cause of a fault.

Wheels and steering system

<i>Fault</i>	<i>Cause</i>	<i>Remedy</i>
Tyres worn unevenly	Tyre pressure too low	Inflate the tyres to the correct pressure
Steering wheel excessively stiff to turn	Oil pressure too low	Contact your area dealer
The tractor fails to maintain the direction of the steering wheel	Air in the hydraulic circuit	Contact your area dealer
	Hydraulic cylinder seals worn	Contact your area dealer
The tractor fails to turn	Oil pressure too low	Contact your area dealer
	Hydraulic pump damaged	Contact your area dealer
	Defective power steering system	Contact your area dealer

Call your area dealer if you are unable to find the cause of a fault.



BCS S.p.A

Viale Mazzini, 161
20081 Abbiategrasso (Milano)
info@bcs-ferrari.it

www.bcsagri.it

