

REMOTE CONTROLLED HIGH GRASS FLAIL MOWER



Operating manual

MODEL:

XFLAIL



BHV
Barbieri Hybrid Vehicle

A - INTRODUCTION**INTRODUCTION**

This manual must be considered as a part of the machine. In the sales document the vendor of new and used machines must indicate that ... that his manual is to be handed over jointly with the machine.

PICTURES AND SYMBOLS USED IN THIS OPERATING MANUAL

Please read this operating manual thoroughly before commissioning this device and observe the following symbols and safety rules.

DANGER By this symbol important safety information is highlighted. Non-observance of this information leads to a major hazard of severe injury or death. This description also includes the common precautionary measures for the prevention of danger. Non-observance of these precautionary measures may lead to severe damage to the machine.



WARNING This warning in the safety instructions of the manual is used when there is a hazardous situation that may result in minor or moderate injury. The indications may also be used for hazards resulting in damages to the machine or its components.



IMPORTANT Precautionary measures are taken to prevent operations that may shorten the service life of the machine or its components.



NOTICE This word is used to highlight information that refers to current operations.

Each time these symbols are shown on the machine or in the following instruction, you must be aware that there is no danger for you nor for any other persons.

Follow some rules that are of the common sense. This way you will prevent the risk of defects while your machine will work longer and more efficiently.

B - TERMS AND CONDITIONS AND PROPER USE**DEFINITION OF INTENDED USE**

- This machine has been designed for brushcutting in public green areas as well as on plains and steep slopes.
- For the correct use, the essential elements such as usage conditions, maintenance and repair must be observed.
- The machine may only be used, maintained and repaired by staff familiar with the safety rules.
- The general rules for accident prevention and traffic rules on public roads must be observed.

MISUSE

- Any other use is not permitted. The manufacturer accepts no liability for any damages resulting from the proper use. The user is fully liable for any possible risk.
- Any change to the machine relieves the manufacturer from the liability for damage or accidents caused by the machine.

OPERATION OF THE MACHINE

The machine is designed for only one operator. Any other person standing nearby may lead to a safety hazard for the user and other persons.

ACCESSORY ON THE MARKET (ONLY IF AUTHORIZED)

Only such accessories may be used that are authorized by the manufacturer. For any other use for which no authorization is given, or for any misunderstanding in this manual, please contact the technical division of the manufacturer.

BARBIERI s.r.l. - Technical division

36040 SOSSANO - (VI) - ITALY

Tel: 0444/885722 - Fax: 0444/885482

E-mail to support@barbieri-fb.com

The manufacturer is not liable for the descriptions, figures and technical features mentioned herein.

They are only indicated as information. The manufacturer reserves at all times the right to modify the product without prior notification, with the aim to improve the product quality and without updating this publication.

C - CONTENTS**MACHINE IDENTIFICATION**

- o Chassis number
- o Motor rating plate
- o Dimensions

SECTION 1 - TECHNICAL DATA

- 1.1 Technical data
- 1.2 Noise
- 1.3 Oscillations

SECTION 2 - SAFETY RULES

- 2.1 Protective equipment
- 2.2 Safety devices

SECTION 3 - PREPARATION OF THE MACHINE

- 3.1 Equipment and packaging
- 3.2 Before commissioning

SECTION 4 - OPERATING ELEMENTS

- 4.1 Nomenclature of most important components
- 4.2 Motor
 - 4.2.1 Air filter
 - 4.2.2 Fuel tank
- 4.3 Cutting deck
- 4.4 Electric system
- 4.5 Drive
- 4.6 Remote control

SECTION 5 - SAFE USE

- 5.1 Connection of radio control
- 5.2 Motor start
- 5.3 Motor stop
- 5.4 Start up
- 5.5 Start up on a track
- 5.6 Brake system and parking
- 5.7 PTO shaft (switching on the cutting blade)
- 5.8 Height setting adjustment
- 5.9 Auxiliary port
- 5.10 Control during use
- 5.11 Access to and from the working field
 - 5.11.1 Loading and unloading a truck
- 5.12 Safety in the working area

SECTION 6 - TROUBLESHOOTING**SECTION 7 - MAINTENANCE**

- Main maintenance points
- Lubrication points
- Wiring diagram
- 7.1 Before use
 - 7.1.1 Checking the motor
 - 7.1.2 Motor air filter
 - 7.1.3 Fueling
 - 7.1.3 Checking the crawler tension
 - 7.1.4 Radio control battery level
 - 7.1.5 Checking the cutting blades
- 7.2 Maintenance and setting
 - 7.2.1 Maintenance scheme and lubrication scheme
 - 7.2.2 Changing the oil and filter
 - 7.2.3 Checking and exchanging the gear oil
 - 7.2.4 Lubrication of connections
 - 7.2.5 Air filter cleaning
 - 7.2.6 Blade V-belt setting
 - 7.2.7 Sharpening and exchanging the pendulum blades
 - 7.2.8 Replacing the rubber caterpillars
 - 7.2.9 Battery and remote control
- 7.3 Instruction for disposal

SECTION 8 - CLAIMS AND WARRANTY**SECTION 9 - CONFORMITY DECLARATION**

D - IDENTIFICATION

Please ensure that you have written down the following identification numbers of the machine before contacting the dealer in case of any problem, repair or order of spare parts.

- Model and chassis number
- Motor type and series number

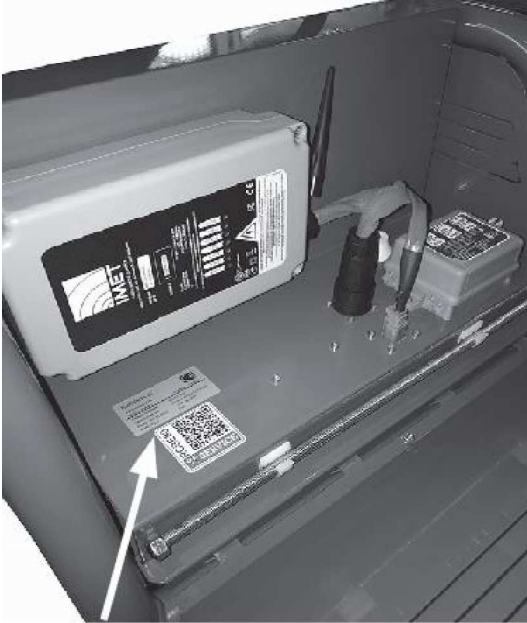

Chassis number



Motor type and number (Vanguard MOTOR)

Dimensions (mm)

Fig 3

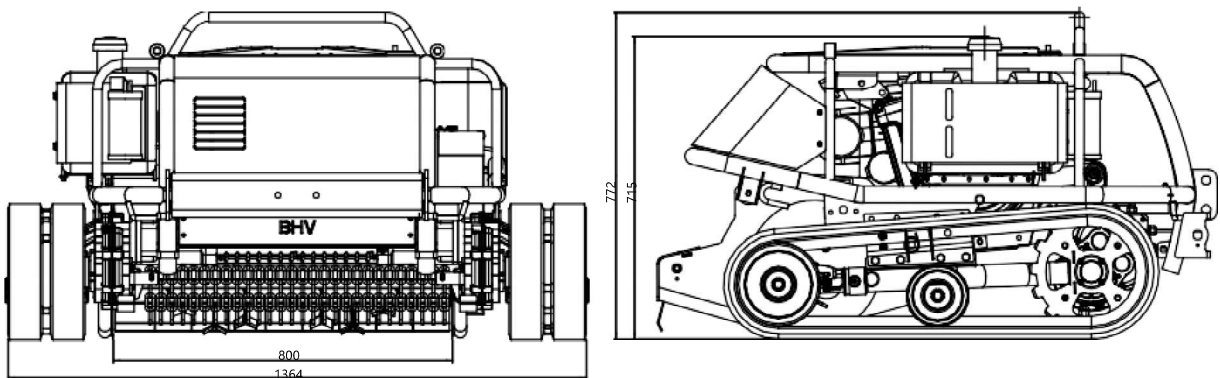

SECTION 1 - TECHNICAL DATA

1 - TECHNICAL DATA

1.1 - Technical data

MOTOR		GENERATOR	
Manufacturer	BRIGGS & STRATTON	Generator 1	3 phases 68VAC - 100A
Model	VANGUARD 3864	Generator 2	Mono phase 13VAC - 10A
Motor type	Air cooled 4S OHV gasoline		
	Pressure lubrication		
Net output	17 kW (23 PS) / 3 600 rev./min	CUTTING DEVICE	
Max. torque	48 Nm / @ 2 800 rev./min	Type	Flail mower Rear discharge
Displacement	627 (2 cylinders) cm ³	Blades	40 Swimming blades-2600 rev./min
Bore x stroke	75 x 70 mm	Working width	80 cm
Ignition system	Electronic ignition	Height adjustment	30-150 mm stepless electric
Start system	Electric START	Power transmission	For belt EM clutch (Ogura)
Air filter	Air filter paper + Foam cartridge		
Fuel tank	15 L	REMOTE CONTROL 2.4 GHz	
Fuel consumption	3.5 L/St - 3 000 rev./min	Radio Technology	AFA (Aut. Freq. Setting)
Motor output	1.7 L	Joystick	Optic - touchless
		Radio transmission	150 m remote
		Specifications compl.	Directive R&TTE 1999/5/CE 2006/42/CE PLe class 4 /SIL 3 ISO 13849-1:2008 / EN62061:2005"
	Swimming blades		
		Weight	1.3 kg
TRANSMISSION		DIMENSIONS	
Type	Hybrid electric motors 48V with reduction gear	Total dimensions	1324 x 1364 x 772
Control	Stepless electric	Weight	430 kg
Speed control	0-8 km/h	Ground pressure	166 g/cm ²
Slope capability	35° Uphill - Lengthwise 45°	Caterpillar contact face	(17.5x74x2) = 2590 cm ²
Angle / Gravity point height	65° / 18cm		
Motor type	Brushless perm. magnet		
	3 phases		
Motor output	2 kw		
Control system	BHV - 48V 60A		

2 - SAFETY RULES

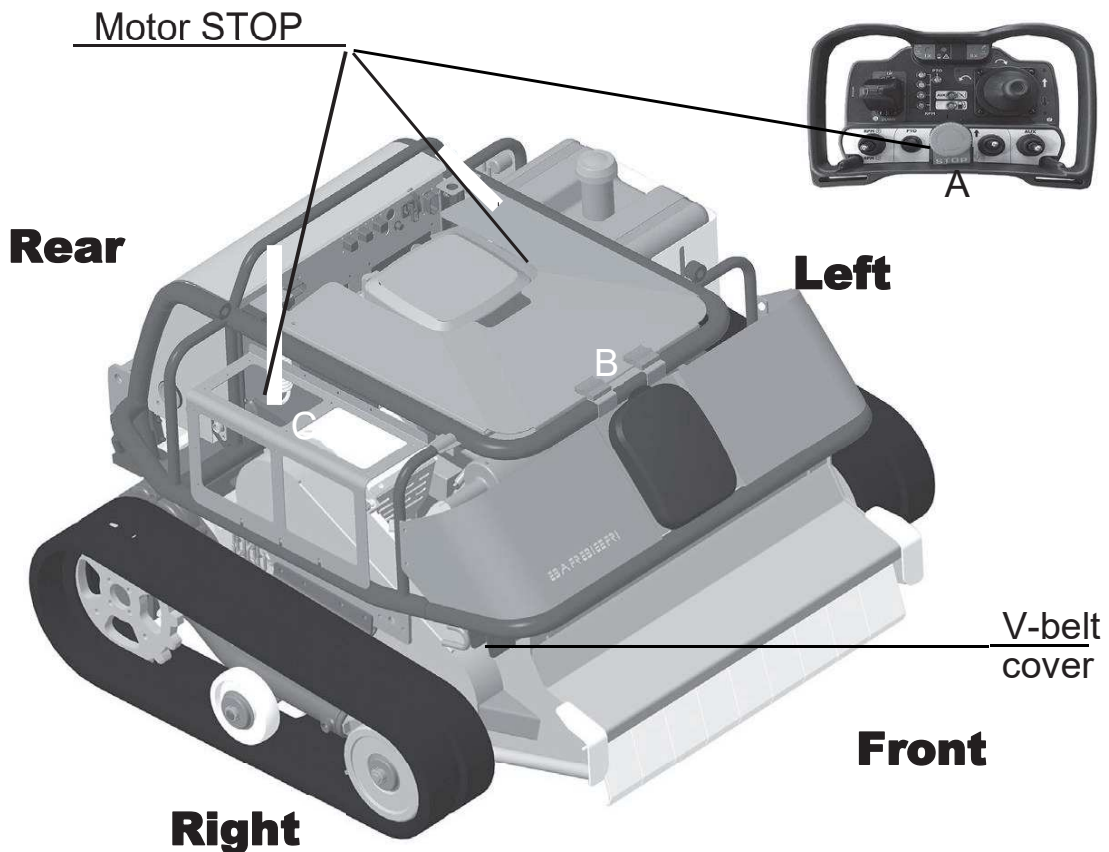

Fig 5

2.1 - SAFETY EQUIPMENT

The terms „FRONT“ - „REAR“ - „RIGHT“ - „LEFT“ that are used in this manual and in the spare part catalogue, refer to the machine as shown in Figure 5.

SAFETY DEVICES

The machine is provided with a series of safety devices according to the machine directive.

In detail, the following devices are prepared:

- 1 - Motor stop device (B) (Fig.5)
- 2 - Motor STOP on remote control (A) (Fig.5)
- 3 - Motor stop at start key (C) (Fig. 5)
- 4 - Automatic brake system at motor standstill
- 5 - Front and rear protective plate for the protection of ejected parts
- 6 - Automatic switch-off of the pendulum blades at motor stop
- 7 - Automatic motor stop in case of loss of radio control
- 8 - Drive belt cover

The most important warning signs are found near the dangerous area around the machine. Ensure that you understand the meaning of the warning signs to guarantee the orderly behavior of the machine and to prevent any dangerous operations.

These warning signs are very important for the all-time safe implementation of the machine. Maintain the warning signs in clean and good condition. In case of damages or absence of any sign, the replacement of a new one is mandatory.

PRECAUTION LABEL AND WARNING INSTRUCTION

Next to the CE-marking, safety pictures and instructions are affixed onto the machine as shown in Fig. 4.

WARNING: BEFORE COMMISSIONING

Read thoroughly the technical instructions in the operating manual before commissioning the machine.



WARNING: HAZARD OF INJURY

When the blades are switched on, maintain a safe distance from the ejection side of the flail mower, since stones or other hard objects may be expelled from the machine. You may be hit and injured.



If necessary, use safety goggles to protect against flying objects.



WARNING: FOLDING HAZARD

Keep a safe distance from a running V-belt



HAZARD FOR FEET AND HANDS:

Pendulum blades: Watch out for your hands and feet.



WARNING:

Machine is remotely controlled. Maintain a safe distance when the motor is running



WARNING:

Crushing hazard for hands



WARNING:

Exhaust gases are toxic! Never start a motor in a closed room



WARNING:

Gasoline gases are explosive Never refuel if open flames, sparks or smoking



WARNING:

Do not work on slopes or precipices beyond the maximum capacity. The stability and motor lubrication may be lost.

WARNING:

Do not work on slopes or precipices beyond the maximum from above, because this can be very dangerous.



- 1) Before starting the motor, ensure the proper operation of the SAFETY DEVICES. This allows the operator to work safely in hazardous situations.
- 2) This device may only be used by an operator using remote control. Any other use is not permitted!
- 3) It is important to maintain a safe distance between the operator and the machine in the working area (see chapter 5.12).
- 4) Before commissioning the machine, read thoroughly the usage instructions so that you are familiar with all operating elements and safety features of the machine.
- 5) Retrofitting the machine or the use of non-original parts is not allowed without the prior authorization from the manufacturer. This practice may lead to extremely hazardous and unforeseen situations and makes the warranty void.
- 6) Never transport any person or objects on the machine.
- 7) Before using the machine, check that all controls are in order.
- 8) Move the control elements step by step. A sudden sudden engagement may cause the machine to lose stability.
- 9) Always check whether all parts are fastened correctly.
- 10) This machine may not be used by children or inexperienced persons. Nor by operators that are not sufficiently trained, are affected by alcohol or other substances.
- 11) Before commissioning the machine, check that the green surfaces are free from any debris and that no one is standing in the working area (hazardous area). The operator is responsible for the safety of third parties when they are standing in the working area. Never use the machine in such conditions.

- 12) Never use the machine if you are tired.
- 13) Always keep a safe distance from the cutting blades during the operation of the machine.
- 14) Only use original spare parts and accessories to guarantee the safety and proper functioning of the machine.
- 15) Stop the motor before refueling.
- 16) Handle the fuel carefully to prevent spilling. Clean fuel spillage immediately.
- 17) Do not overfill the tank.
- 18) Plan your work before starting.
- 19) During slanting work, the operator must always be at the rearmost position of the machine. Driving the machine from above is normally very dangerous.
- 20) The area next to the motor exhaust gases most probably temperatures higher than 80 °.



ATTENTION! Scalding hazard.

- 21) Keep the working area free and clean.
- 22) Only use the machine with good visibility.
- 23) If you hit an object during your work, stop the machine and check for any damages.
- 24) It is advisable to have first aid equipment available
- 25) The speed of the machine must correspond to the environmental conditions.
- 26) Never perform maintenance or cleaning work when the motor is running.

SECTION 2 - SAFETY RULES

- 27) If possible, prevent working down or uphill. Always drive crossways to the slope.
- 28) Never work on slopes above 70%.
- 29) Keep hot machine parts clean (cylinder head, exhaust pipe etc.) during operation, in order to prevent any debris that may overheat the motor.
- 30) If possible, stop the machine on level ground.
- 31) Position the machine so that children or inexperienced persons cannot reach it: Stop the machine and remove the key from the ignition.
- 32) Do not leave the machine when the motor is running. Reach level ground and switch off the motor.
- 33) Follow carefully the maintenance instructions and replace any worn out parts, if required.
- 34) Only store the machine after cleaning. Always clean the machine with air.
- 35) If required, follow the specific safety standards applicable in the country where the machine is operated.
- 36) Never refuel in closed rooms, near open flames or ignition sources. Smoking is prohibited when handling fuel!
- 37) Never start the motor in an enclosed location. Exhaust gases contain toxic carbon monoxide, ensure sufficient ventilation when the motor is started in closed rooms.
- 38) After a prolonged storage of the machine, perform a thorough cleaning and lubrication of the machine according to the lubrication scheme.

3 - PREPARATION OF THE MACHINE

3.1 Equipment and packaging



Fig. 6

The machine is supplied with:

- 1 x basic device XFlail
- 1 x radio control
- 2 x lithium battery for radio control
- 1 x charging device
- 1 x hanging strap
- 1 x Operating manual
- 1 x Motor Operating manual
- 1 x Tie bolt (for replacing the caterpillars)

Before commissioning the machine, check the fuel and motor oil fill level and read thoroughly the safety requirements and procedures for the start and operation of the machine.

3.2 BEFORE COMMISSIONING

Before using the machine for the first time, the following checks must be performed:

- Motor oil level (see Chapter 7.1.1)
 - Fuel level (see Chapter 7.1.3)
 - Charging level of the radio transmitter battery (see 7.1.5)
- The motor oil level must always be at the top mark of the dipstick. A lower level reduces drastically the performance of the motor on gradients.
 - The fuel level must be near maximum, but never reach the collar of the tank. In the case of a slope, the fuel may leak and pose a risk of fire.
 - Before starting a new job, both batteries should be charged. For the whole working day one battery must be sufficient, but have always a spare battery available.

4 - OPERATING ELEMENTS

4.1 NOMENCLATURE OF MOST IMPORTANT COMPONENTS (Fig. 7)

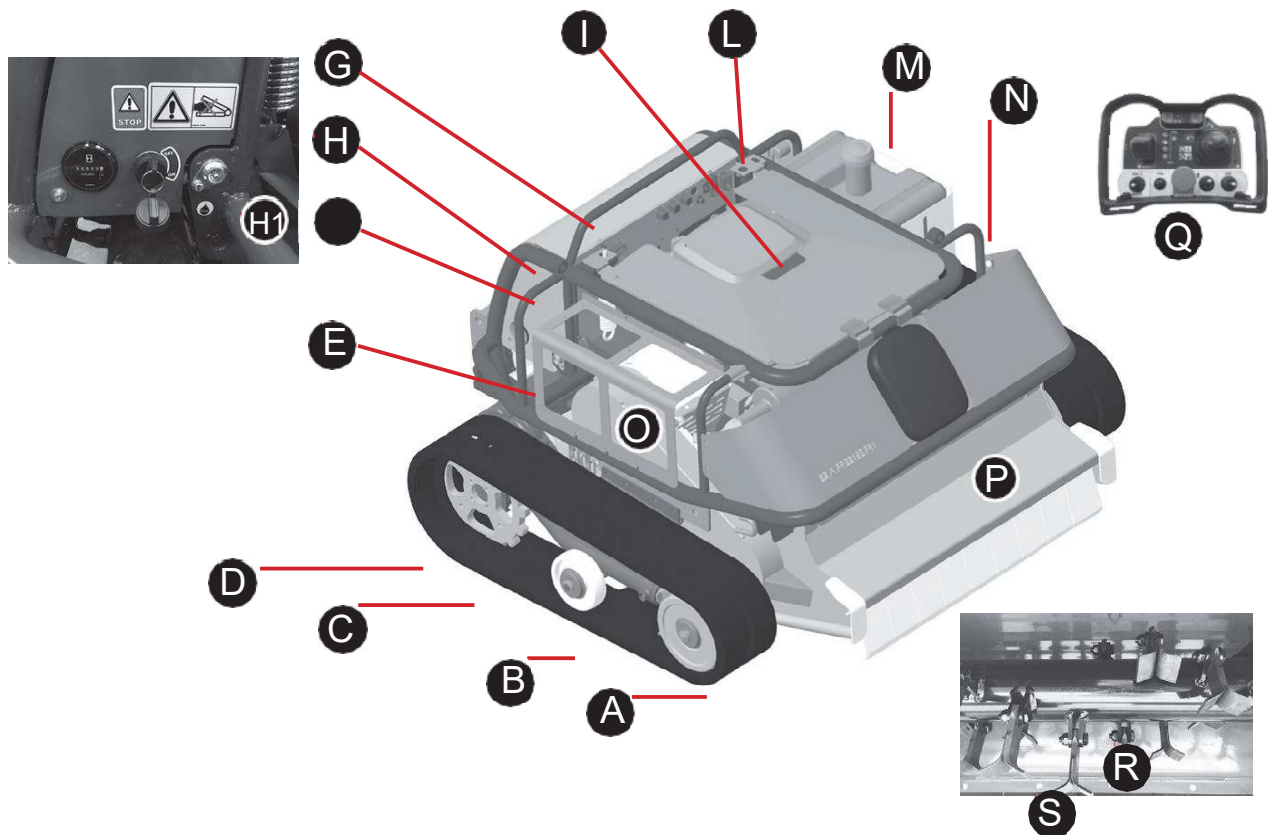

Fig 7

Basic device: Identification of main components.

- A) Tensor wheels
- B) Track roller
- C) Drive wheel
- D) Caterpillars
- E) Drive motors
- F) Electric cabinet

- G) Antenna
- H) Battery housing
- H1) Ignition key
- I) Motor - Air inlet
- L) Emergency switch
- M) Fuel tank

- N) Air filter
- O) Belt cover
- P) Flail mower
- Q) Remote control
- R) Cutting roll
- S) Cutting edge

4.2 MOTOR (Fig.7 - i)

The machine is provided with a high-performance gasoline motor from the USA, so the long service life of the product is guaranteed. The motor is equipped with an electric starter. For starting the motor, see Chapter 5.2 . Although the motor is equipped with forced lubrication, when working on slopes is recommended not to exceed 35°. The working limit angles are indicated on the machine and at the bottom of the remote control.

**IMPORTANT**

Do not park the machine on a slope when the motor is running. The lubrication may prove to be insufficient and can cause the motor to be damaged.

**ATTENTION**

Do not switch off the machine on a slope. Switching off the motor results in the switching off and loss of the brake torque of the motors. The machine could slowly go downhill without any control.

The first 50 working hours constitute the the motor's running-in period. Please note that during this period the machine may not be operated at maximum output. After switching on the machine, the motor must be warmed up in idle. If the machine is operated at maximum output immediately after starting, this will result in thermal shock of the motor components; its service life will be shorter.

4.2.1 AIR FILTER (Fig.7 - n)

The motor is equipped for an air-suction filter. In case of dry grass and dusty environments, frequent cleaning of the air filter is required (every 2 hours). . If dry blades of grass get stuck on to the automatic openings of the motor current generator (Fig. 7 - i), they will probably also be present in the air filter, which must then be cleaned. (see Chapter 7.1.2). A blockage of the air filter may lead to loss of motor performance. Normally, the filter must be cleaned daily.

4.2.2 FUEL TANK (Fig. 7 - m)

The tank can contain 15 liters of fuel, which should be sufficient for 6 working hours. Before starting the task, the tank must be full. A 3 liter fuel reserve is indicated by a red light on the remote control, i.e. this means that refueling is required. Stop the working process and move the machine to level ground for fueling.

4 - OPERATING ELEMENTS

**WARNING**

Always park the machine crossways to the slope. Stopping the motor downhill may be dangerous. When the motor is stopped, the electric motors can no longer be controlled. When the machine is parked downhill, it could move downhill.

**WARNING**

Be careful during refueling: Gasoline is highly explosive. Never refuel when someone is smoking or standing nearby sparks or open fire.

4.3 FLAIL MOWER HOUSING (Fig. 7 - p)

The flail mower housing has a special design for the required output. It is directly connected to the motor by means of a V-belt and separated by an EM-clutch.

The rotor is switched on with the increased speed of the motor. (see Chapter 5.7). The blade system depends on the type of task: Pallet knives for precise lawn cutting and Y-shackle knives specifically for fields with dusty implementation conditions and a stronger material stock of max. 2 cm. The cutting height can be set via remote control. It is visualized via an optical display at the right of the machine (see Fig. 8). For maintenance of the EM-clutch, blades and drive belt, see Chapter 7.2.7.

4.4 ELECTRIC SYSTEM

The drive system of this mower is electric. The 48 V supply produced by the gasoline motor actuated by the generator is within a range (low voltage supply - **ELV**) that prevents the hazard of electric shock.

The caterpillar is then actuated by two brushless electric motors that are electronically controlled by two power inverters according to a well-engineered software enabling the user-friendly and flexible operation of the machine.



Fig 8

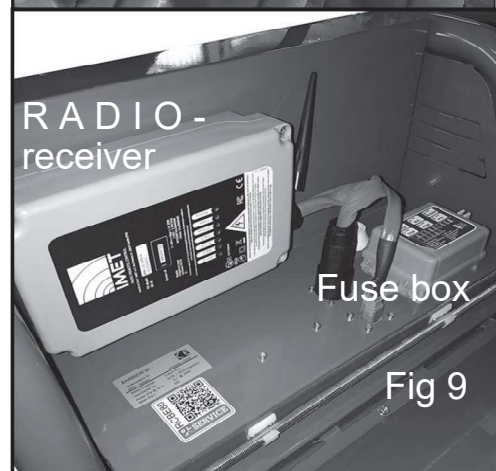

Fig 9

The switching cabinet at the rear of the machine provides easy access to the radio receiver and the fuse and relay boxes (Fig. 9). The electric system is water-resistant according to **IP 54**.

4.5 DRIVE

The power transmission to the caterpillars is performed via a robust and noiseless spur gear. The portal shape of the drive enables a very low gravitation point, with a distance of only 15 cm from the ground. The motor construction technology enables a high torque, even at stillstand. Both features make the machine very suitable for steep slopes, and in case of a power shutdown the passive brake system prevents the machine from losing control and driving it in the direction of the valley.

4.6 REMOTE CONTROL

The remote control has robust and reliable electronics by which the machine can be steered in any direction. It is operated with a frequency of 2.4 GHz and uses Automatic Frequency Adjustment which in case of failure searches for the transmission frequency that is freely available.

OPERATING ELEMENTS OF THE RADIO TRANSMITTER

Fig 10



- | | |
|---|---|
| <ul style="list-style-type: none"> 1 Radio button 2 Button for motor start (with (1)) 3 Motor throttle valve 4 PTO switch 5 Cutting heights-setting handle | <ul style="list-style-type: none"> 6 Drive control F//R. - L/R 7 Setting handle for auxiliary cylinder 8 Reference switch for drive direction 9 Alarm switch (motor stop) 10 Aux socket switch |
|---|---|

5 - SAFE USE

5.1 CONNECTION OF THE RADIO CONTROL

Turn the start key switch to the ON position. The buzzer sounds to indicate that the radio control is not connected. For connection, press once the green key 1 (Fig. 10) at the left of the remote control and wait until both indicator lights flash green (A) and blue (B). Press again the green key 1 (Fig. 10) and release it. The indicator lights should stop flashing and the buzzer sounds. Radio control is now connected

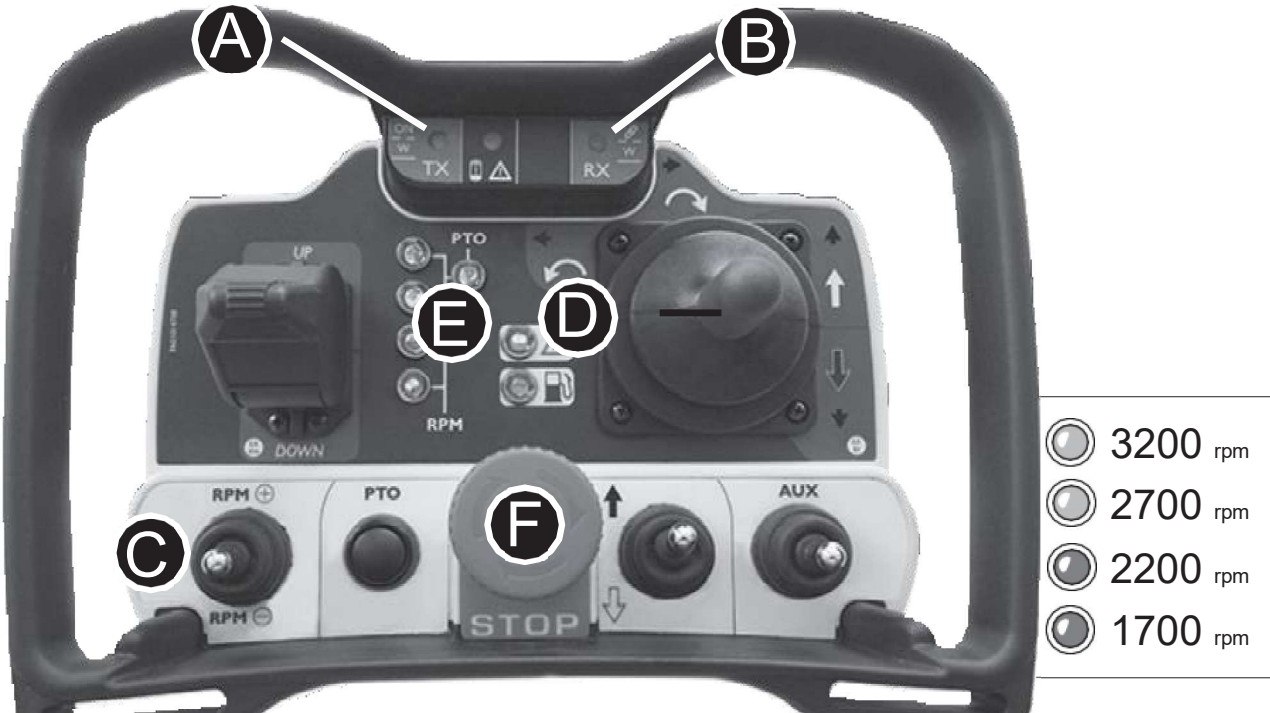

Fig 11

Fig 11b

5.2 MOTOR START (Fig.10 - 11)

Move the gas handle upwards (Fig. 10 (c)) until it cannot go any further. To start the motor at a lower temperature, pull the choke at the middle (Fig. 11b). Press button 2 and then button 1 (Fig. 10(2) and (1)), until the motor is started. Move the gas handle upwards to reach the idle speed and warm up the motor. Now the motor speed can be set and the value is displayed by the warning light column (Fig. 11 (E)).



5.3 MOTOR STOP (Fig. 11)

For switching off the motor, always press the red alarm button (Fig 11 (F)). The motor stops suddenly. Do not forget that shortly after stopping you should release the emergency button to its normal position. The motor can also be switched off by the alarm button on top of the machine (Fig. 7 (L))

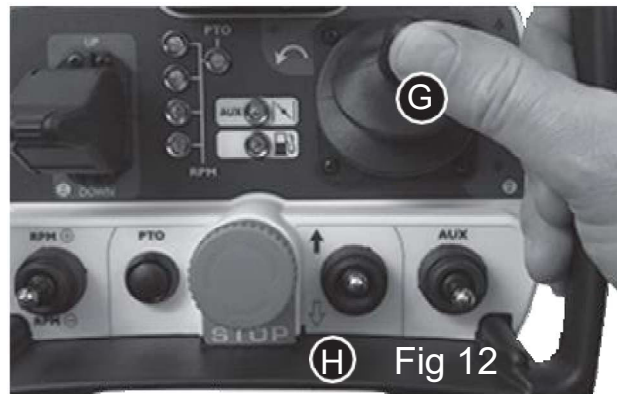

by switching off the star key (Fig, 7 (H1)) or if the connection to the remote control has been interrupted.

NOTICE: If possible, it is recommended to move the machine to level ground before switching off the motor. In an emergency STOP situation start the motor as soon as possible and move the machine to suitable flat ground for parking.

5.4 START UP (Fig.12-13)

Ensure that the handle (H) is set. This handle inverts the movement. Move the joystick (G) little by little (A). The machine drives further. You may **invert** the function of the joystick when the machine approaches you. In this case, the machine moves according to the joystick. The machine is easily controlled with one finger for regulating the speed and direction. The speed is also regulated by the movement of the joystick handle.

Fig 13

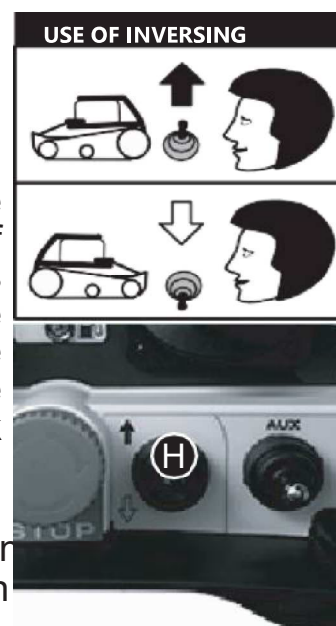

5.5 START UP ON A TRACK

In slope conditions, it is recommended to drive downhill in a longitudinal direction using the left side. For operation slope areas changing direction is not required, since the machine is able to drive in both directions. The recommended path is therefore on to the right side of Fig. 14. If you drive with the left side of figure 14, you will overheat the drive components and the working speed will be much lower.

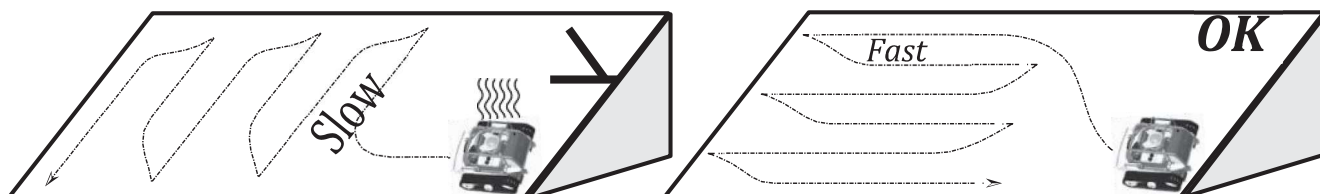

SECTION 5 – INSTRUCTIONS FOR SAFE USE

5.6 BRAKE SYSTEM AND PARKING

The machine is supplied with an automatic E-motor brake which stops the machine when it is not driving. This brake system is operated when the motor is running and all control systems are enabled. In case of danger or any other reason by which the motor is stopped, the brake system is applied. However, it is recommended to move the machine to level ground, if you wish to stop the motor.

5.7 PTO SHAFT (mowing rotor - switch on) (Fig. 15)

When the machine is in the order specified, the mowing blades can be activated.

Starting the shovels requires a great amount of energy, for which a control is provided

in order to prevent the shovel from starting at low motor speed.

Set the motor speed with the throttle (C) at 2800 rev / min (green LEDs (A) - Fig. 15). The green light enables the start of the PTO shaft when pressing the button (B). The green LED (D) indicates the rotation of the blade.

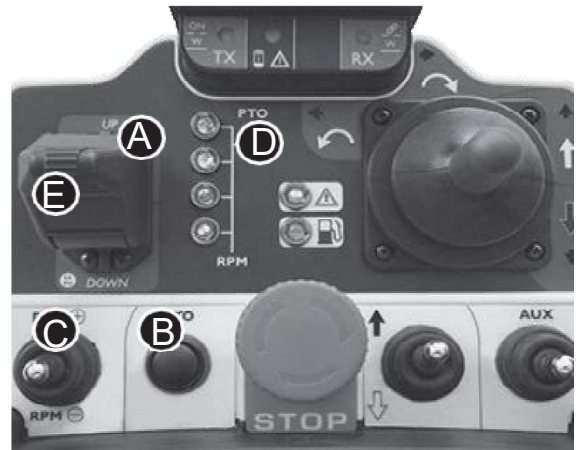

Fig.15



WARNING

Before starting the PTO shaft ensure that all precautionary measures have been taken according to Section 1. 5.10 specifically:

- The blade must be free (not touch the ground)
- No object that the blade can pass through is present in the working area. No persons or domestic animals are standing in the HAZARD AREA (see Section 5.12).

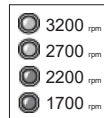

5.8 HEIGHT SETTING ADJUSTMENT (Fig. 15)

It is possible to adjust the cutting height with the remote control at any time. For compact high grass a mowing deck setting of 100 mm from the ground is recommended, in order to let the grass exit. If required, take it to the second level with lower height setting. To lift the blades, move the control handle (e) upwards. To lower the blades, move the control handle (e) downwards.

5.9 AUXILIARY CONNECTION

The machine can be equipped with devices such as a spraying pump, free-cutter, lateral arm, etc. These devices may also be operated by remote control. The devices must be plugged into the socket at the front on the left of the machine (see Fig. 15a).

Fig.15a



5.10 CONTROLS DURING USE

The machine requires only very little maintenance work, due to its maintenance-free design. However, since the machine is equipped with a motor, steering is required as well as some controls for each use of the machine. This machine normally operates in areas that are difficult to access. If the machine is stopped unwantedly, it may be difficult to reach and restore the machine.

Before starting operation, check:

- Everything that was not normal during previous operations.
- Fuel fill level. Refill each time
- Motor oil level: (in the proximity of MAX)
- Clean the air filter cartridge
- Remote control battery charge
- Condition of the blades
- Oil leakage from mower drive housing
- Remove any broken or lost pins and clips
- Residues of grass and mud on the crawler wheels.
- To reduce the hazard of fire and improve the cooling performance, ensure that the motor, the muffler (mufflers), battery area and the area of the fuel tank are free of dirt
- After starting the motor, confirm the actuation of the safety switch.

5.11 ACCESS TO AND FROM THE WORKING FIELD

Special care must be taken during transport and access to the working area.

5.11.1 LOADING AND UNLOADING A TRUCK

For the loading of the front mower onto a truck, switch off the truck's motor, activate the truck's parking brake and block the wheels to prevent any unintended movement of the truck or trailer.

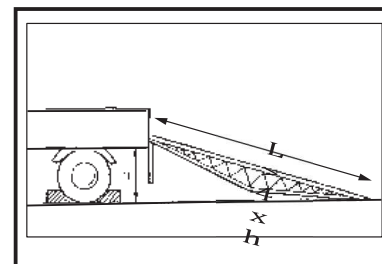

When the machine is loaded onto a truck, lift the moving deck completely and shift forward at a sufficiently low speed. Drive backwards when unloading the machine from the truck or trailer.

Use the ramps with the same or better specifications as indicated below.

Ramp specifications:

- Length more than 4 times the height of the truck platform
- Width (effective width) more than 30 cm
- Required amount 2 ramps
- Capacity (one ramp) more than 250 kg
- Ramps must have slip-resistant surfaces.

SECTION 5 – INSTRUCTIONS FOR SAFE USE

Park the truck on hard and level ground. Hook the ramps safely on the platform of the truck with the platform of the truck at ramp level. at ramp level.

Attach the machine to the truck or trailer by the attachment points in Figure 17.

The machine is made ready using of suspension hooks which are positioned on the working platform of a truck-mounted crane. The machine weight is 370 kg. Use belts and hooks with the correct loading capacity.

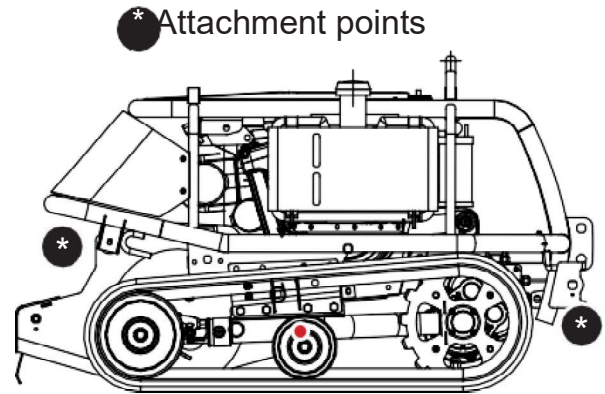

Fig 17

Gravitation point

5.12 SAFETY IN THE WORKING AREA

Following these rules is mandatory to prevent any danger for the operator and persons, domestic animals or any other objects in the vicinity of the operating area.

- a) Only operate the device if it is possible to control the area around the machine within a radius of 20 m. If the movement range of the machine is not observable, change its position. Ensure that no persons or
- b) Fig. 18 animals are near the machine. A drive failure may lead to severe damages to persons, or someone may be hit by an object that is ejected from the mowing knives. The **hazard area** is displayed in Fig. 19.

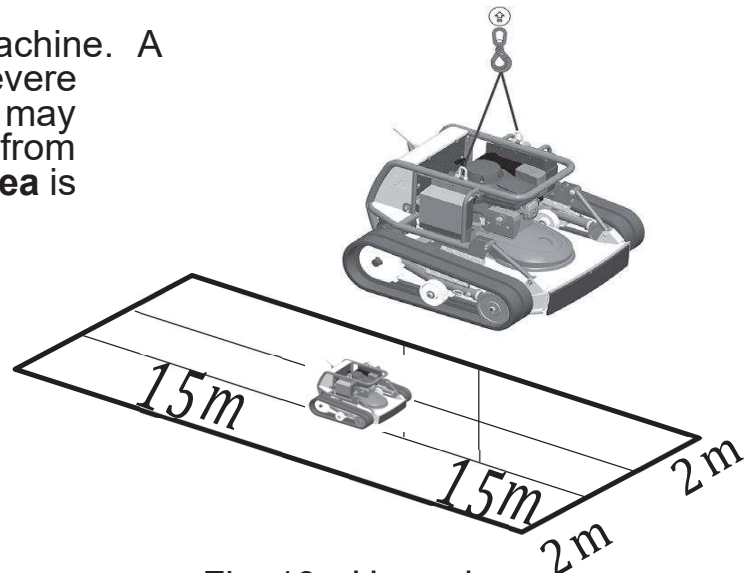

Fig. 19 - Hazard area



WARNING

Never allow any one in the HAZARD AREA.

This recommendation also includes the operator. The machine in motion may be the cause of severe injury.

- c) Check the working area to remove all objects that may be dangerous for the machine.
- d) Put a warning tape or sign to indicate that persons may not enter the working area.
- e) Check the gradients and soil condition to identify any hazard areas. Check the operating position for optimum sight and safe location.
- f) Do not perform maintenance works in the working area, since it is a dusty place. There is also a risk of inordinate efforts and you do not have the required tools available.

FAULT SOLUTION

DEVICES	PROBLEMS	CAUSE	LEGAL MEANS
Remote control	No connection with remote control	Starter key is not in the ON position	Switch starter key to ON
		Emergency stop is not released	Release the emergency stop
		Remote control battery is too weak	Replace the battery and charge remotely
		If the lights on the remote control do not flash, check the fuses	Replace the internal fuse
Power supply	No signal sound when key switch is activated	<ul style="list-style-type: none"> - Battery fuse has burnt - Fuse 1 in fuse box has blown - Battery voltage is too low 	<ul style="list-style-type: none"> - Replace the battery fuse in the battery box - Replace fuse 1 in the fuse box - Charge the battery
Motor	Motor does not start	<ul style="list-style-type: none"> The starter does not function - Choke is not activated - Starter relay has blown - Starter fuse (FUSE 1) has blown 	<ul style="list-style-type: none"> - Activate the choke handle. - Replace the starter relay (E) - Replace fuse 1 "
		Starter rotates but motor does not start	<ul style="list-style-type: none"> - Check fuel level - Check radio condition - Check fuel circuit - Check motor oil level - Check and clean the air filter
		No fuel in carburetor	<ul style="list-style-type: none"> - Defect fuel pump - Defect fuel pump - Crushed fuel line - Loose clamp
	Gas does not work	<ul style="list-style-type: none"> - Gas handle does not move 	<ul style="list-style-type: none"> - Check cable XC3 - Check fuses 7 and 8 - The drive is defect
		<ul style="list-style-type: none"> - Gas handle moves 	<ul style="list-style-type: none"> - Check the connecting rod
	Motor stutters and exhaust smoke is generated	Choke handle clamps in active position	Reduce the motor speed until the choke warning light turns off
Motor start and stalls- Exhaust smoke is generated	Oil level to high	Check the oil level and possibly drain the oil	
Driving	Device does not respond to remote control	One driver unit is not synchronized with the other one	Key start to OFF and restart
	Device does not drive	Connection cable between the driver units is disconnected	Check the connection between the driver units
		Big fuse has blown.	Replace the defective fuse
		Emergency brake cable is not connected	Reconnect the emergency brake network cable
Height adjustment	Electric height adjustment does not work	<ul style="list-style-type: none"> The actuator does not function 	<ul style="list-style-type: none"> - Check cable XC1 - Check fuses 5 and 6 - Actuator defective - Check connection cable
		<ul style="list-style-type: none"> - Drive moves 	<ul style="list-style-type: none"> - Check the connecting fork
Flail mower deck	High vibrations and mechanical noise	Blade wings are broken and bent	Stop the device and replace the blades

7 - MAINTENANCE

Main maintenance points

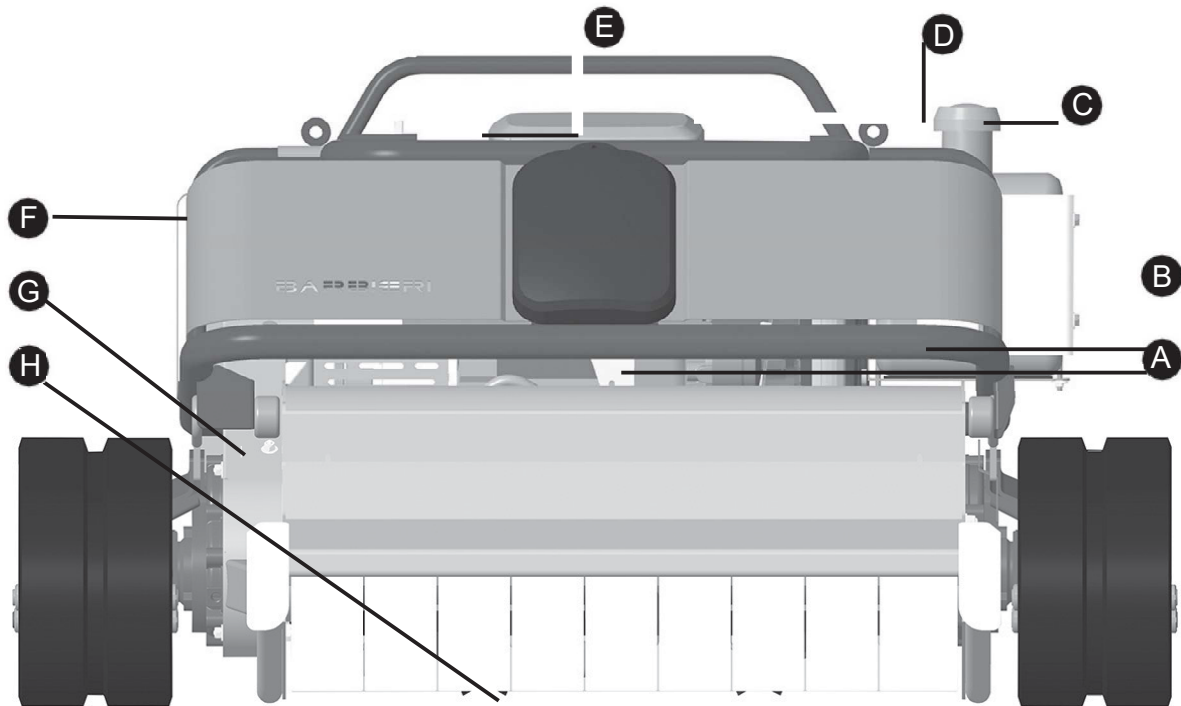
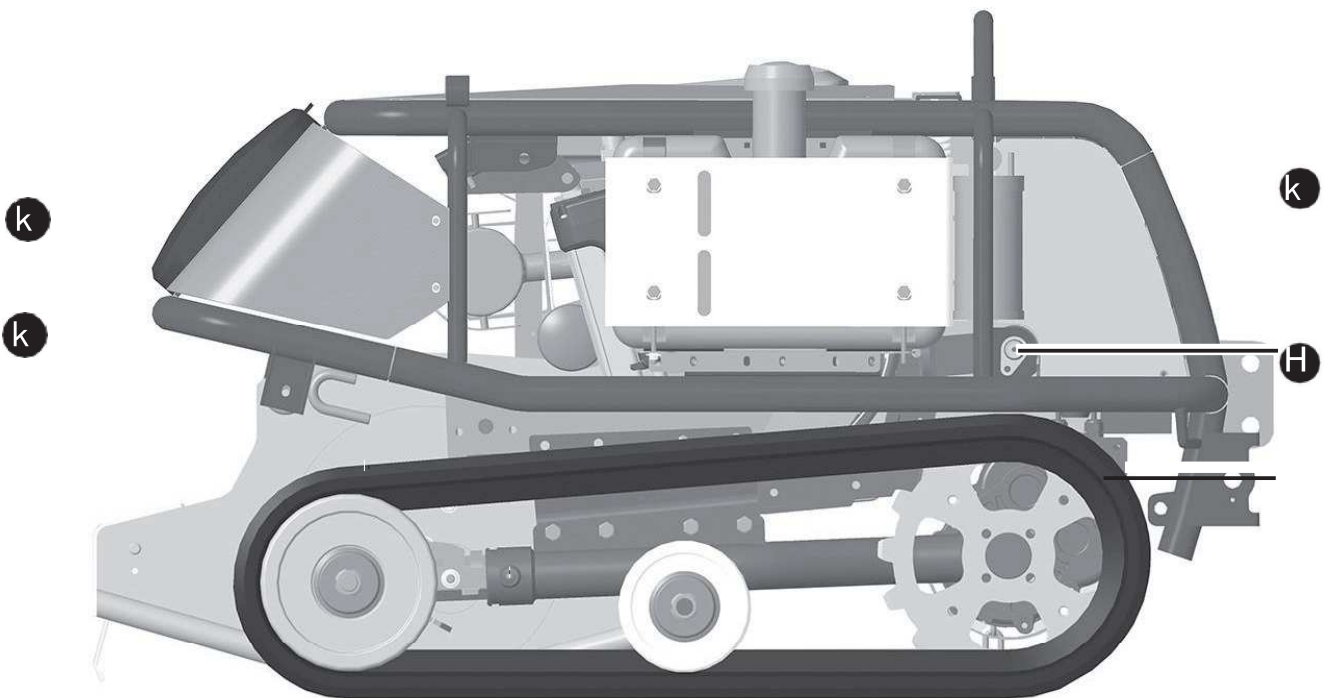

Fig 20

- A) Motor oil drain cap
- B) Fuel filter
- C) Tank cap
- D) G) Moving blade belt
- E) Air filter
- H) Mover blade

- E) Motor oil filling cap
- F) Battery



Lubrication points

- k lubrication nipple
- H reducing oil - filling cap

Fig 21

Electric diagram

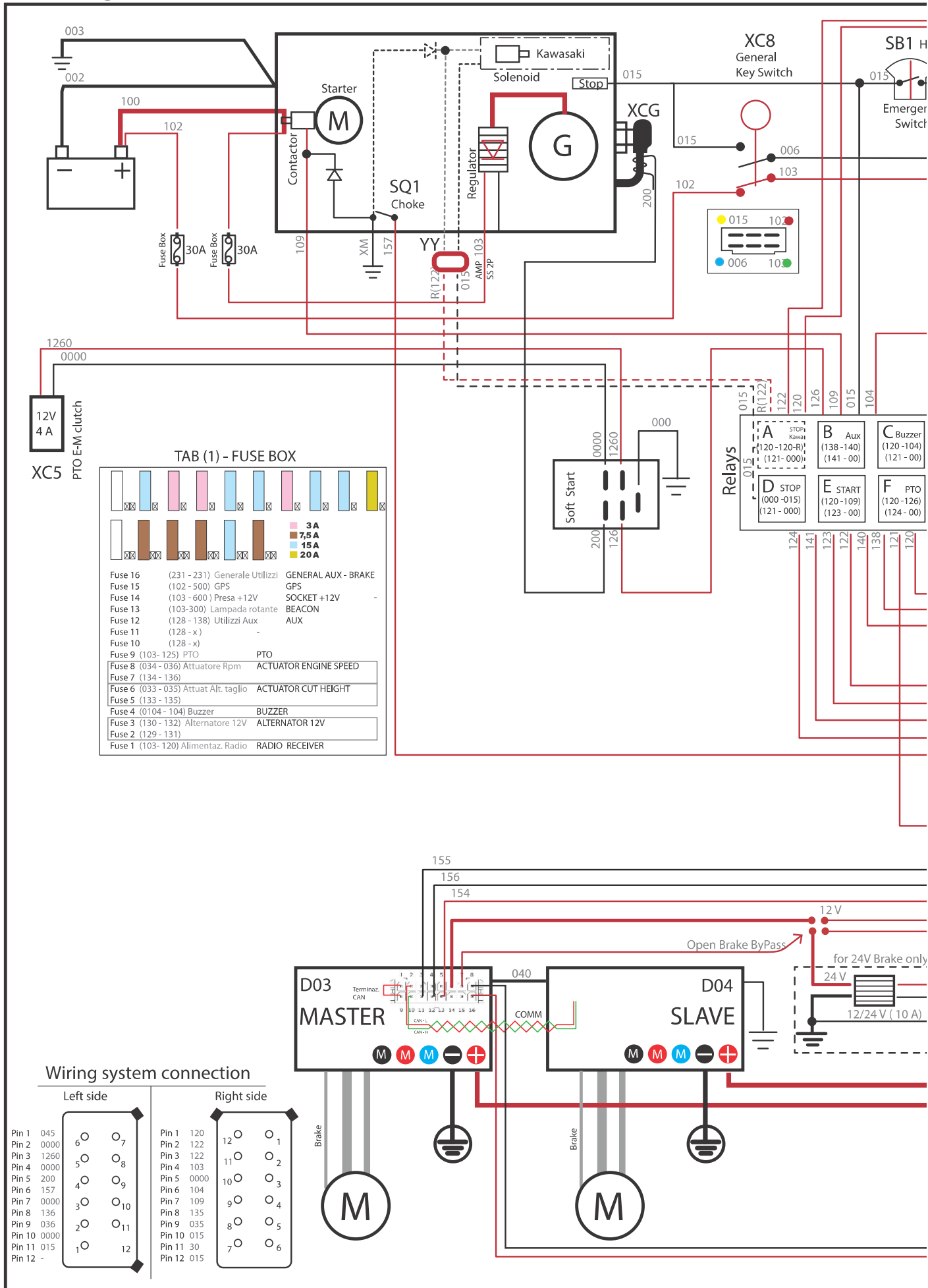

TAB (1) - FUSE BOX

Fuse 16	(231 - 231) Generale Utilizzi	GENERAL AUX - BRAKE
Fuse 15	(102 - 500) GPS	GPS
Fuse 14	(103 - 600) Presa +12V	SOCKET +12V
Fuse 13	(103-300) Lampada rotante	BEACON
Fuse 12	(128 - 138) Utilizzi Aux	AUX
Fuse 11	(128 - x)	
Fuse 10	(128 - x)	
Fuse 9	(103-125) PTO	PTO
Fuse 8	(034 - 036) Attuatore Rpm	ACTUATOR ENGINE SPEED
Fuse 7	(134 - 136)	
Fuse 6	(033 - 035) Attuat Alt. taglio	ACTUATOR CUT HEIGHT
Fuse 5	(133 - 135)	
Fuse 4	(0104 - 104) Buzzer	BUZZER
Fuse 3	(130 - 132) Alternatore 12V	ALTERNATOR 12V
Fuse 2	(129 - 131)	
Fuse 1	(103- 120) Alimentaz. Radio	RADIO RECEIVER

Wiring system connection

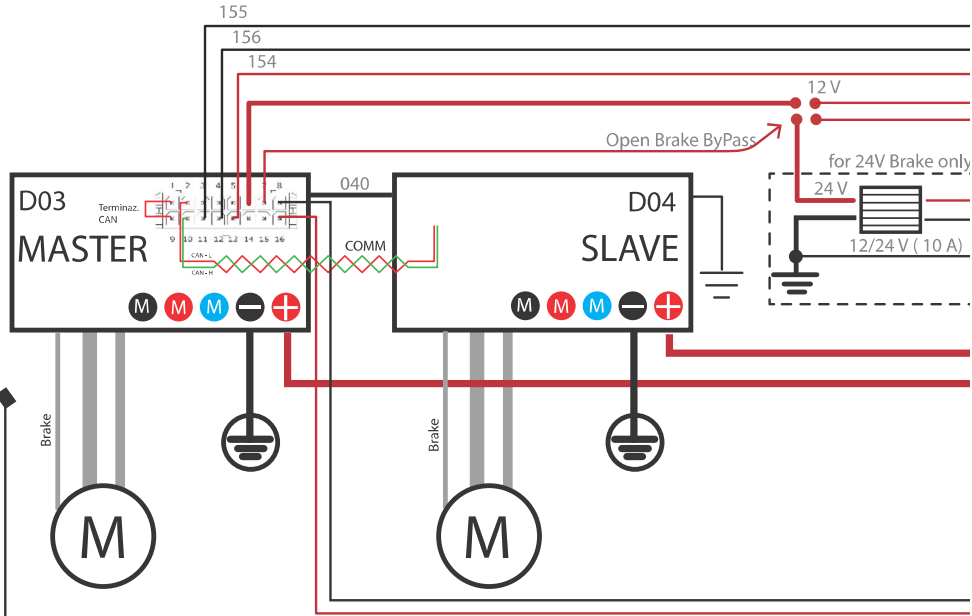
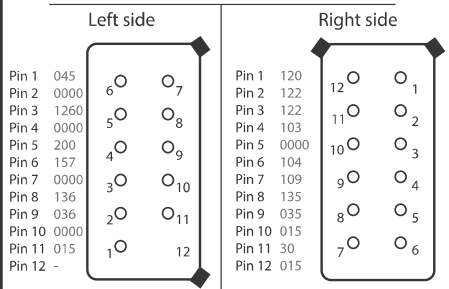

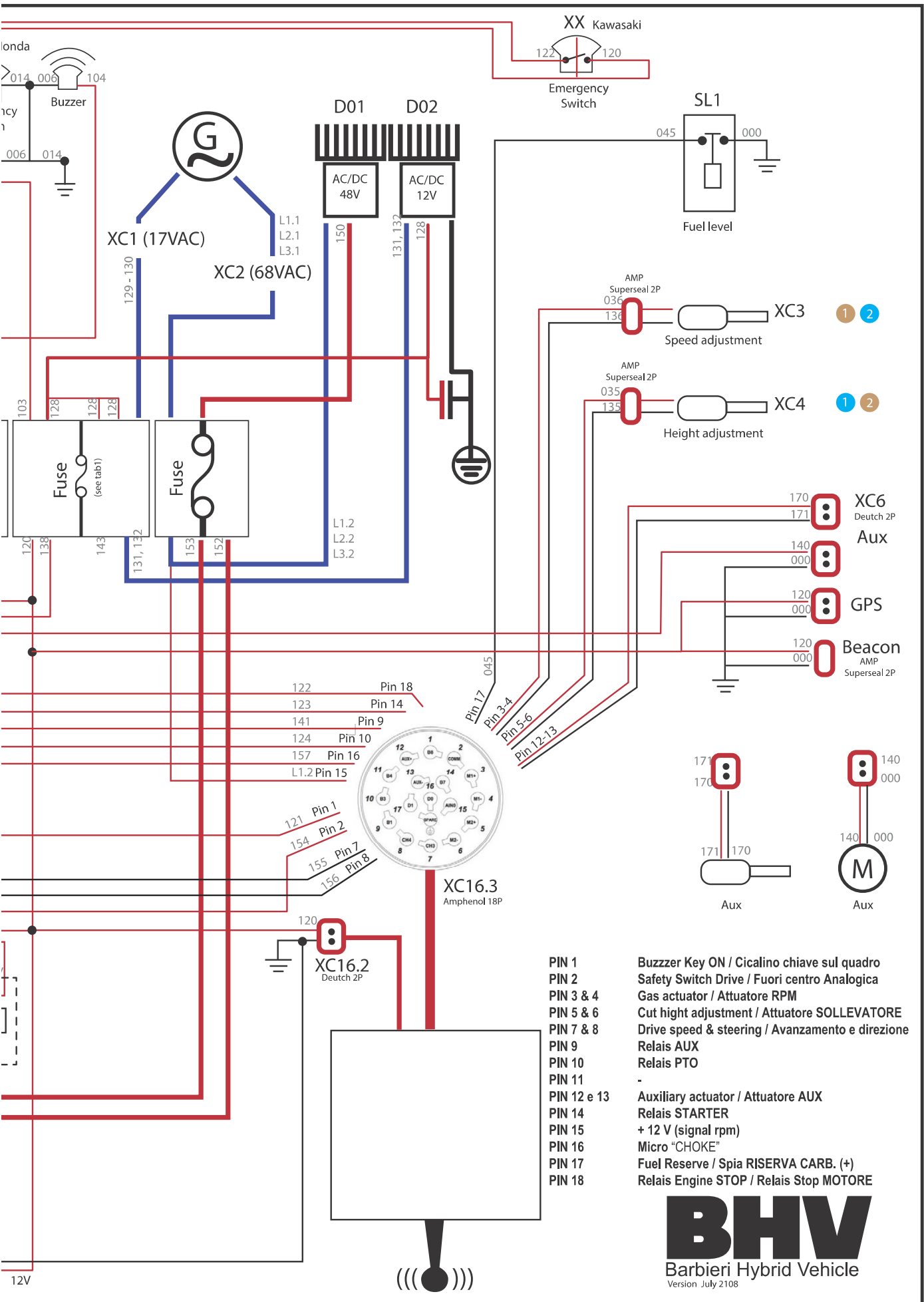

- PIN 1 Buzzer Key ON / Cicalino chiave sul quadro
- PIN 2 Safety Switch Drive / Fuori centro Analogica
- PIN 3 & 4 Gas actuator / Attuatore RPM
- PIN 5 & 6 Cut hight adjustment / Attuatore SOLLEVATORE
- PIN 7 & 8 Drive speed & steering / Avanzamento e direzione
- PIN 9 Relais AUX
- PIN 10 Relais PTO
- PIN 11 -
- PIN 12 e 13 Auxiliary actuator / Attuatore AUX
- PIN 14 Relais STARTER
- PIN 15 + 12 V (signal rpm)
- PIN 16 Micro "CHOKE"
- PIN 17 Fuel Reserve / Spia RISERVA CARB. (+)
- PIN 18 Relais Engine STOP / Relais Stop MOTORE

BHV
Barbieri Hybrid Vehicle
Version July 2108

7.1 TESTS BEFORE USE

7.1.1 Motor oil check oil (Fig 20 (e))

For checking the motor oil the machine must be positioned on flat and hard ground. Remove the oil dipstick (e) and check that the oil level is near the upper marking. Further information on the motor lubrication can be found in the motor manual



IMPORTANT

The oil level may never be below the MIN marking

and not exceed the MAX level at the dipstick.
Overfilling the oil can damage the motor.

Fig. 22

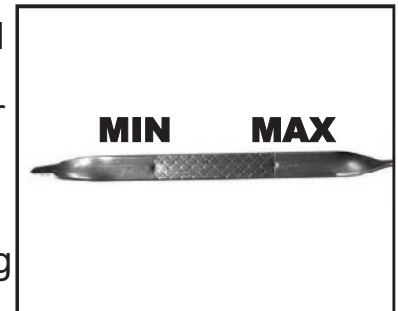

7.1.2 Motor air filter (Fig. 20 (d))

For the proper functioning of the motor it is important to check that the motor's air filter or cooling elements are free from stubble blockages. Frequently clean these elements under dusty and dry conditions.

7.1.3 Fueling (safety instructions see Chapter 4.22)

Refueling onsite is often not simple nor safe. It is therefore strongly recommended to check the fuel tank's fill level before starting work. A full tank allows for 4 hours of work.

7.1.4 Checking the crawler tension and conditions

It is important to check the condition of the caterpillar rubber tracks in order to prevent them from coming off the roller. The crawlers are equipped with an automatic tensioner for exerting the proper force on the rubber track. If during this check a track piece is missing, check whether the crawler rim is damaged or the front wheel tension is inhibited.

A lost crawler rubber part may easily come out of place.

7.1.5 Radio control battery level

The radio control battery is a critical part of the machine. A weak battery impedes the control of the machine. For this reason, 2 batteries are provided to ensure safe operation. It is strongly recommended to charge both batteries before operation.



WARNING

If the battery is weak, the motor may stop.



Fig 23

7.1.6 Checking the cutting blades

The blade rotates at high speed with the result that uncommon wear or a damaged blade may cause the machine to vibrate severely. Also when hitting a stone or any other hard object in the field, the blade may lose its sharpness. Therefore, the condition of the blade must be checked prior to operation.

7.2 MAINTENANCE AND SETTING

7.2.1 Maintenance scheme and lubrication scheme

7.2.2 Changing the oil and filter

Always check the operating manual of the motor manufacturer for the motor oil. The first exchange of oil must take place after the first 50 hours of operation, which is the start-up time of the motor. By this change the airborne particles produced by the rotating parts are removed. Let the motor run for some minutes in order to warm up.

		Replacement or maintenance must be performed by an authorized workshop					
		Clean or wash					
		Check, possibly refill					
		Replace					
		Before	First 50 h	Every 200 h	Every 500 h	Prolonged parking	Remarks
Regular maintenance interval	Motor oil	m	l	l	l	l	Maintain oil level
	Air filter	s	s	s	l	s	
	Fuel	m				m	Fuel tank must always be full
	Fuel filter				l		Avoid dirt/water
	Battery charge level			m		m	
	Rubber tubing			m		m	
	Battery remote control	m				m	Recharge after 3 days
	V-belt mowing drive		m	m	l	m	Adjust V-belt tension
	Blade edge condition	m		m		m	Sharpen the edge
	Gear oil				M		
	Crawler rubber condition	m				m	
	Lubricate		m	m	m	m	
	Fastening screws	m	m	m	m	m	
	Electric system					s	
	Safety switch	m		m		m	

Before checking the fill level or changing the oil, a thorough cleaning must be performed in order to prevent foreign bodies from entering the housing.

Remove the cap with the dipstick (1) and drain cap (2). Collect the exhaust oil in a basin. Pour the old oil into a proper container for disposal. Close the end of the drain cap with new oil from the cap (1). SAE 10W-30 is recommended for general temperature. Other viscosities as indicated in the table may be used, if the average temperature in your area remains within the indicated range. The oil type of the motor is (Agip Rotra MP) (SAE 10W / 30). The amount is 2 L.



Check the oil level as in chapter 7.1.1. Fig 24

723 Checking and changing the gear oil The gear oil must be changed after 500 operating hours, provided there is an oil leak on the gear. In this case, the damaged gasket must be repaired and the oil replaced. This repair must be performed by an authorized dealer.

724 Lubrication of connections

Grease the connection as marked in Fig. 21

after the first 50 and 200 operating hours according to the lubrication scheme.

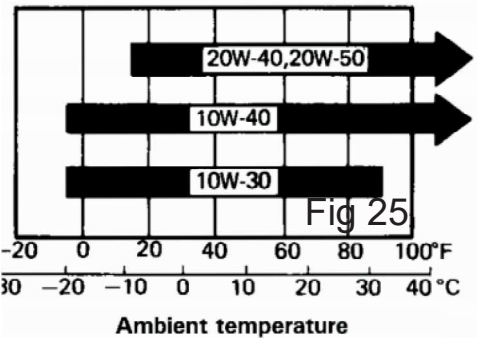

725 Air filter cleaning (see Chapter 4.2.1)

Always clean the air filter and the air inlet of the motor. This measure protects the service life of the motor and guarantees high efficiency and minor fuel consumption. Turn the 2 wing screw. Pull the element out of the air filter. The filter contains 2 elements: a sponge and a paper filter element.

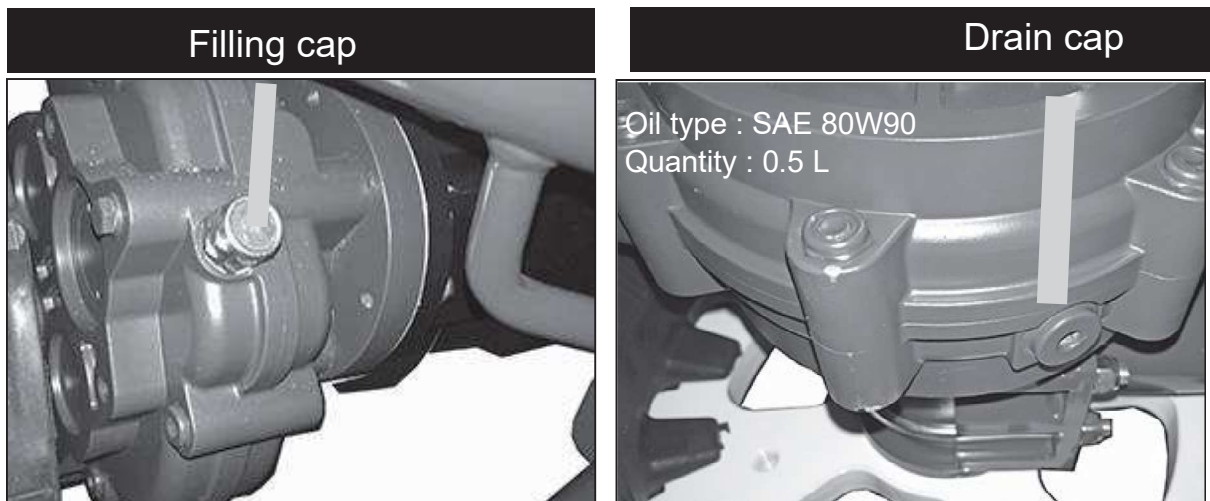

Fig 26

Remove all grass particles from the mandrel and wash (if required) the mandrel. Wipe off the paper filter, while holding it lightly in one hand. If the element does not get clean by tapping, blow it off with compressed air. Apply compressed air from the inside to the outside.

After cleaning, install the element in inverse order.

IMPORTANT

Never hit the element against a hard object such as a concrete wall. Replace any element that has been washed five times or that is damaged. Never try to start the motor without the air filter element. Doing so results in motor failure.



726 Blade V-belt setting

The blade V-belt may change its dimensions after several hours. It is therefore recommended to set the belt tension in accordance to the maintenance scheme in Chapter 7.2.1.

Remove the belt cover for the adjustment of the belt. Check the tension applying a force of 5 kg on the belt. The bending depth of the belt may not exceed 10 mm.

If required, adjust the belt tension in accordance with this manual (Fig. 29).

- Loosen the nuts (1) of the motor carriage
- Loosen the safety nuts (2)
- Set the tension with the screws (3)
- Lock the position with the nuts (2)
- Fix the position of the motor carriage (1)

If the belt must be replaced, remove the cover plate below the mowing deck (see Fig. 30).

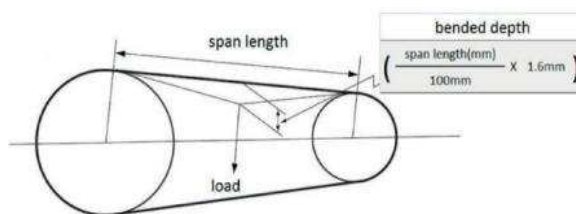
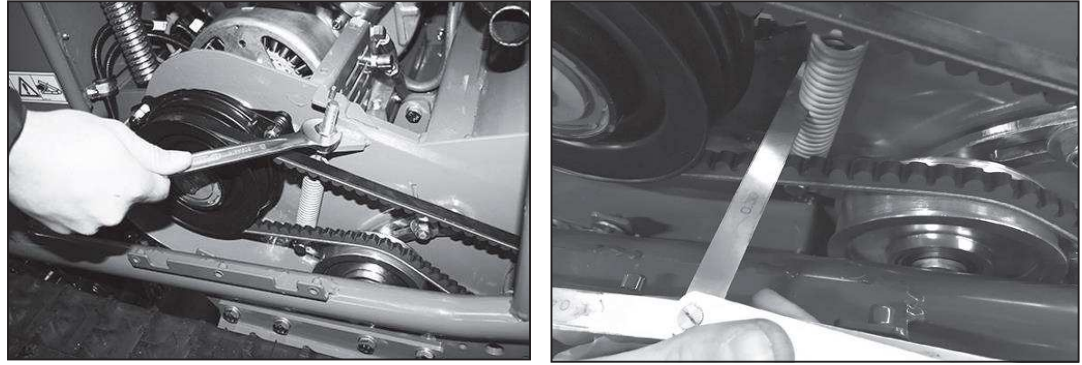

Fig 28

Fig 29



727 Sharpening and replacing the pendulum blades

The pendulum blades of this mowing machine rotate very fast; the unbalance produced by slight damage to a single blade may result in excessive noises and vibrations.

Check the condition of the blades each time uncommon noises occur.

For an easy inspection and removal of the blades, lift the front part of the machine using a crane in vertical position. Secure the machine with a support.

Unscrew the middle screw to remove the blade support.

- Make sure that the blade can rotate easily.
- Sharpen the blade simultaneously. The weight of the both blades must be the same.

- Reinstall the blade holder (tightening torque 160 Nm). Carefully place the machine on the floor.

Replace the fastening screws when the blades are removed (tightening torque 140Nm).

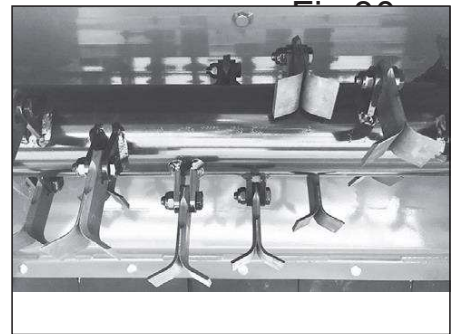

728 Replacing the rubber caterpillars

The rubber caterpillars are wear parts and their service life depends on the environment in which the machine is operated.

For the replacement of the caterpillars, lift the machine and place 4 supports under the mowing deck. For the removal of the automatic tensor, install a threaded rod (available in the electric cabinet) and a 13-wrench in between the crawlers. Screw the long bolts into the wheel support.

Fig 31

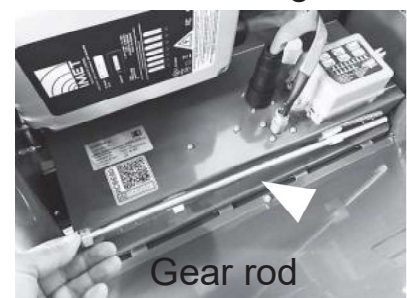

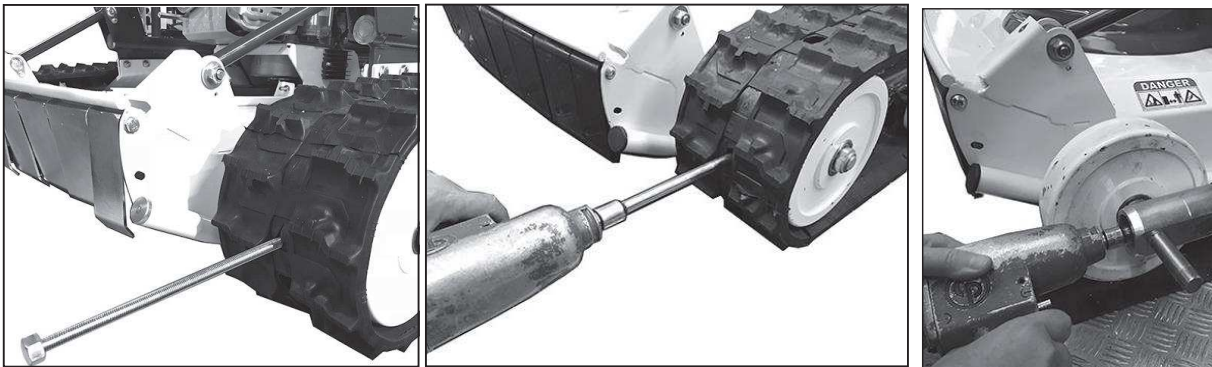

Remove the outer wheel as shown in the figure. The crawler belt can be removed Fig 32.

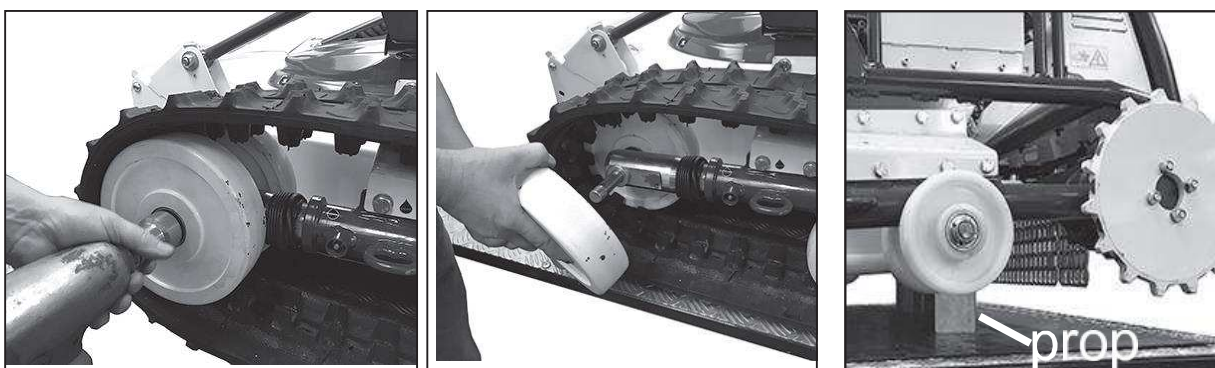

Fig 33



IMPORTANT

Use of the tensioner lock

The correct use of the belt tensioner is very important. The tensioner must be adjusted in accordance with the work conditions. An incorrect selection of the tensioner position may result in the machine stopping at the worksite.

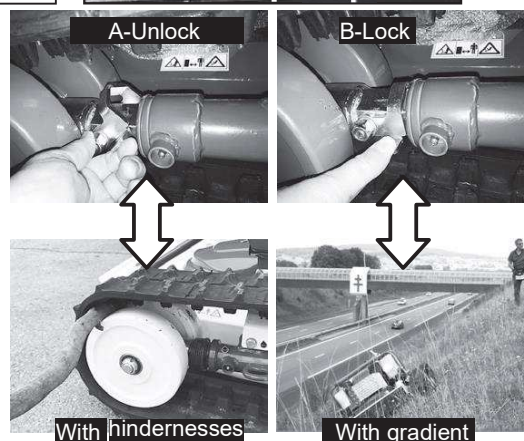

729 Battery and remote control

The radio transmitter is supplied with 2 Li-MH batteries. Although one battery is sufficient for one day, it is recommended to charge both batteries before starting work.

For charging the battery, a battery charging device is supplied with the radio control.

Technical data of the charging device

- Supply voltage 230V AC
- Required output 35mA AC/250mA DC (during charging)
- Charging current 650mA
- Battery Ni-MH 3.6V 1.7 A/h
- Max. charging time 3 hours
- Type of charging PVD
- Housing protection class IP30
- Operating temperature (charge) 0°C ÷ +35°C



Fig 34

7.3 Instructions for disposal



Li-NH battery

The symbol of a crossed-out disposal container on the device means that it must be handled separately from normal waste. The owner is liable for the transport of the old equipment to the specific collection sites for the recycling electric and electronic waste material. Separation of waste contributes to the protection of the environment and makes recycling easier.



Pb battery

Dispose of the battery correctly because the lead contained in a battery is a serious contaminator. Used batteries must be disposed of at the specific collection sites in accordance with the legal provisions.



Oil drainage

Ensure that waste oil that is seriously contaminated can leak. A few drops may contaminate high water volumes. Collect the waste oil in appropriate containers and dispose of it at the recycling service

WARRANTY**SECTION 8 - CLAIMS AND WARRANTY**

The basic principle of the warranty provisions is abiding by and observance of the corresponding operating manuals.

Never try to retrofit the mower without previous authorization, since this may be very dangerous. Damage or worn parts must be replaced by original parts from the manufacturer. Unauthorized parts may cause the mower to fail, result in accidents and make the manufacturer warranty void.

In case of doubt about causes or possible solutions for a specific problem, contact your authorized specialist dealer.

This is required during the warranty period because any repairs that are performed by unauthorized workshops make the warranty void.

Always ensure that the contractual dealer has all special tools, technical data and replacement parts available which are required for fixing the machine properly.

The warranty is only valid if the device is used correctly, such as defined in the first pages of this manual, and in accordance with the operating instructions and maintenance instructions contained therein. The warrantor

8.1 DEFINITION

Intends to guarantee to replace defective machine parts after a test for which the fault was determined is performed by our technical division. The transport costs are expressly excluded by the warranty and are borne by the customer. Any inconveniences caused by the negligence and incompetency as well as by external causes (atmospheric means, fire) are also excluded; last but not least the elements that are in contact with the ground (blades, knives, bumpers, tires). The guarantee is also void when accessories and spare parts are used on the machine which are not supplied or authorized by the manufacturer.

8.2 START OF WARRANTY: The warranty period starts on the date the vehicle is delivered by the first individual dealer or on the date of commissioning by an authorized dealer.

8.3 DURATION

The warranty period is:

-24 months for the private use of the machine;

-12 months for commercial, municipal or leased use.

For this period, the warranty terms according to section 8.1 are applicable.

8.4 MOTOR WARRANTY

The terms and conditions and provisions of the warranty are the provisions established by the manufacturer of the motor. All support within the scope of the warranty must be strictly performed in authorized service centers. Further details can be found in the motor manual supplied with the machine.

8.5 WARRANTY APPLICATION

Always indicate:

- 1- Machine type
- 2- Serial number of the machine
- 3- Working hours
- 4- Part designation and code number
- 5- Required quantity
- 6- Circumstances of the failure

We recommend indicating these data here for future communication:

XFLAIL

BARBIERI GROUP
MADE IN ITALY

BARBIERI Srl

BHV Barbieri Hybrid Vehicle

P.le D. Luigi Sturzo, 15

00144 Roma - Italy

Phone +39-0444-885-722

Fax: +39-0444-885-482

Parts code: OM - 6200 - 200 - V1 - D
Publishing date: 15 January 2020
Printed in Italy