

***MDB***



***USE AND  
MAINTENANCE  
MANUAL***

***LV 600 PRO***

***ENGLISH***

Translation from  
"Istruzioni originali"

ver. 00 07/2023



# MDB



[www.mdb srl.com](http://www.mdb srl.com)

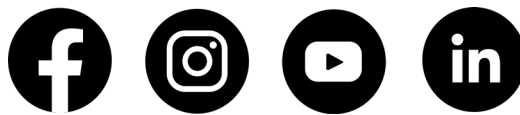

To be filled in with the actual machine data.

			
<b>MADE IN ITALY - <a href="http://www.mdb srl.com">www.mdb srl.com</a></b>			
C.da S. Onofrio, 6/A - 66034 Lanciano (CH) ITALY Tel. (+39) 0872 50221 - 508566 - Fax (+39) 0872 50231			
<input type="radio"/> <b>Designazione:</b> <input type="text"/>			
<b>Modello:</b>	<input type="text"/>	<b>Anno:</b>	<input type="text"/>
<b>Potenza:</b>	<input type="text"/>	<b>Matricola:</b>	<input type="text"/>
<b>Portata:</b>	<input type="text"/>	<b>Peso:</b>	<input type="text"/>
Conforme alle Direttive comunitarie CEE/2006/42/CE e successive implementazioni In conformity with ECC rules 2006/42/CE and subsequent implementation			

## WARNING

For the explanations of the fields in the machine plate, see the indications in chapter 3.

## INTRODUCTION

- › Before starting any operation on the machine and/or the packaging of the parts, read with attention the entire instruction manual.
- › The instruction manual contains important information for the safety of the persons who shall act on the machine and also for the machine itself.
- › It is the responsibility of the machine user Company to always ascertain that all the operators have fully understood the instructions for use.
- › Although the machine is equipped with active and passive safety devices, it is not possible to avoid all the risks caused by an incorrect use.
- › MDB shall not be held liable for any non-observance of the safety and prevention standards described in the various sections of this manual or for damages caused by improper use of the machine. Any modifications to the machine are to be authorised beforehand by MDB.
- › All operations on the machine (maintenance, repairs, cleaning) are to be carried out by appropriately trained personnel and following the indications contained in this manual.

**MDB reserves the right to make technical modifications to this manual and on the machine with no obligation of prior notification.**

**Requests for other copies of this manual are to be addressed to the MDB Customer Service Dept.**

**Reserved property; duplication is forbidden**

**This documentation or parts of the same are not to be reproduced, stored, transmitted, copied or translated into any language, common or computerised, in any form or by any means without explicit written authorisation of MDB.**

## WARNING

**MDB protects its rights regarding the drawings and the technical documentation in accordance with the law.**

**MDB supplies the guarantee regarding the contents of this publication, with the explicit prohibition to use this publication for other purposes, of any type, that do not concern the functioning of the machine to which it refers and for which this documentation has been drawn up.**

**The correctness of the information contained herein is guaranteed providing all the provisions contained in this documentation are scrupulously observed by the user.**





# TABLE OF CONTENTS

<b>1 SAFETY</b>	<b>1-1</b>
1.1 GENERIC SAFETY RULES.....	1-1
1.1.1 SAFETY PROCEDURES.....	1-1
1.1.2 EMERGENCY PRECAUTIONS.....	1-2
1.1.3 PREPARATION OF THE WORKING AREA.....	1-2
1.1.4 WARNING THAT MAINTENANCE IS IN PROGRESS.....	1-2
1.1.5 PRECAUTIONS AGAINST LIGHTNING.....	1-2
1.1.6 PARKING THE MACHINE IN SAFETY.....	1-2
1.1.7 SAFE HANDLING OF LIQUIDS AND PREVENTION OF FIRE.....	1-3
1.1.8 PRECAUTIONS AGAINST RISK OF BURNS.....	1-3
1.1.9 PRECAUTIONS AGAINST CONTACT WITH LIQUIDS AT HIGH PRESSURE.....	1-4
1.1.10 FIRE PREVENTION.....	1-4
1.1.11 PREVENTION OF POSSIBLE SHORT CIRCUITS OR ELECTRICAL FAILURES.....	1-4
1.1.12 PRECAUTIONS FOR THE USE OF INFLAMMABLE LIQUIDS.....	1-5
1.1.13 REMOVAL OF TRACES OF INFLAMMABLE MATERIALS.....	1-5
1.1.14 ABANDON OF THE MACHINE IN THE CASE OF FIRE.....	1-5
1.1.15 PRECAUTIONS AGAINST EXPOSURE TO EXHAUST GAS.....	1-6
1.1.16 PREVENTION OF BATTERY EXPLOSIONS.....	1-6
1.1.17 PRECAUTIONS FOR THE USE OF THE COOLANT LIQUID.....	1-7
1.1.18 SAFE HANDLING OF CHEMICAL PRODUCTS.....	1-7
1.1.19 CORRECT DISPOSAL OF WASTE.....	1-8
1.2 SAFETY SYMBOLS LEGEND.....	1-9
1.2.1 WARNING SYMBOLS.....	1-9
1.2.2 PROHIBITION SYMBOLS.....	1-10
1.2.3 OBLIGATION SYMBOLS.....	1-11
1.2.4 OTHER SYMBOLS.....	1-11
1.3 SIGNALLING BY GESTURES.....	1-12
<b>2 GENERAL INFORMATION</b>	<b>2-1</b>
2.1 MANUFACTURER'S IDENTITY DATA.....	2-1
2.1.1 TECHNICAL SERVICE.....	2-1
2.2 WARRANTY.....	2-3
2.3 PRESERVATION OF THE MANUAL.....	2-4
2.4 TO WHOM THE MANUAL IS ADDRESSED.....	2-4
2.5 RESEARCH CRITERIA AND CONSULTATION OF THE MANUAL.....	2-4
2.6 ENVIRONMENTAL REQUIREMENTS.....	2-4
<b>3 MACHINE DATA</b>	<b>3-1</b>
3.1 IDENTITY PLATE.....	3-1
3.2 DESCRIPTION.....	3-2



3.2.1	LIST OF GROUPS.....	3-3
3.3	TECHNICAL SPECIFICATIONS.....	3-4
3.3.1	DimensionS.....	3-4
3.3.2	WEIGHT.....	3-5
3.3.3	CAPACITY.....	3-5
3.3.4	OTHER TECHNICAL DATA.....	3-5
3.3.5	MOTOR DATA.....	3-5
3.4	WORKING AREA.....	3-6
3.4.1	POSITION OF OPERATOR.....	3-7
3.4.2	MACHINE DIRECTION ORIENTATION POINTS.....	3-9
3.5	RUNNING-IN.....	3-9
3.6	MACHINE CONFIGURATIONS.....	3-10
3.7	SAFETY PLATES.....	3-11
3.8	DISPOSITIVI DI SICUREZZA.....	3-12
3.9	PROFESSIONAL QUALIFICATIONS OF THE USERS.....	3-13
3.9.1	Operator.....	3-13
3.9.2	MAINTENANCE TECHNICIAN.....	3-14
3.10	PERMITTED USES.....	3-14
3.11	USES NOT PERMITTED.....	3-14
3.12	NOISE.....	3-14
3.13	PERSONAL PROTECTION EQUIPMENT.....	3-15
3.14	RADIO-CONTROL CASE, DOCUMENTATION AND EQUIPMENT.....	3-16
3.15	ATTACHMENTS.....	3-16
3.16	RESIDUAL RISKS.....	3-17
3.17	EMERGENCY DEVICES.....	3-18

## **4 UNPACKING, LIFTING AND TRANSPORT 4-1**

4.1	UNPACKING.....	4-2
4.2	LIFTING.....	4-4
4.2.1	LIFTING WITH CRANE, HOIST, BRIDGE CRANE.....	4-5
4.2.2	LIFTING WITH LIFT TRUCK.....	4-6
4.3	TRANSPORT.....	4-7

## **5 OPERATION AND USE 5-1**

5.1	CONTROL PANEL.....	5-1
5.1.1	Display.....	5-2
5.1.2	DISPLAY MENU.....	5-3
5.1.3	DESCRIPTION OF POSSIBLE WARNING/ERROR MESSAGES.....	5-7
5.1.4	DPF regeneration for KHOLER -KDI 1903 TCR Stage V engines.....	5-9
5.1.5	Alarms.....	5-17
5.2	RADIO CONTROL.....	5-26
5.2.1	Radio control description WITH DISPLAY.....	5-26
5.2.2	Radio control description WITHOUT DISPLAY.....	5-28
5.2.3	Remote control LED.....	5-30
5.3	ON-BOARD CONTROLS.....	5-31



5.4	PRE-START CONTROLS .....	5-32
5.4.1	<i>Filling up with fuel</i> .....	5-33
5.4.2	REFILLING ENGINE OIL .....	5-34
5.4.3	REFILLING COOLANT .....	5-34
5.4.4	<i>Rifornimento olio Idraulico</i> .....	5-34
5.4.5	<i>Battery connection/presence check</i> .....	5-34
5.5	START-UP .....	5-35
5.5.1	<i>Manual start</i> .....	5-35
5.5.2	<i>Starting with radio control</i> .....	5-36
5.6	USE .....	5-37
5.6.1	<i>Main commands</i> .....	5-37
5.6.2	SAFETY RULES FOR USE .....	5-43
5.6.3	<i>UsE</i> .....	5-43
5.7	PARKING .....	5-44
5.8	STOP .....	5-45
5.8.1	<i>Manual stop</i> .....	5-45
5.8.2	<i>Stop with radio control</i> .....	5-46
5.9	HYDRAULIC CONNECTION OF OPTIONAL TOOLS .....	5-47

## **8 MAINTENANCE**

**6-1**

8.1	PREPARING TO PERFORM MAINTENANCE .....	6-1
8.1.1	<i>Engine compartment bonnet</i> .....	6-2
8.2	EQUIPMENT PROVIDED .....	6-2
8.3	SCHEDULED MAINTENANCE TABLE .....	6-3
8.3.1	<i>Checklist</i> .....	6-5
8.4	ROUTINE MAINTENANCE .....	6-8
8.4.1	<i>General checks i</i> .....	6-8
8.4.2	<i>General machine cleaning</i> .....	6-8
8.4.3	<i>Radiator cleaning</i> .....	6-9
8.4.4	<i>Engine oil check</i> .....	6-10
8.4.5	REFILLING ENGINE OIL .....	6-10
8.4.6	<i>Changing engine oil and oil filter</i> .....	6-10
8.4.7	LEVEL CHECK, TOPPING UP COOLANT .....	6-11
8.4.8	HYDRAULIC OIL LEVEL CHECK, TOPPING UP AND REPLACEMENT .....	6-13
8.4.9	REPLACING AIR FILTER CARTRIDGE .....	6-15
8.4.10	<i>Air filter cleaning</i> .....	6-16
8.4.11	<i>Changing air filters</i> .....	6-16
8.4.12	<i>Hydraulic oil filter check</i> .....	6-17
8.4.13	<i>Replacing the hydraulic oil filter</i> .....	6-17
8.4.14	<i>Filter Separator Control</i> .....	6-18
8.4.15	<i>Filter separator cleaning</i> .....	6-18
8.4.16	<i>Filter separator replacement</i> .....	6-18
8.4.17	REPLACEMENT OF FUEL CARTRIDGE AND PREFILTER .....	6-19
8.4.18	C CHECK FILTER CARTRIDGE AND FUEL PREFILTER .....	6-20
8.4.19	POLY-V ALTERNATOR BELT CHECK .....	6-21



8.4.20 CHECK AND ADJUSTMENT OF STANDARD ALTERNATOR BELT TENSION .....	6-22
8.4.21 RUBBER HOSE INSPECTION .....	6-24
8.4.22 OVERHEAD OIL DIPSTICK .....	6-25
8.4.23 OIL LEVEL CONTROL (STANDARD ROD) .....	6-25
8.4.24 Particulate filter cleaning .....	6-26
8.4.25 Particle filter replacement .....	6-27
8.4.26 Checking and tensioning tracks .....	6-28
8.4.27 Periodic lubrication .....	6-29
8.4.28 Control of clamping elements .....	6-30
8.4.29 Control of working elements .....	6-30
8.4.30 Refrigeration system control .....	6-30
8.4.31 Hydraulic system check .....	6-30
8.4.32 Electrical system check .....	6-30
8.5 EXTRAORDINARY MAINTENANCE .....	6-35
8.5.1 Track replacement .....	6-35
8.6 REGISTER OF CONTROLS AND PERIODIC INSPECTIONS .....	6-37

## 7 TROUBLESHOOTING

**7-1**

7.1 GUIDE TO SOLVE PROBLEMS .....	7-1
7.1.1 RADIO CONTROL .....	7-1
7.1.2 Motor .....	7-2
7.1.3 TRACKS .....	7-3
7.1.4 BUZZER .....	7-3
7.1.5 INDICATION WARNING LIGHTS .....	7-3
7.1.6 MOVEMENT DEVICES .....	7-4

## 8 DISMANTLING

**8-1**

8.1 TEMPORARY PUTTING OUT OF SERVICE .....	8-1
8.2 PERMANENT PUTTING OUT OF SERVICE- DISMANTLING .....	8-1



# 1 SAFETY

## 1.1 GENERIC SAFETY RULES

### 1.1.1 SAFETY PROCEDURES

- › Carefully read the information regarding safety contained in this manual and attain to the safety indications on the machine.
- › The safety indications are to be affixed, undergo periodical maintenance (cleaning) and, if damaged, replaced.
- › The machine is only to be used by authorised, qualified technicians who have been appropriately trained.
- › Acquire the necessary preparation and skills, with the correct procedures for machine use and maintenance.
- › The machine is to be always kept in optimal operating condition and is to be used with modes and purposes in consistency with the relevant technical specifications
- › Modification to components or replacement of these with components that are not originals, or any other type of modification not authorised in writing by the Manufacturer, jeopardises the safety and functioning, shortening the working life of the machine and annuls the warranty.
- › The Manufacturer shall not be held liable in the case of:
  - › Improper machine use.
  - › Modification of machine components not authorised in writing by the manufacturer.
  - › Personal injuries, machine failures and /or damage to materials and/or third parties, whether direct, connected, or consequential.
  - › Damages deriving from use of tools and/or components or optional accessories not authorised in writing by the manufacturer.
- › Use of the machine and related equipment in complete safety requires maximum concentration of the operator.
- › Do not use headsets to listen to music or radio while using the machine.

## WARNING

For further details, see the **GENERAL SALES CONDITIONS** on the site ([URL landing page general sales conditions](#)).



## CAUTION

The purpose of the information regarding safety contained in this chapter is to illustrate the most important safety procedures to be applied during use and activation of the machine.

If in doubt, or for further information regarding the safety procedures, contact the supervisor in charge and/or the authorised dealer, before using the machine or performing maintenance activities.



### 1.1.2 EMERGENCY PRECAUTIONS

- › In the case of fire or an accident, it is necessary to be prepared.
- › Establish a general emergency procedure, to be applied in the case of fire and/or accidents.
- › Always have on hand a first aid kit and an extinguisher.
  - › For correct use of the extinguisher, carefully read the information printed on the label applied.
  - › Inspect and carry out periodical maintenance on the extinguisher, following the frequencies indicated in the manual supplied with it, to ensure the perfect efficiency and correct functioning if needed.



## CAUTION

**Know your position and check it has a sufficient telephonic coverage, to be able to communicate in the case of need.**

**Always have a mobile phone with the emergency numbers to be able to contact doctors, ambulance service, hospital and fire brigade.**

### 1.1.3 PREPARATION OF THE WORKING AREA

- › Survey the working area before starting the activities.
- › Keep people at a distance and remove any objects that are in the range of action and movement of the machine.
- › Do not allow persons or vehicles to enter or transit in the working area.
- › Make sure that the surface of the working area is sufficiently solid to sustain the weight of the machine.

### 1.1.4 WARNING THAT MAINTENANCE IS IN PROGRESS

- › The ignition key is to be removed from the control panel and kept by the maintenance technician.
- › Before starting operations on the machine, place the "Maintenance in progress" card.
- › Never start the machine when there is the "Maintenance in progress" card.

### 1.1.5 PRECAUTIONS AGAINST LIGHTNING

- › If lightning strikes the machine, or a point near it, check the perfect integrity of all the machine components and devices, especially the machine safety devices.
- › If any type of fault is found, do not activate the machine and contact the service department for the repair.

### 1.1.6 PARKING THE MACHINE IN SAFETY

- › When the machine is not in use it has to be parked on a solid flat surface.
- › After parking, switch off the machine as indicated in Chapter 5.



### 1.1.7 SAFE HANDLING OF LIQUIDS AND PREVENTION OF FIRE

**DANGER**

Handle the fuel with extreme care because it is very inflammable. Combustion can cause explosions and fires with the risk of serious injuries.



All types of fuel and most lubricants are inflammable.

- › Refuelling is to be carried out in the open.
- › Always switch off the motor before refuelling.
- › Never refuel the machine near naked flames or sparks.
- › Keep the inflammable liquids away from potential sources of fire.
- › Do not burn or perforate the containers.

### 1.1.8 PRECAUTIONS AGAINST RISK OF BURNS

- › When using the machine, the motor cooling liquid is hot and under pressure.
- › During machine use, the motor oil and the hydraulic oil reach high temperatures.
- › The piping of the cooling plant contains hot water or steam, which, in the case of accidental contact with the skin can cause burns.
- › The hydraulic oil plant piping contains hot oil, that in the case of accidental contact with the skin can cause burns.

**CAUTION**

To avoid burns caused by hot liquids, only carry out operations on the machine after allowing all the hot parts of the machine to cool.



The operator is to wear the following personal protection equipment:

- › Safety shoes
- › Protective gloves
- › Protective clothing
- › Protective goggles



### 1.1.9 PRECAUTIONS AGAINST CONTACT WITH LIQUIDS AT HIGH PRESSURE

- › Liquids under pressure can penetrate in the skin and in the eyes, causing serious injuries.
- › To avoid this risk, discharge the residual pressure.



#### CAUTION



**The operator is to wear the following personal protection equipment:**

- › Safety shoes
- › Protective gloves
- › Protective clothing
- › Protective goggles

- › Use a strip of cardboard to check for any leaks.
- › In the case of accidental contact with liquid under pressure, contact a doctor immediately.

### 1.1.10 FIRE PREVENTION



#### DANGER



**Any fuel, hydraulic oil and/or lubricant leaks can cause fire, with consequent risk of serious injuries.**

- › Make sure there are no straps missing or slackened, bent flexible hoses, rubbing between rigid and /or flexible pipes.
- › If necessary, tighten, repair or replace the radiator, the straps, piping, flexible hoses that are slackened or damaged.
- › Do not bend or knock high pressure piping.
- › Never install bent or damaged piping, flexible hoses.

### 1.1.11 PREVENTION OF POSSIBLE SHORT CIRCUITS OR ELECTRICAL FAILURES

- › Clean and tighten all the electrical connections.
- › Check that the cables and electric wires are not slackened, bent, hardened, worn or damaged.



#### CAUTION



**Short circuits can cause fires.**

**Do not use the machine if there are loosened, bent and/or damaged cables or wires.**



### 1.1.12 PRECAUTIONS FOR THE USE OF INFLAMMABLE LIQUIDS



**DANGER**



Traces of fuel, hydraulic oil and/or lubricant can cause fire, with consequent risk of serious injuries.

- › Prevent the risk of fire by checking and cleaning the machine every day, immediately removing traces or accumulation of inflammable liquid or material.
- › Do not keep inflammable liquids near naked flames.
- › Do not burn or destroy pressurised containers.
- › Do not wear clothes impregnated with oil, these materials can catch fire very easily.
- › Do not wrap material that easily absorb oil around components with high temperature.

### 1.1.13 REMOVAL OF TRACES OF INFLAMMABLE MATERIALS



**DANGER**



Traces of fuel, hydraulic oil and /or lubricant, dirt, grease, scrap, dust residue, other inflammable materials can cause fire with consequent risk of serious injuries.

- › Prevent fire risks by checking and cleaning the machine every day, immediately removing oil or accumulation of inflammable material.
- › Check and clean parts subject to high temperatures.
- › Do not wrap parts subject to high temperatures with oil absorbents.
- › Keep inflammable materials away from naked flames.
- › Do not burn or crush a container under pressure or that is sealed.
- › Check and clean the machine every day, immediately removing any accumulation of inflammable materials.

### 1.1.14 ABANDON OF THE MACHINE IN THE CASE OF FIRE

In the case of fire during machine use, leave the machine working zone and switch off the machine as indicated in chapter 5.



### 1.1.15 PRECAUTIONS AGAINST EXPOSURE TO EXHAUST GAS

#### CAUTION



**Motor exhaust gases are toxic.**

- › If it is necessary to operate the machine inside buildings, ensure that the room ventilation is adequate

### 1.1.16 PREVENTION OF BATTERY EXPLOSIONS

#### DANGER



**The liquid contained in the battery can explode.**

- › Do not create sparks and do not light flames near the battery.
- › Never check the battery charge placing a metal object between the poles. Use a volt meter.
- › If a terminal slackens it can produce sparks. Firmly tighten all the terminals.
- › Connect the terminals to the correct electric poles. Ignoring this recommendation can cause damage to electrical parts or fires.
- › Always wear personal protection equipment when checking the relative density of the electrolyte.

#### CAUTION



**The operator is to wear the following personal protection equipment:**

- › Safety shoes
- › Protective gloves
- › Protective clothing
- › Protective goggles

- › The battery electrolyte is toxic. If there is a battery outflow, the electrolyte contained in it could penetrate in the eyes.
- › In the case of contact with the eyes, wash with abundant water for some minutes. Contact a doctor immediately.



### 1.1.17 PRECAUTIONS FOR THE USE OF THE COOLANT LIQUID



#### CAUTION



Contact of the eyes or the skin with the coolant liquid can cause serious injuries, burns and permanent damage.

When using coolant liquid, always read the warnings on the container.

- › Use a recovery and recycling system to avoid introduction of the coolant liquid into the atmosphere.
- › Do not expose the skin to direct contact with the coolant liquid.
- › Always wear personal protection equipment when checking the relative density of the electrolyte.



#### CAUTION



The operator is to wear the following personal protection equipment:

- › Safety shoes
- › Protective gloves
- › Protective clothing
- › Protective goggles

### 1.1.18 SAFE HANDLING OF CHEMICAL PRODUCTS



#### DANGER

Direct exposure to harmful chemical products can cause serious injuries.

- › The potentially harmful chemical products used on the machine include:
  - › Lubricants
  - › Electrolyte
  - › Coolant liquids
- › The safety data card gives specific details regarding chemical products: physical hazards for health, safety procedures and response techniques to emergencies.
- › Consult the safety data card before starting operations that require the use of chemical products.
- › Follow the procedures indicated and wear the recommended personal protection equipment.



#### DANGER



The operator is to wear the following personal protection equipment:

- › Safety shoes
- › Protective gloves
- › Protective clothing
- › Protective goggles



### 1.1.19 CORRECT DISPOSAL OF WASTE



## CAUTION



**Incorrect disposal of waste can cause environmental and ecological damage.**

**Contact the nearest environmental protection or recycling centre for information regarding the correct disposal procedures for harmful waste, such as oil, fuel, coolant liquid, filters, electrolyte liquid.**

- › The potentially toxic waste used on the machine includes: oil, fuel, coolant liquid, filters, electrolyte liquid.
- › When purging liquids, use sealed containers with a higher capacity as to the volume of purged liquid.
- › Do not dispose of the waste on the land, in sewers or in rivers.



## **1.2 SAFETY SYMBOLS LEGEND**

The following safety signs may be applied on the machine.

### **1.2.1 WARNING SYMBOLS**



**GENERIC HAZARD**



**HOT SURFACES HAZARD**



**HANGING LOADS HAZARD**



**EXPLOSIVE MATERIAL HAZARD**



**LIFT TRUCKS HAZARD**



**TOXIC SUBSTANCES HAZARD**



**CRUSHING HAZARD**



**INFLAMMABLE MATERIAL HAZARD**



**CORROSIVE SUBSTANCES HAZARD**



**ELECTROCUTION HAZARD**



**ENTRAPMENT IN MOVING PARTS HAZARD**



**CRUSHING OF THE HANDS HAZARD**



**CUTTING OF HANDS HAZARD**



**UPPER LIMBS ENTRAPMENT/SHEARING HAZARD**

### 1.2.2 PROHIBITION SYMBOLS



**GENERIC PROHIBITION**



**DO NOT LUBRICATE OR CLEAN WHEN IN MOTION**



**DO NOT REMOVE PROTECTIONS**



**DO NOT USE NAKED FLAMES**



**DO NOT INSERT THE HANDS**



**DO NOT CLIMB**



### 1.2.3 OBLIGATION SYMBOLS

It is obligatory to:



**READ THE INSTRUCTIONS BEFORE OPERATING ON THE MACHINE**



**WEAR PROIECTIVE GLOVES**



**WEAR PROTECTIVE GOGGLES**



**WEAR PROTECTIVE CLOTHING**



**WEAR SAFETY SHOES**



**WEAR HEARING PROTECTORS**



**WEAR THE PROTECTIVE SHIELD**



**WEAR A HARD HAT**



**WEAR A MASK**



**LIFT THE MACHINE IN THE SIGNED POINTS**

### 1.2.4 OTHER SYMBOLS



**DISPOSAL IN COMPLIANCE WITH STANDARDS IN FORCE**



**1.3 SIGNALLING BY GESTURES**

When it is necessary to position loads and the operator has a limited field of vision, assign a person (signaller) to signal the manoeuvres to be carried out using the specific signs established by the standards.

When extra instructions are necessary that differ from those defined by the system of signalling by gestures, these are to be agreed together by the signaller and the operator before starting to handle the load and/or the machine.



**CAUTION**

**No movement or operation is to be carried out before the signals have been clearly understood by the signaller and the operator.**

**Signals are to be executed by one person only.**

**The operator is to check that the signaller is always within sight and follow all the gestures.**

<p><b>LIFT THE LOAD VERTICALLY</b> With the forearm positioned vertically and the index finger pointing upward, rotate the hand in small circles.</p>	
<p><b>LOWER THE LOAD VERTICALLY</b> With the arm stretched and index finger pointing downward, rotate the hand in small circles.</p>	
<p><b>MOVE THE LOAD AWAY HORIZONTALLY</b> With the arm stretched forward and the hand in vertical position facing toward the load to be moved away, move the hand toward the direction of the movement to be made.</p>	



<p><b>APPROACH THE LOAD HORIZONTALLY</b>                  With the arm stretched forward and the hand in vertical position facing toward the signaller, move the hand toward the direction of the movement to be made.</p>	
<p><b>TRANSLATE STEERING TO THE RIGHT</b>                  Raise the forearm of the side of the steering with the first closed. Vertically rotate the other fist indicating the direction of rotation of the wheel/track.</p>	
<p><b>TRANSLATE STEERING TO THE LEFT</b>                  Raise the forearm of the internal side of the steering with the fist closed. Vertically rotate the other fist indicating the direction of rotation of the wheels/tracks.</p>	
<p><b>TRANSLATE STRAIGHT FORWARD</b>                  Rotate the fists vertically indicating the direction of rotation of the wheels/tracks.</p>	
<p><b>TRANSLATE STRAIGHT BACKWARD</b>                  Rotate the fists vertically indicating the direction of rotation of the wheels/tracks.</p>	



**DISTANCE TO BE COVERED**

With the hands raised and turned inward, move the hands sideways indicating the distance to be covered.



**MOVE SLOWLY**

Position one hand stopped in front of the other hand that indicates the movement to be made (The figure illustrates the instructions to lift slowly).

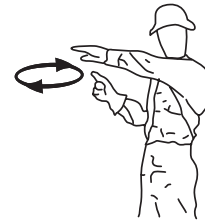

**STOP**

With the arms stretched laterally, open the hand facing downward and move the arm forward and backward.

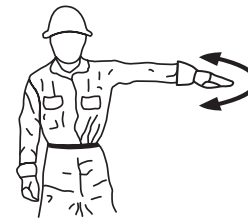

**EMERGENCY STOP**

With both arms stretched horizontally, open the hands facing downward and move both arms forward and backward.

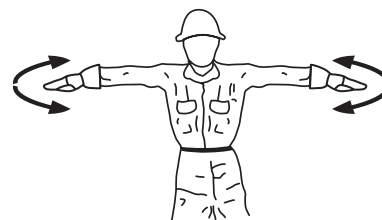

**STOP THE MOTOR**

Pass the thumb or the index finger on the throat.





## 2 GENERAL INFORMATION

### 2.1 MANUFACTURER'S IDENTITY DATA

Name	MDB S.r.l.
Work site	Contrada, Via Cupone, 13, 66022 Fossacesia CH
Telephone	+39 0872.50221
Fax	+39 0872.50231
web site	www.mdb srl.com
E-Mail	info@mdb srl.com
VAT code	01960690699

#### 2.1.1 TECHNICAL SERVICE

Technical service will be provided by the Manufacturer by access to the MDB gateway (<https://cloud.interactivespares.com/mdb>) entering the personal access data.

The customer, scrupulously following the indications provided by the manufacturer, is to fill in the request for service, inserting the following data:

- › Machine model
- › Machine year of manufacture
- › Machine identity serial number
- › Hours of operation
- › Type of problem found

After entering the data, the customer is to provide the Manufacturer with all the necessary information to assess the case, therefore including any documentation photo/video, upon request of the manufacturer.

Subsequently, the Manufacturer will make a technical analysis (remote) of the problems highlighted and, if possible, provide the necessary service.

From the technical analysis it is to result that the problems that have occurred have not been caused by incorrect use and/or maintenance or by improper use or by normal wear, according to the instructions contained in the "Use and Maintenance" manual supplied to the Customer by the Manufacturer.

### WARNING

For further details see the **GENERAL SALES CONDITIONS** on the site (**URL landing page general sales conditions**).



### ORIGINAL SPARE PARTS

Modification of components or replacement with components that are not originals, or any other modification not authorised in writing by the Manufacturer, will jeopardise safety and functioning, shortening the working life of the machine and annuls the warranty.

The request for original MDB spare parts is to take place via the MDB gateway (<https://cloud.interactivespares.com/mdb>) where the Customer will enter the personal data.

The customer, scrupulously following the indications provided by the manufacturer, is to fill in the request for spare parts, inserting the following data:

- › Machine model
- › Machine year of manufacture
- › Machine identity serial number
- › Hours of operation
- › Code of spare part required
- › Serial number of the component to be analysed (where present)

## WARNING

For further details see the **GENERAL SALES CONDITIONS** on the site (URL landing page general sales conditions).



## 2.2 WARRANTY

Unless otherwise agreed in writing, the Manufacturer guarantees its products are without flaws including manufacturing defects, flaws in material used, for a period of 12 (twelve) months, as from the date of the registration of the MDB machine data (attaining to the serial number on the identity plate) to be executed within and not later than the essential term indicated in the general Sales conditions, under penalty of forfeiture.

This registration is obligatory via access to the gateway of MDB on the website <https://cloud.interactivespares.com/mdb>. Inserting the data required in the warranty activation module and consenting to the treatment of personal sensitive data

Any intervention that alters the configuration or functioning of the machine is to be carried out or authorised in writing by MDB.

The Manufacturer shall not be held liable for consequences that derive from use of spare parts that are not originals or interventions carried out by technicians of the Customer and/or by technicians not authorised by the Manufacturer and/or for which supervision of the Manufacturer is necessary and/or for which there is no written authorisation.

Since improper use of the Products (machine and spare parts) is forbidden, the warranty only covers the products used with the methods and purposes in consistency with the relevant technical specifications in accordance with the instructions of the manufacturer.

The Manufacturer shall not be held liable for any damages to third parties, direct and/or indirect, caused to persons or objects deriving from use of the machine or by machine stop, claims, or other direct causes consequent to or connected to use of the machine.

For the warranty coverage of components not manufactured by MDB, the terms and modalities provided by the supplier shall be valid.

Furthermore, the warranty is excluded in the following cases:

- › Bad management by the Dealer/Customer, the personnel of the customer or third parties.
- › Failure caused by negligence, improper use or fraud by the Dealer/Customer, the personnel of the customer or third parties.
- › Non-fulfilment of maintenance activities required by the Manufacturer and contained in this "Use and Maintenance" manual.
- › Wear of consumable materials (for example, tracks, tyres, oil, filters, rubber stoppers, etc) due to use.
- › Defects caused by any other cause ascribable to the Dealer/Customer, the personnel of the customer or third parties.
- › Alternation or replacement of product parts not authorised by the Manufacturer.

### WARNING

**During the warranty period, any service and/or extraordinary maintenance operations are not the task of the operator or the maintenance technician, but are reserved to the skilled technicians of MDB and/or technicians indicated by MDB.**

### WARNING

**For further details see the GENERAL SALES CONDITIONS on the site (URL landing page general sales conditions).**



### 2.3 PRESERVATION OF THE MANUAL

The manual and related attachments:

- › Are an integrating part of the machine and must always accompany it.
- › Are always to be kept where they are easily accessible and protected against environmental conditions that could damage the integrity and duration (see chapter 3).
- › Are to be available for rapid consultation at any time by the operators.

### 2.4 TO WHOM THE MANUAL IS ADDRESSED

The manual is divided for the persons assigned to the machine as follows:

- › Operator: in charge of the running and use of the machine.
- › Maintenance technician: to carry out routine maintenance on the machine.

## WARNING

**The term “operator” is generically used to identify a person who has to act on the machine: operator, maintenance technician, etc.**

For further information regarding to whom the manual is addressed, see chapter 3.

### 2.5 RESEARCH CRITERIA AND CONSULTATION OF THE MANUAL

The information and instructions are gathered and organised in chapters and paragraphs and can be traced by consulting the index. The basic information for the health and safety of the operators/maintenance technicians are preceded by warning signs that are to be read with care.

The safety instructions are classified as follows, according to the severity of the risk:



## DANGER

**Indicates cases where, if the safety instructions are not observed, SERIOUS injuries could occur to the persons or damage to the machine.**



## CAUTION

**Indicates cases where, if the safety instructions are not observed MODEST injuries could occur to the persons or damage to the machine.**



## CAUTION

**Indicates cases where, if the safety instructions are not observed MINOR injuries could occur to the persons or damage to the machine.**

## WARNING

**This indication highlights a note in the manual which is important both for machine use and maintenance or general information.**

### 2.6 ENVIRONMENTAL REQUIREMENTS

The machine:

- › Can function in a ventilated environment.
- › Can function at temperatures ranging between -30°C and +40°C.

The machine:

- › Is NOT to function in potentially explosive atmospheres.
- › Is NOT to function in environments where there is risk of fire.



### 3 MACHINE DATA

#### 3.1 IDENTITY PLATE

The plate is applied on the machine in the zone indicated in the figure.



The plate contains the following data:

Name	Type of machine
Model	Machine model
Power	Motor power (kW)
Capacity	Maximum capacity of the machine (Kg)
Year	Year of machine manufacture
Serial number	Machine identification serial number
Weight	Weight of machine (Kg)

## WARNING

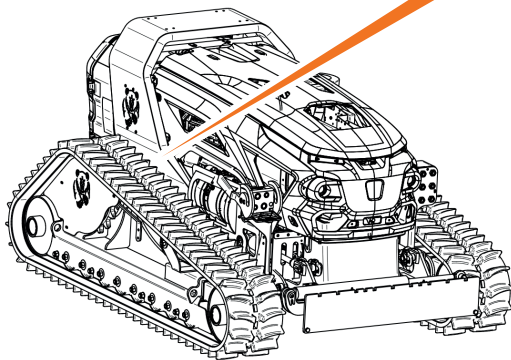
For the actual data of the machine concerned, see the values indicated on the second cover of this manual.



**MADE IN ITALY - [www.mdb srl.com](http://www.mdb srl.com)**

Calle S. Ondofio, 6/A - 65034 Lerciano (CI) ITALY Tel. (+39) 0872 50221 - 500566 - Fax (+39) 0872 50221

Designazione:

Modello:	Anno:
Potenza:	Matricola:
Portata:	Peso:

Conforme alle Direttive comunitarie CEE/2006/42/CE e successive implementazioni  
In conformity with FCC rules 2006/42/CE and subsequent implementation



## WARNING

The EC marking is only applied in the European Community environment or in cases where it is foreseen.



### 3.2 DESCRIPTION

The machine has been designed for the installation of fixtures and has the characteristics indicated in paragraph "3.10 Permitted uses" and paragraph "3.3 Technical specifications".

The machine control operations are by radio-control, which permits the operator to control it while remaining at a distance.

With the radio-control the operator can work calmly in safety, observing the indications regarding the position of the operator, as indicated in paragraph "3.4.1. Position of the operator".

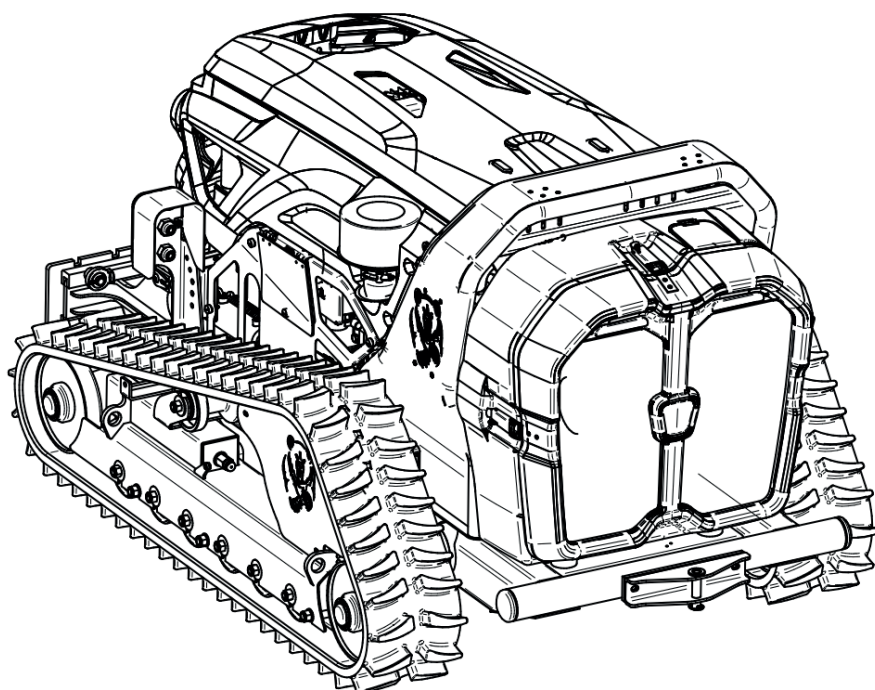
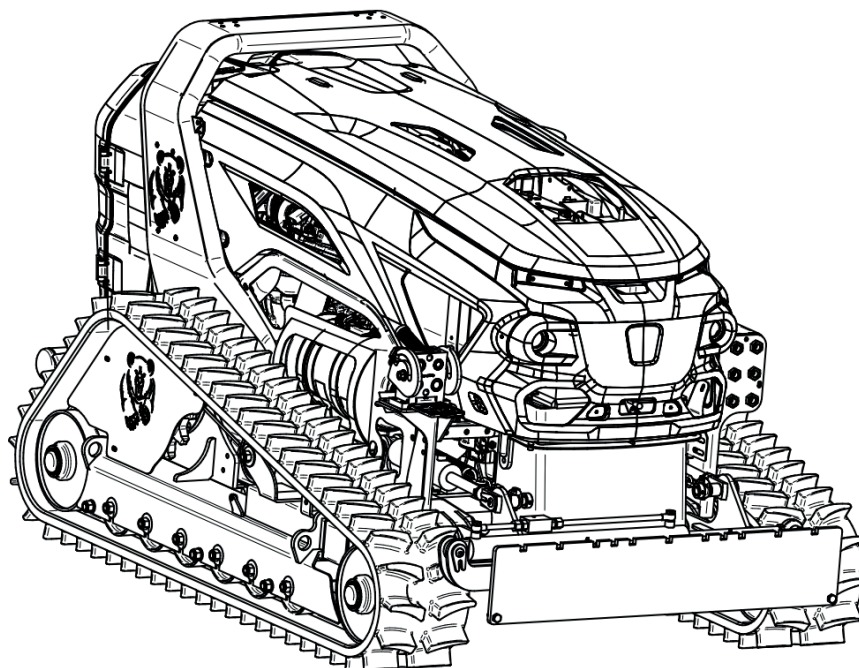



### 3.2.1 LIST OF GROUPS

- 1 Cowling
- 2 Motor
- 3 Water-oil radiator
- 4 Hydraulic oil tank
- 5 Fuel tank
- 6 Pumps group
- 7 Tracks
- 8 Tracks hydraulic motors
- 9 Tracks widening/narrowing cylinder
- 10 Manual distributor
- 11 Control panel
- 12 Radio-control without display
- 13 Radio-control with display
- 14 Control unit (receiver)
- 15 Fixture hydraulic connection valve
- 16 Fixture holder plate
- 17 Fixture holder plate lateral translation cylinder
- 18 Fixture holder plate vertical translation cylinder
- 19 Ignition key selector
- 20 "Battery isolator" key

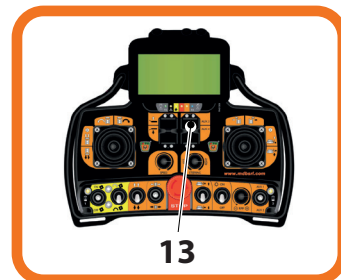
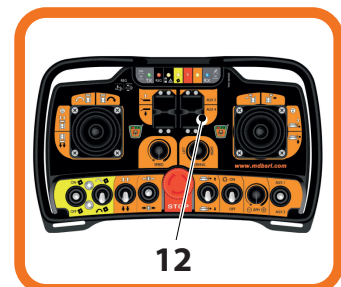
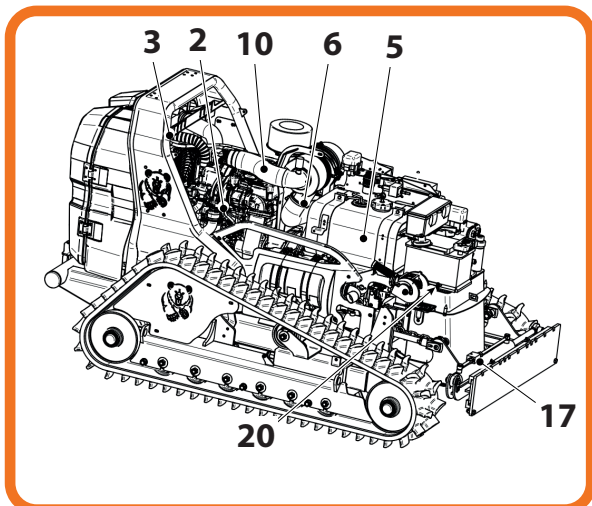
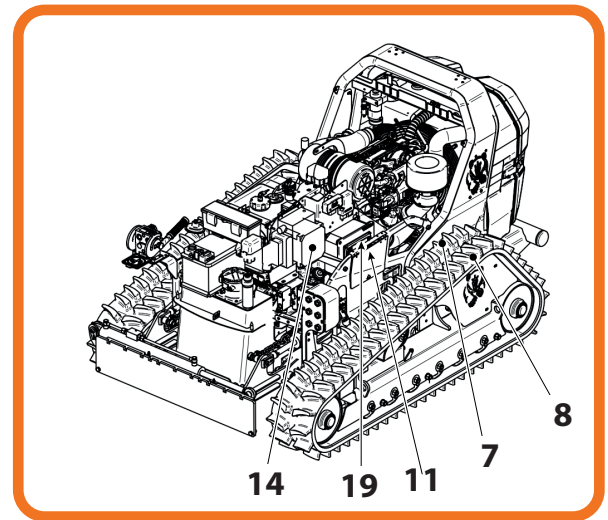
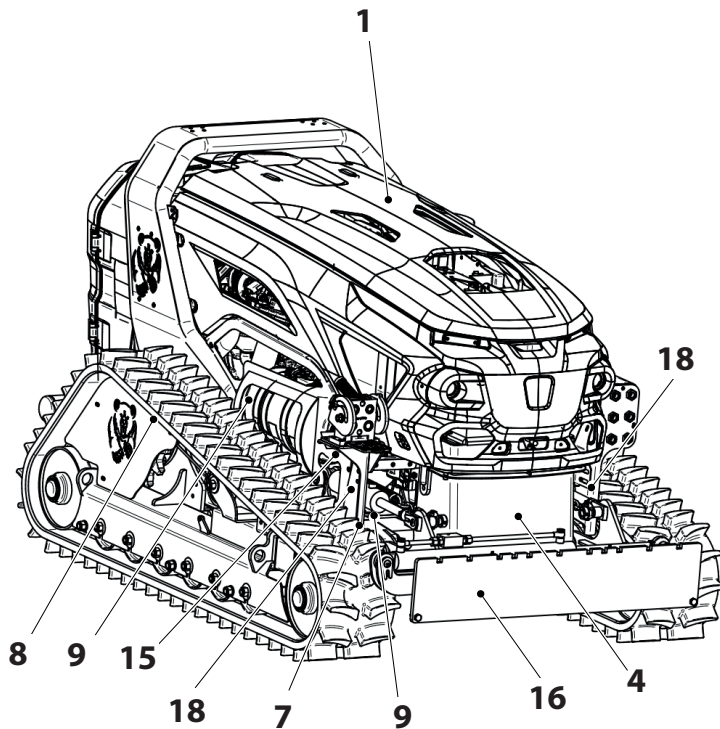



### 3.3 TECHNICAL SPECIFICATIONS

#### 3.3.1 DIMENSIONS

The machine dimensions are indicated in the figure.

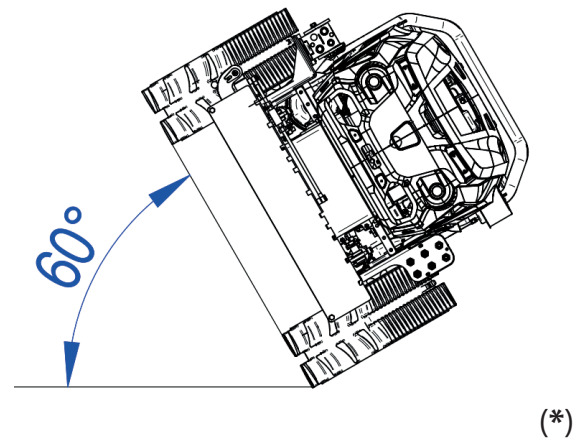
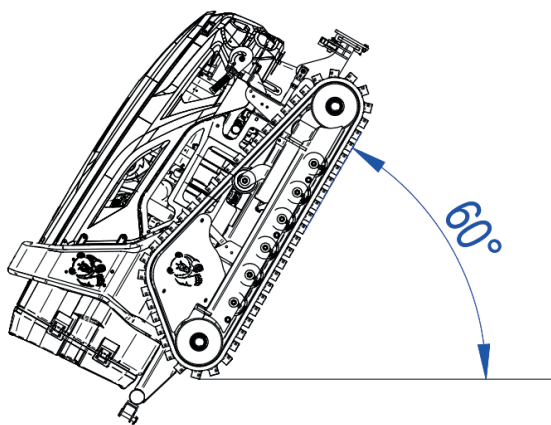
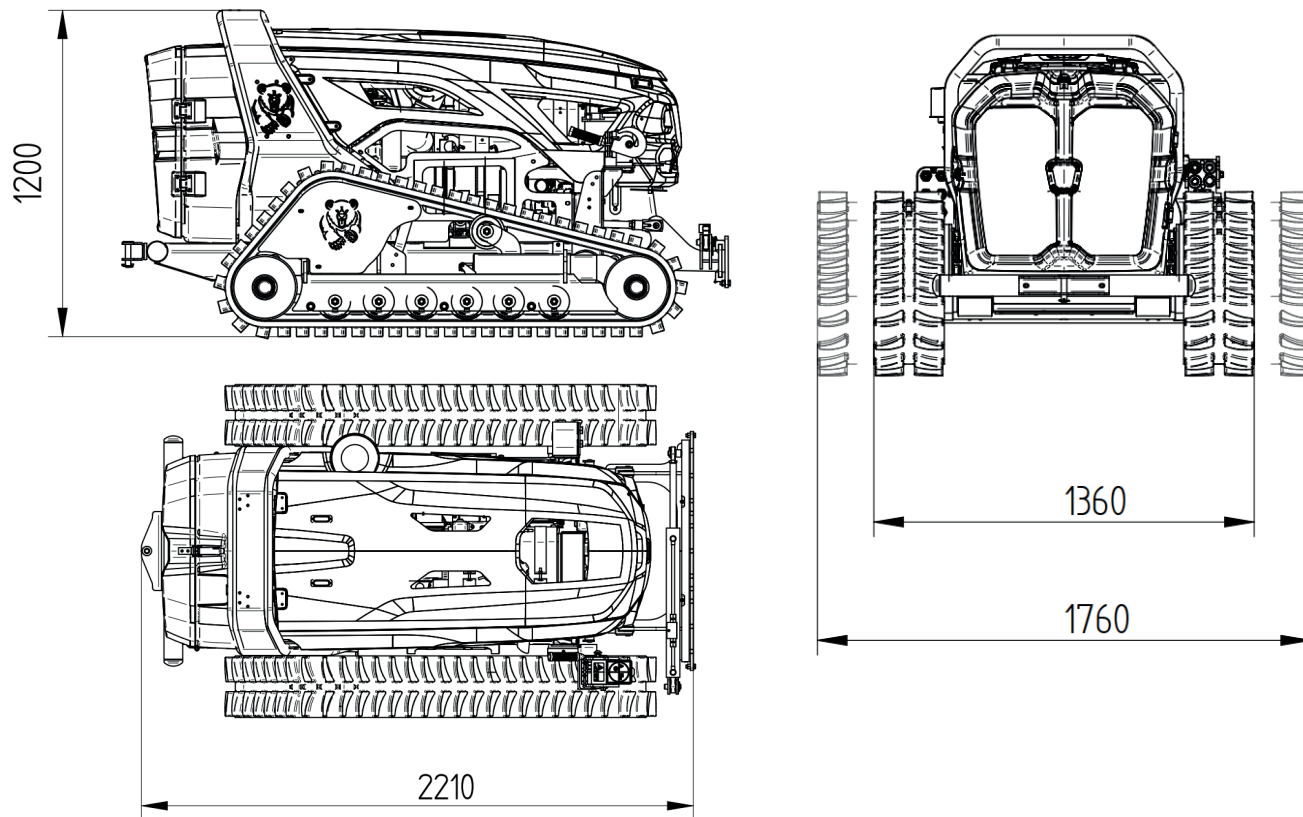



### 3.3.2 WEIGHT

For this information see the value indicated on the second cover of this manual.

### 3.3.3 CAPACITY

For this information see the value indicated on the second cover of this manual.

### 3.3.4 OTHER TECHNICAL DATA

Maximum speed	<b>9 Km/h</b>
Rpm	<b>For this information see attachment B</b>
Fuel tank capacity	<b>34 l</b>
Hydraulic oil tank capacity	<b>32 l</b>
Coolant tank capacity	<b>10 l</b>
Motor oil tank capacity	<b>For this information see attachment B</b>
Type of fuel	<b>For this information see attachment B</b>
Type of hydraulic oil	<b>PANOLIN HLP SYNTH</b>
Type of coolant	<b>ENI ANTIFREEZE SPEZIAL FS KG 200</b>
Type of motor oil	<b>10W40</b>
Type of grease for periodical lubrication	<b>PRESSOL NLG1 2</b>
Battery	<b>12 Volt - 74 Ah</b>

### 3.3.5 MOTOR DATA

For this information see attachment B.



### 3.4 WORKING AREA

The working area **A** where the machine operates (where the fixture is installed or not), has to be segregated by specific signalling devices before starting to work..



#### CAUTION

During machine use, working area **A** is prohibited for all persons.

The confirmation, dimensions and danger of the working area depends on the type of fixture that installs the machine.

#### WARNING

In particular, the working zone of the part in front of the fixture **V** changes considerably according to the type of fixture installed.

Therefore, for more, detailed information regarding the working area, see the manual of the fixture which is to be installed on the machine.

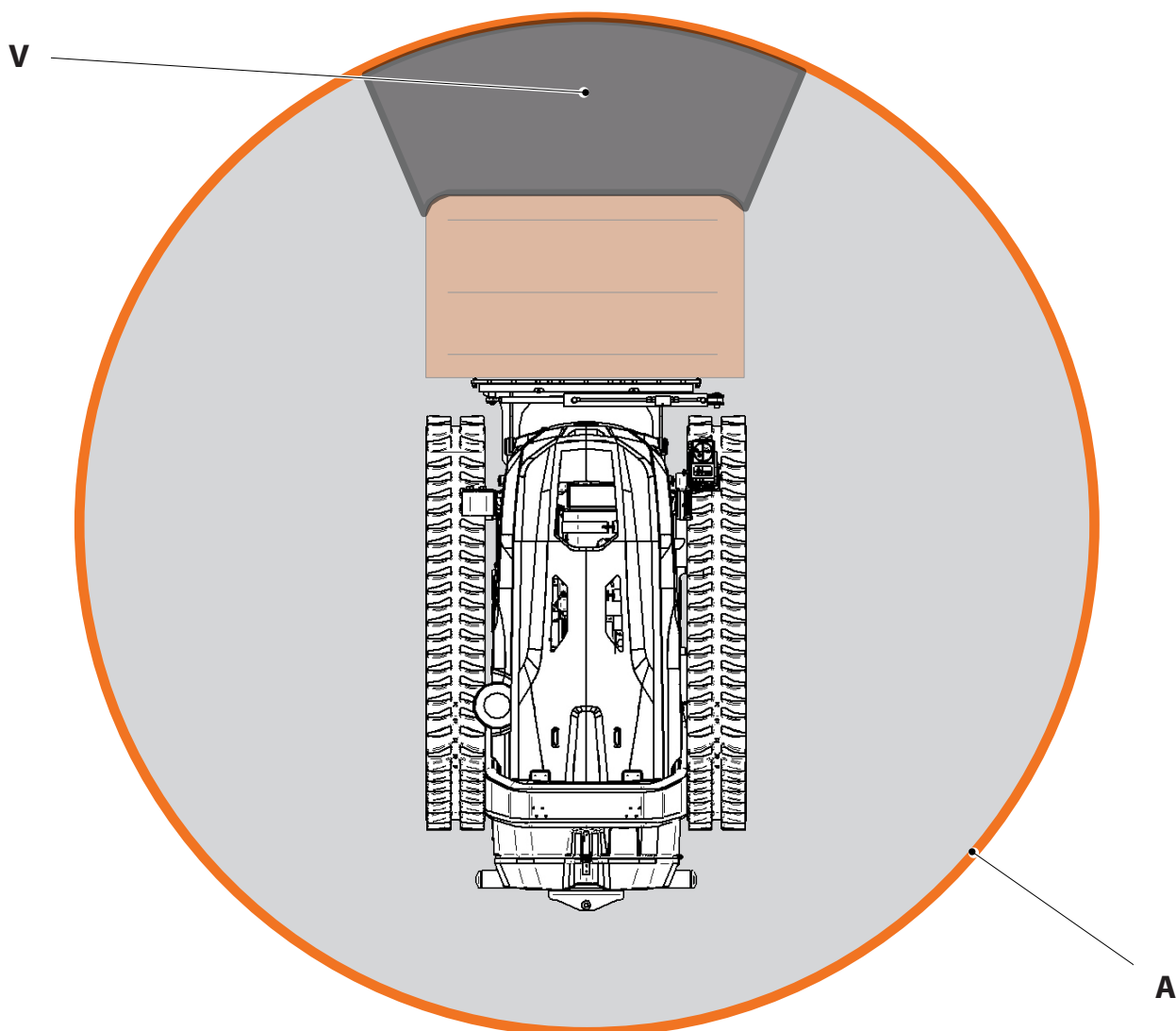



### 3.4.1 POSITION OF OPERATOR

The operator activates the machine through the radio-control and it is obligatory to remain at a minimum distance **X** of **3 metres**, positioning as shown in the figure.

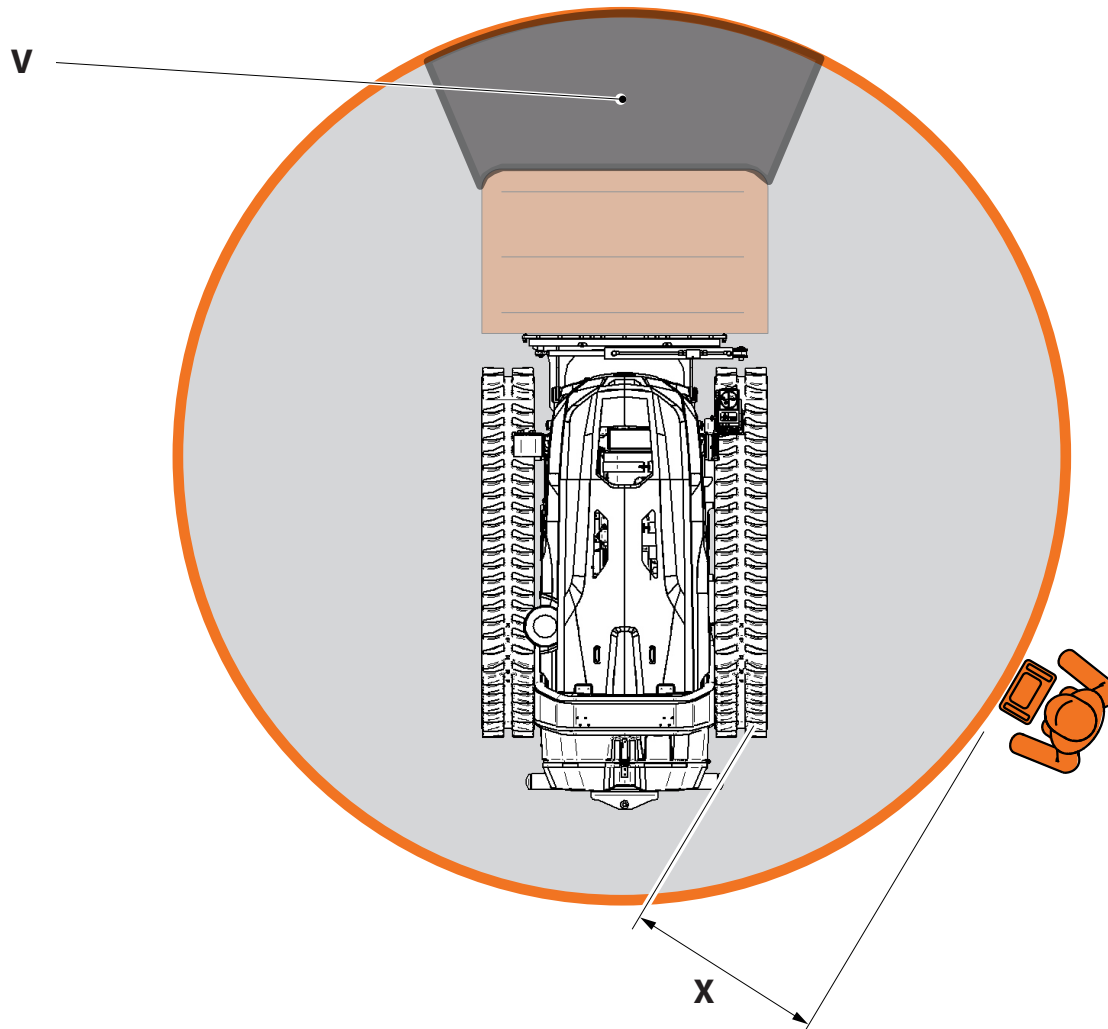

The zone in front of the fixture installed on the machine (V) may be the source of various hazards.



**DANGER**

Therefore, for more detailed information regarding the zone (V), see the manual of the fixture which is to be installed on the machine.

Wear the prescribed personal protection equipment, as indicated in paragraph "3.13 Personal Protective Equipment".

**DANGER**

If the machine is used on sloped ground, always remain in a position upstream to it, as shown in the figure.

Always maintain a minimum distance  $X$  of 3 metres from the machine, as shown in the figure.

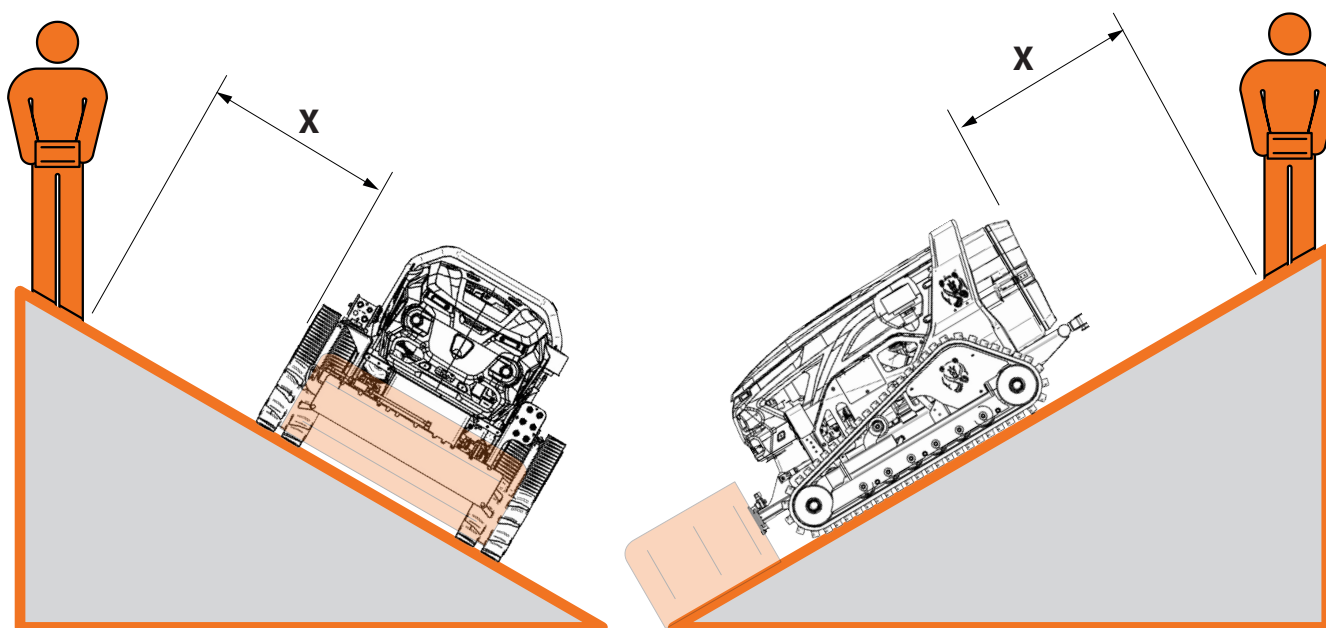
**DANGER**

Use of the machine on sloped ground is only possible in work only configuration, as indicated in paragraph "3.6 Machine configurations" and paragraph "3.3 Technical specifications".

Never exceed the maximum working angle, as indicated in paragraph "3.3 Technical specifications".



### 3.4.2 MACHINE DIRECTION ORIENTATION POINTS

In this manual, the terms **Forward/Front (1)**, **Backward/Rear (2)**, **Left (3)** and **Right (4)** refer to the directions of the machine translation, as indicated in the figure.

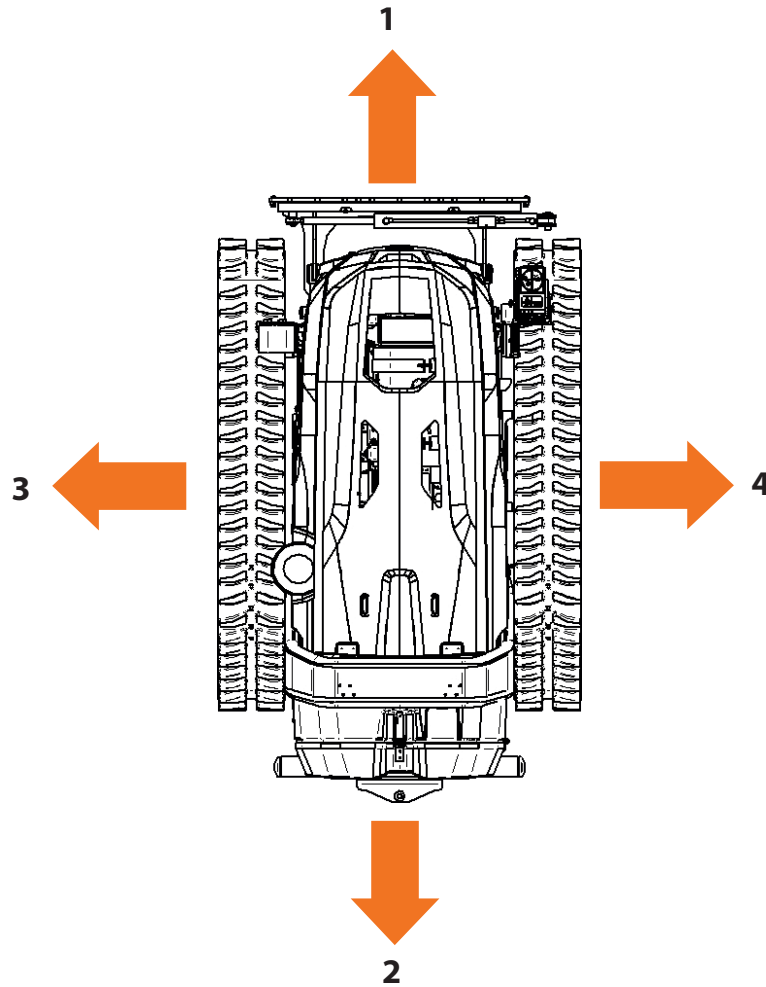

### 3.5 RUNNING-IN

#### WARNING

Each machine is scrupulously adjusted and tested before delivery.

A new machine is to be used with caution for the first hours of operation.

Every new machine has to be used with attention, especially regarding the following:

- › After ignition, allow the motor to run at minimum for a few minutes so as to permit a gradual warm-up (see chapter 5).
- › Do not allow the machine to function at the limit of the allowed loads or at high speed (see chapter 5).

#### WARNING

For all other information see attachment B.



### 3.6 MACHINE CONFIGURATIONS

The machine is used in the following configurations:

- 1 Work and movement configuration
- 2 Work only configuration

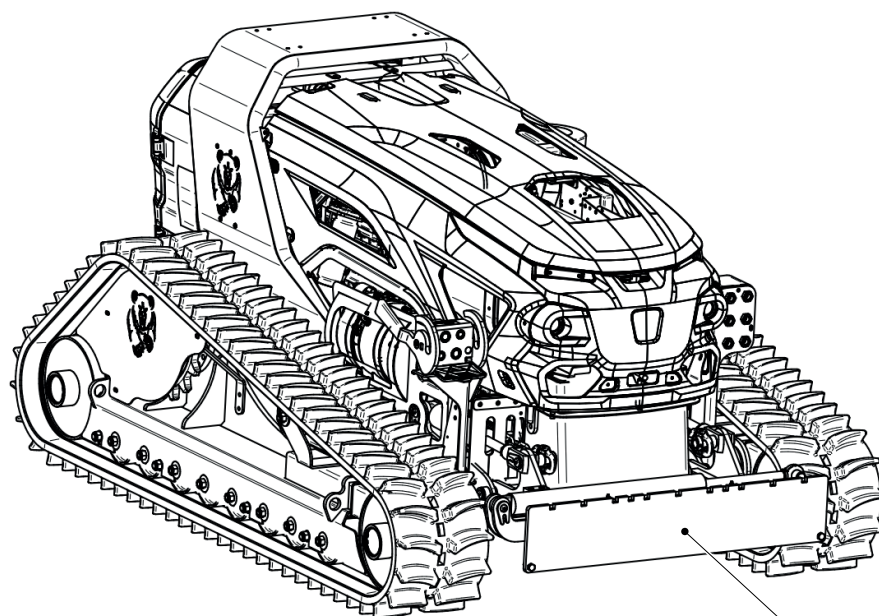

1

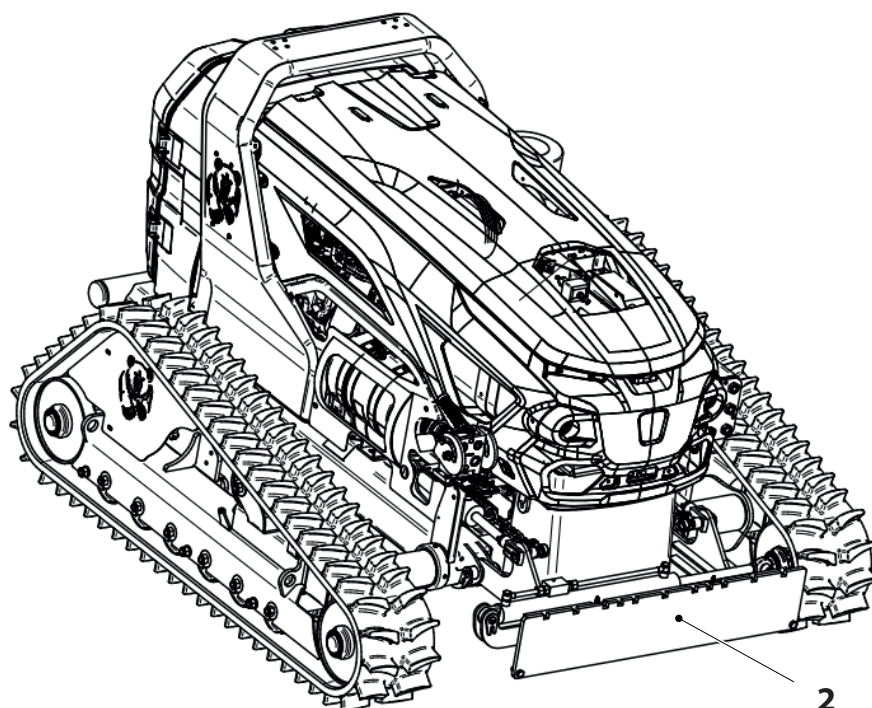

2



3.7 SAFETY PLATES

1	2	3	4				
5	6	7					
8						9	

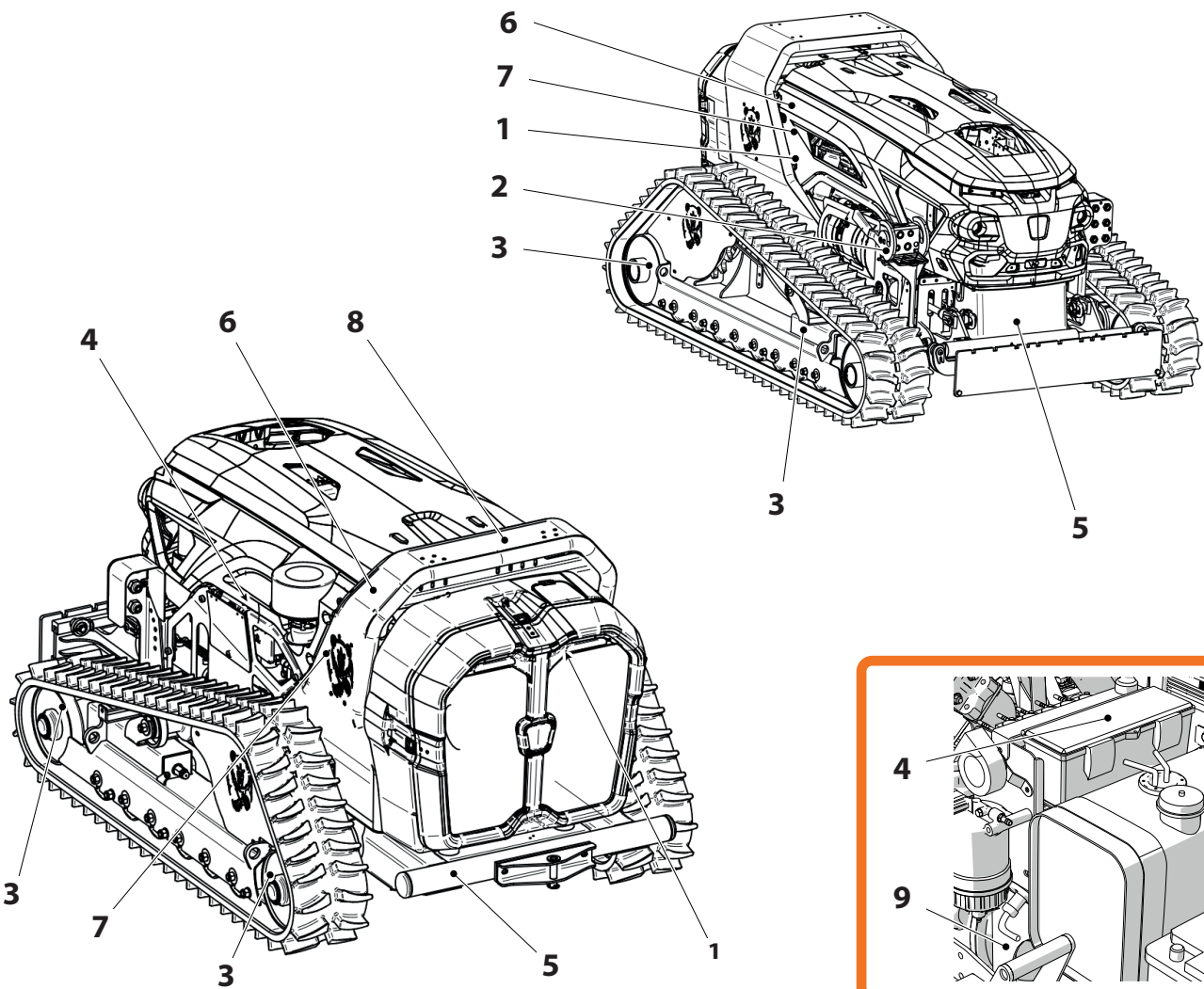



**3.8 DISPOSITIVI DI SICUREZZA**

- |   |  |    |                                    |
|---|--|----|------------------------------------|
| 1 | Control panel emergency button                           | 9  | Ignition key selector              |
| 2 | Radio-control emergency button                           | 10 | "Battery isolator" key             |
| 3 | Fixture-holder plate lowering lock and control valve     | 11 | Warning buzzer                     |
| 4 | Tracks motor brakes release solenoid valve               | 12 | Red lights (fixed)                 |
| 5 | Radiator fan control solenoid valve                      | 13 | White lights (fixed)               |
| 6 | Tracks widening/narrowing solenoid valve                 | 14 | Yellow lights (on-off)             |
| 7 | Fixture-holder plate vertical translation solenoid valve | 15 | Fixture hydraulic connection valve |
| 8 | Safety gas spring to maintain cowl position              |    |                                    |

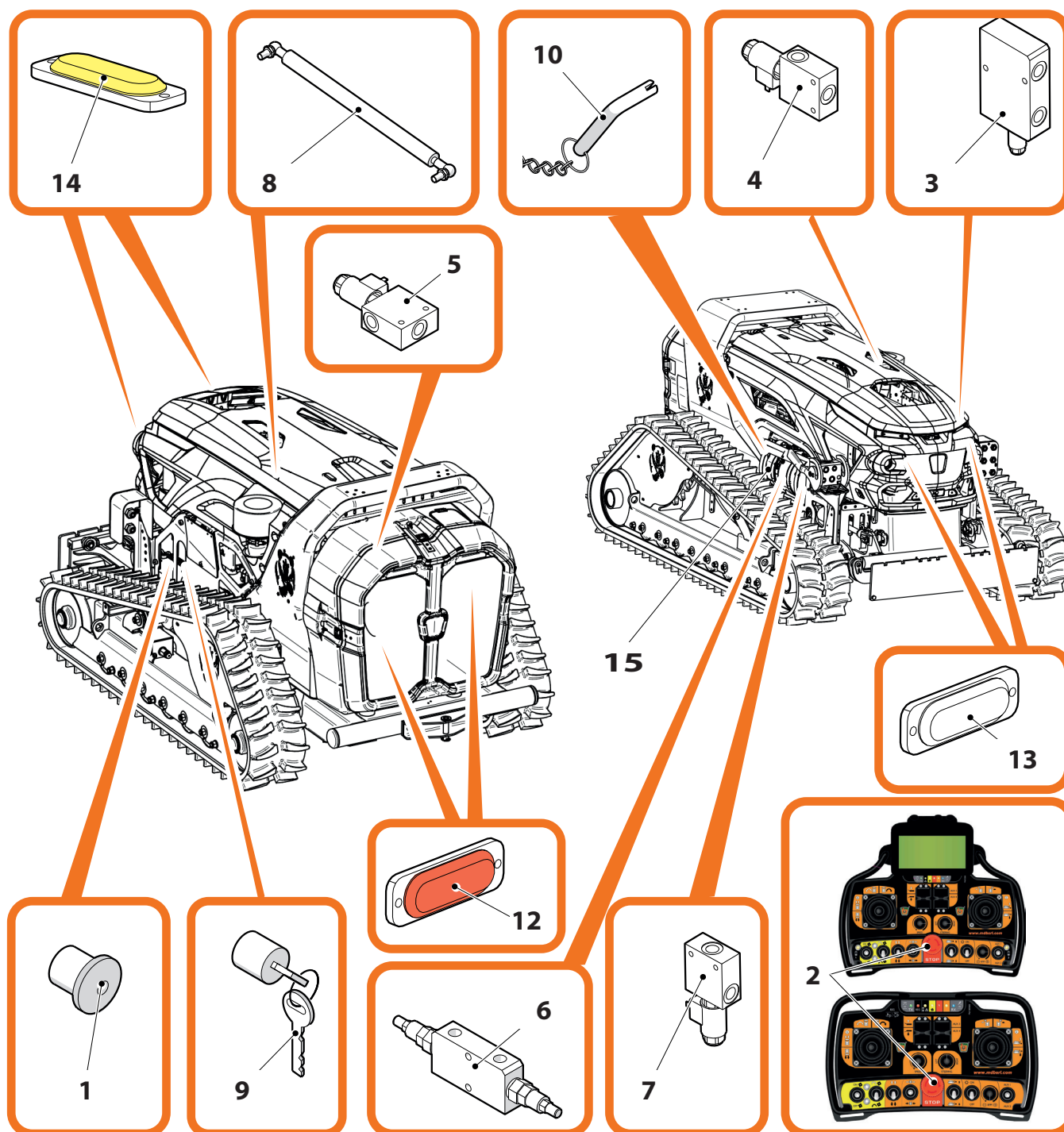



### 3.9 PROFESSIONAL QUALIFICATIONS OF THE USERS

The machine has been designed for professional use.

It is the responsibility of the end customer to ascertain that the persons assigned to the various tasks:

- › Read and understand this manual.
- › Receive the appropriate instruction and training to be able to carry out their tasks in safety.
- › Receive the specific training for correct use of the machine.
- › Use all the accident-prevention devices necessary for their safety, as specified by the laws in force regarding health and safety in the workplace.
- › Receive specific training to cope with any emergencies caused by accidents to the operators.

#### 3.9.1 OPERATOR

This type of machine can only be used by a skilled person (defined as operator) who has been instructed regarding the limits of use and the residual risks.

For the specifications for running, observe the national provisions of the country where the machine is used.



**DANGER**

**The use of drugs, alcohol or medicines that influence reflexes impair the ability to use the machine!**

**Persons under the effects of these substances are not authorised to carry out any job and are not to use the machine.**

The operator is to have:

- › Knowledge of the machine technology and specific experience in running the same.
- › General basic culture and basic technical knowledge sufficient to read and understand the contents of the manual, including the correct interpretation of the drawings.
- › Knowledge of the accident-prevention standards in force in the country where the machine is used:
  - › General (hygiene and safety in the workplace, accident prevention when working).
  - › Specific (for the type of machine).

#### TASKS OF THE OPERATOR

**WARNING**

**The operator is in charge of the machine during the working hours. The operator shall not allow unauthorised persons to act on the machine.**

The operator can only use the controls and tools mounted on the control panel and on the machine radio control.

The operator work position is indicated in paragraph "3.4.1 Position of operator".



### 3.9.2 MAINTENANCE TECHNICIAN

The maintenance technician is to have:

- › The specific technical and specialistic knowledge (mechanical, electrical, pneumatic, etc) necessary to carry out the relevant operations indicated in this instructions manual in safety, using appropriate tools or devices.
- › General basic culture and basic technical knowledge sufficient to read and understand the contents of the manual, including the correct interpretation of the drawings.
- › Knowledge of the accident-prevention standards in force in the country where the machine is used:
  - › General (hygiene and safety in the workplace, accident prevention when working).
  - › Specific (for the type of machine).

### TASKS OF THE MAINTENANCE TECHNICIAN

The maintenance technician can carry out the routine maintenance operations indicated in this manual, limited according to the mechanical, electrical, pneumatic skills.

### 3.10 PERMITTED USES

The machine has been designed for the installation of fixtures that perform many different operations.

The machine is only to be used in a ventilated environment.

## WARNING

**For further information see the manual of the fixture installed on the machine.**

### 3.11 USES NOT PERMITTED

No other use is foreseen (other than that specified in the previous paragraphs), unless specifically authorised by MDB.

MDB shall not be held liable for malfunctioning or damage to persons or objects caused by a use that differs from those indicated in this manual.

### 3.12 NOISE

Considering that the machine is designed to function in a ventilated environment, the noise has been measured as prescribed by directive 2000/14/CE regarding environmental acoustic emissions of machines and fixtures designed to function in the open.

The standard used to calculate the level of the acoustic power is UNI EN ISO 3744-2010, Standard UNI EN ISO 3744-2010 specifies the method to measure the sound pressure levels on a measuring surface containing the source, so as to calculate the acoustic power level emitted by the noise source.

Surface noise pressure level: **81,75 dB(A)**

Acoustic power level: **101 dB(A)**



## CAUTION



**The operator must wear the personal protection equipment specified (Acoustic protection) in accordance with the laws in force in the country where the machine is used.**



### 3.13 PERSONAL PROTECTION EQUIPMENT

## WARNING

The employer has the obligation to provide the personal protection equipment and inform the personnel regarding correct use and maintenance.

During all machine use and maintenance operations the operator and/or the maintenance technician is to use the following personal protection devices.



**PROTECTIVE GLOVES**



**PROTECTIVE SHIELD**



**PROTECTIVE CLOTHING**



**SAFETY SHOES**



**ACOUSTIC PROTECTION**



**PROTECTIVE HARD HAT**

## WARNING

Do not wear loose clothing, jewellery or other items that could become entangled in machine components during use and maintenance.



### 3.14 RADIO-CONTROL CASE, DOCUMENTATION AND EQUIPMENT

The machine technical documentation, relevant attachments and specific equipment supplied are packed in a specific case, which also houses the radio-control.

Other devices (for example radio-control battery charger and radio control spare battery) are placed in the box on the machine **1**.

## WARNING

To access the box on the machine, open the cowling as indicated in chapter 6.

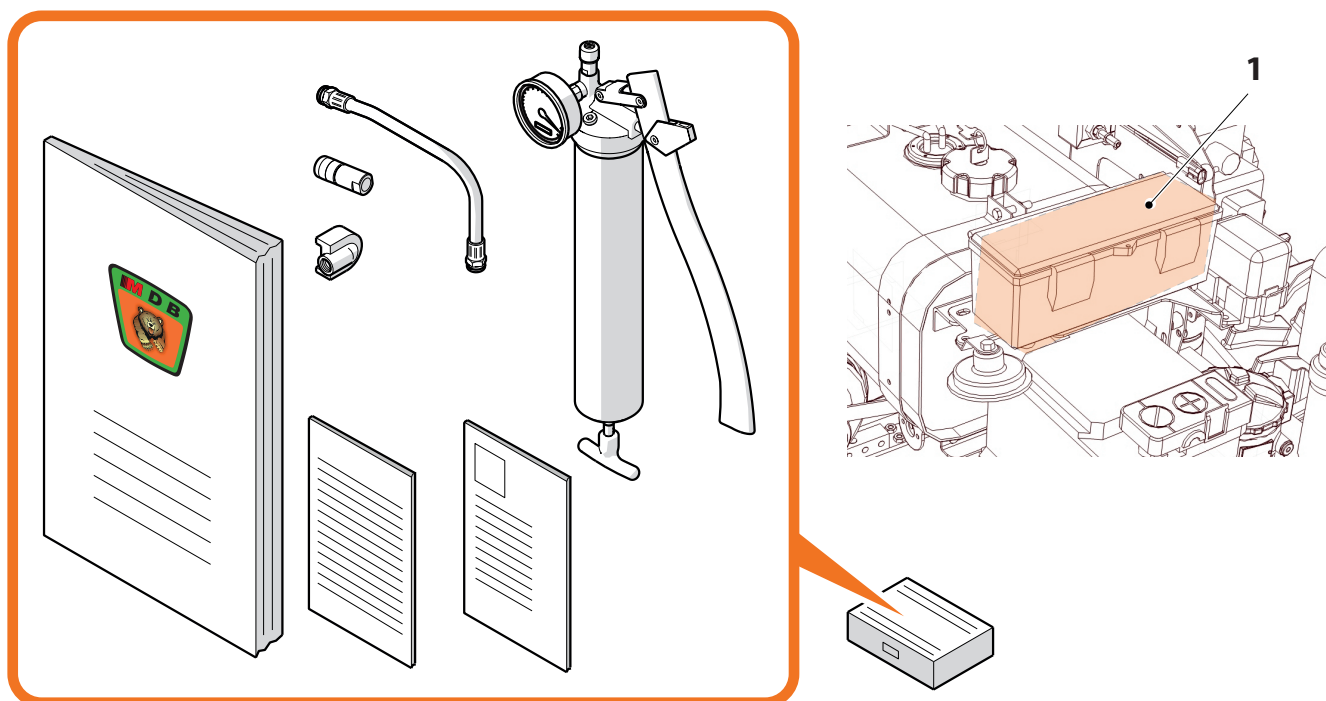

### 3.15 ATTACHMENTS

The following documents complete this instruction manual:

Attachment A – Declaration of conformity

Attachment B – Motor Use and Maintenance manual (and related technical sheet)

Attachment C – Radio control Use and Maintenance manual

Attachment D – Catalogue of machine spare parts

Attachment E – Use and Maintenance manual of fixtures (if present)



### 3.16 RESIDUAL RISKS



#### CAUTION

Pay attention to the machine range of action.

Avoid abrupt movements (acceleration, deceleration or steering).

Do not use in bad weather conditions.

Do not remove machine plates and labels.

It is obligation of the user to restore and keep clean the seals, plate and labels that have become illegible.



#### CAUTION

Do not use for towing operations.

During manoeuvres, keep at a distance from other obstacles.

Never leave the machine with motor running.

Act on the motors taking the appropriate precautions.

Do not lift persons.

Do not carry out any inspection, repair or maintenance operation on parts in motion.

Disconnect the battery cable before acting on the electrical plant.

During operation, the motor, like the components of the hydraulic plant can reach temperatures that could cause slight burns. Wait until cooled or apply appropriate precautions (gripping tools, gloves, etc) before taking action.

All fuels, many lubricants and some coolants are inflammable. Check the inflammability and toxicity before use. Follow the instructions of the supplier, especially regarding storage, disposal, emergency procedures.



#### DANGER

Keep inflammable fluids away from any contact with fire.

Do not burn or perforate pressurised containers.

Do not keep rags soaked in inflammable material, they could catch fire and/or burn spontaneously.

Handle fuel with care: it is highly inflammable. Fuel, if catches fire, can cause an explosion or a fire causing serious injuries or death.

Do not fill up while smoking or near sparks and fire.



Always stop the motor before filling.



**DANGER**

Fill the fuel tank in the open.

Scrupulously observe the maximum working slope permitted, as indicated in paragraph "3.3 Technical specifications".

### 3.17 EMERGENCY DEVICES

Hook **1** is an emergency device which is only to be used in the following situations listed below:

- › Machine breakdown.
- › Motor fault with impossibility to move the machine.

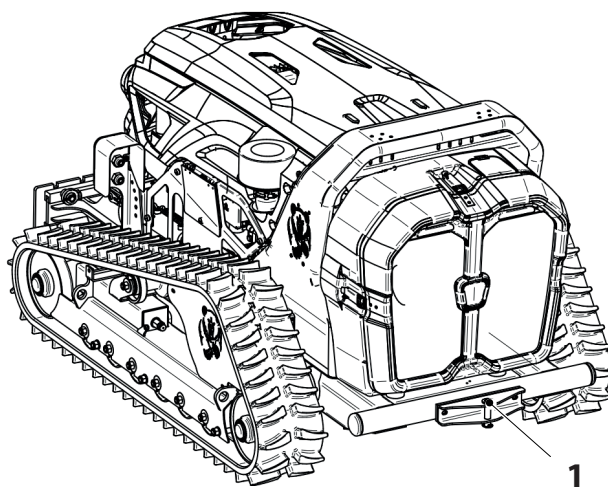

**CAUTION**

It is strictly forbidden to use the hook to tow trailers and /or trolleys.



## **4 UNPACKING, LIFTING AND TRANSPORT**

The unpacking, lifting and transport operations are only to be carried out by specialised operators, authorised for this type of handling.

No persons are to remain near hanging loads and/or within the range of action of the lifting equipment during the unpacking, lifting and transport of the load.



### **CAUTION**

Manual handling of the loads is to be carried out by persons trained in the correct methods for lifting, and following the safety provisions specified by the laws in force in the country of machine use.

MDB shall not be held liable for damage to objects and persons that are a consequence of the user's non - observance of the safety standards in force, regarding unpacking, lifting and transport of the load.



## 4.1 UNPACKING

### WARNING

The packaging, upon arrival in the works of the user, is to be handled with utmost care and moved, both externally and internally by equipment having an appropriate payload, in conformity with the indications on the packaging and/or in the accompanying documents of the package.



### CAUTION

The operator is to wear the following personal protection equipment:



- › Safety shoes
- › Protective gloves
- › Hard hat
- › Protective clothing
- › Protective goggles

The machine is shipped packed, as follows:

- › Machine secured to a pallet **1** with specific straps **2**.
- › Machine wrapped in protective material **3** against minor accidental bumps.
- › Machine further enclosed in transparent film to protect against dust, humidity and water.

### WARNING

Inside the packaging, there is a special case supplied that contains the radio-control, the machine technical documentation, the relevant attachments and the specific equipment part of the supply.

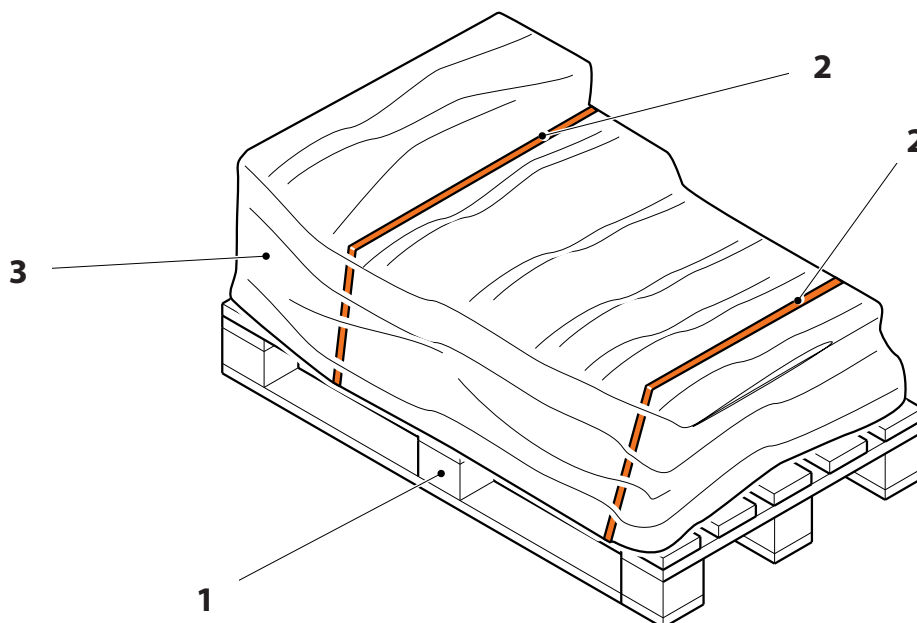



To unpack the machine, proceed as follows:

- › Move the package to the required site, using a lift truck **4** with appropriate payload.

## WARNING

For the weight of the machine, see the value indicated on the second cover of this manual.



## CAUTION

The forks are to have a suitable length to avoid unbalancing of the load, which could cause overturning and consequent damage to the machine.

- › Using appropriate cutting tools, carefully remove the straps **2** and the protective wrapping **3**.
  - › Take care not to damage the machine components with the cutting tools.
- › Carry out all the pre-starting checks (for the procedure, see chapter 5).
  - › If the battery is disconnected and/ or missing, proceed as indicated in paragraph "5.4.5. Battery connection/presence check".
  - › If the fuel level is low, proceed as indicated in paragraph "5.4.1. Refuelling".
- › Start the machine (for the procedure, see chapter 5).
- › Slowly pilot the machine (for the procedure, see chapter 5) and bring it down from the pallet **1** of the packaging, placing it on the ground.

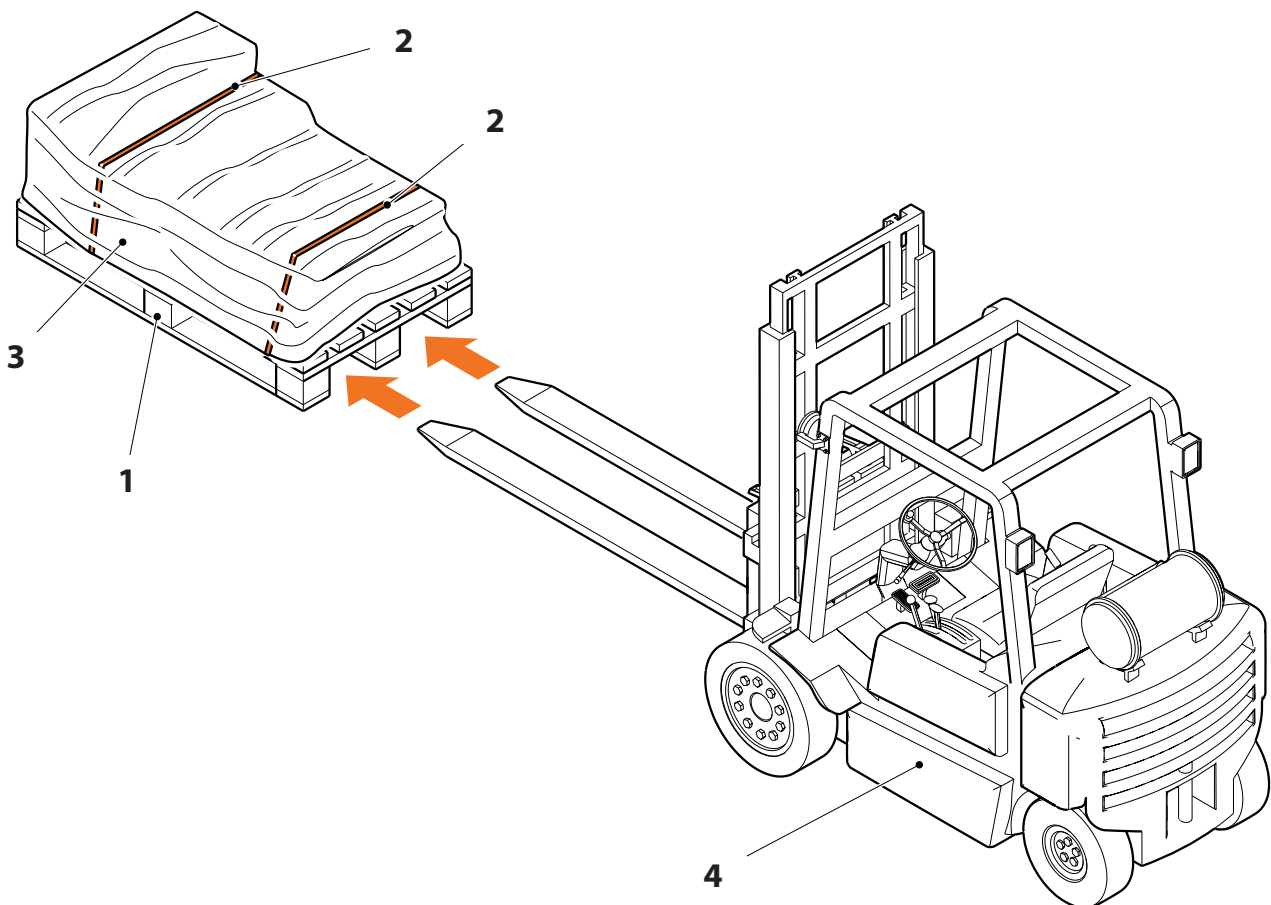



## 4.2 LIFTING

The machine can be lifted by the following methods:

- › Lifting with crane, hoist, bridge crane.
- › Lifting with lift track.



### DANGER

**The above methods are only to be applied for lifting to transfer the machine onto a suitable transport vehicle (as indicated in paragraph "4.3. Transport"). No other use is permitted.**

**It is strictly forbidden to carry out any type of maintenance with the machine lifted.**

### WARNING

**For the weight of the machine see the value indicated on the second cover of this manual.**



### 4.2.1 LIFTING WITH CRANE, HOIST, BRIDGE CRANE



## CAUTION



The lifting equipment (ropes or chains) must be suitably sized to the weight of the machine.

The lifting equipment (ropes or chains) is not supplied by MDB.

The operator is to wear the following personal protection equipment:

- › Safety shoes
- › Protective gloves
- › Hard hat
- › Protective clothing
- › Protective goggles

Proceed as follows:

- › If the tracks are in wide position, narrow them (for the procedure see chapter 5) to bring the machine to the work and movement configuration, as indicated in "3.6 Machine configurations".
- › Connect the shackles **1** to the eyebolts **2** on the machine.
  - › The arrangement of the eyebolts **2** is indicated by symbols **3**.
- › Connect the lifting equipment **4** (ropes or chains) to the hook **5** of the chosen lifting device (crane, hoist or bridge crane).
- › Lift the machine and position it on the relevant site.
- ›

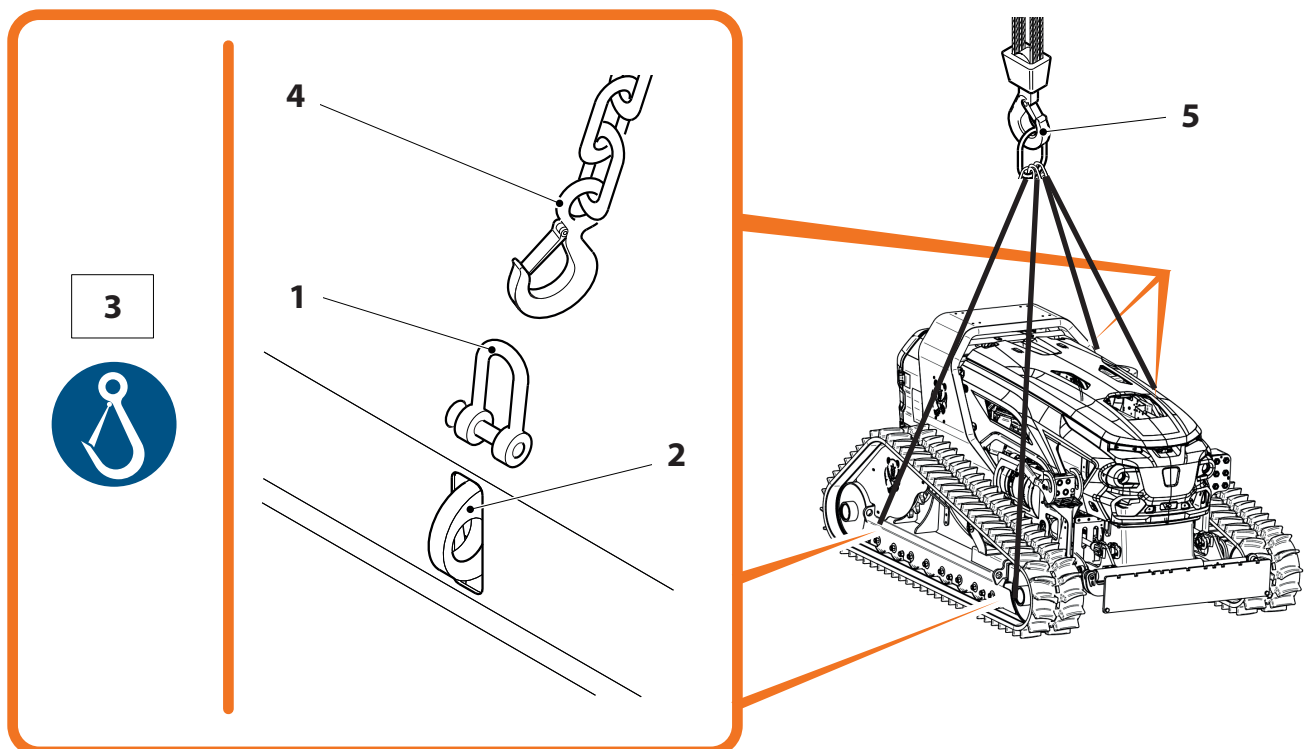



### 4.2.2 LIFTING WITH LIFT TRUCK



## CAUTION

The lift truck is to be appropriately dimensioned to the weight of the machine.



The operator is to wear the following personal protection equipment:

- › Safety shoes
- › Protective gloves
- › Hard hat
- › Protective clothing
- › Protective goggles

Proceed as follows:

- › If the tracks are in wide position, narrow them (for the procedure see chapter 5) to bring the machine to the work and movement configuration, as indicated in "3.6 Machine configurations".
- › Arrange the forks **1** at an appropriate distance between them, to ensure stability of the load.



## CAUTION

The forks are to have a suitable length to avoid unbalancing of the load, which could cause overturning and consequent damage to the machine.

- › Insert the forks **1** from the side indicated in the figure.
  - › The bottom of the machine frame is able to sustain the forks **1** of the lift truck.
- › Lift the machine and position it on the relevant site.

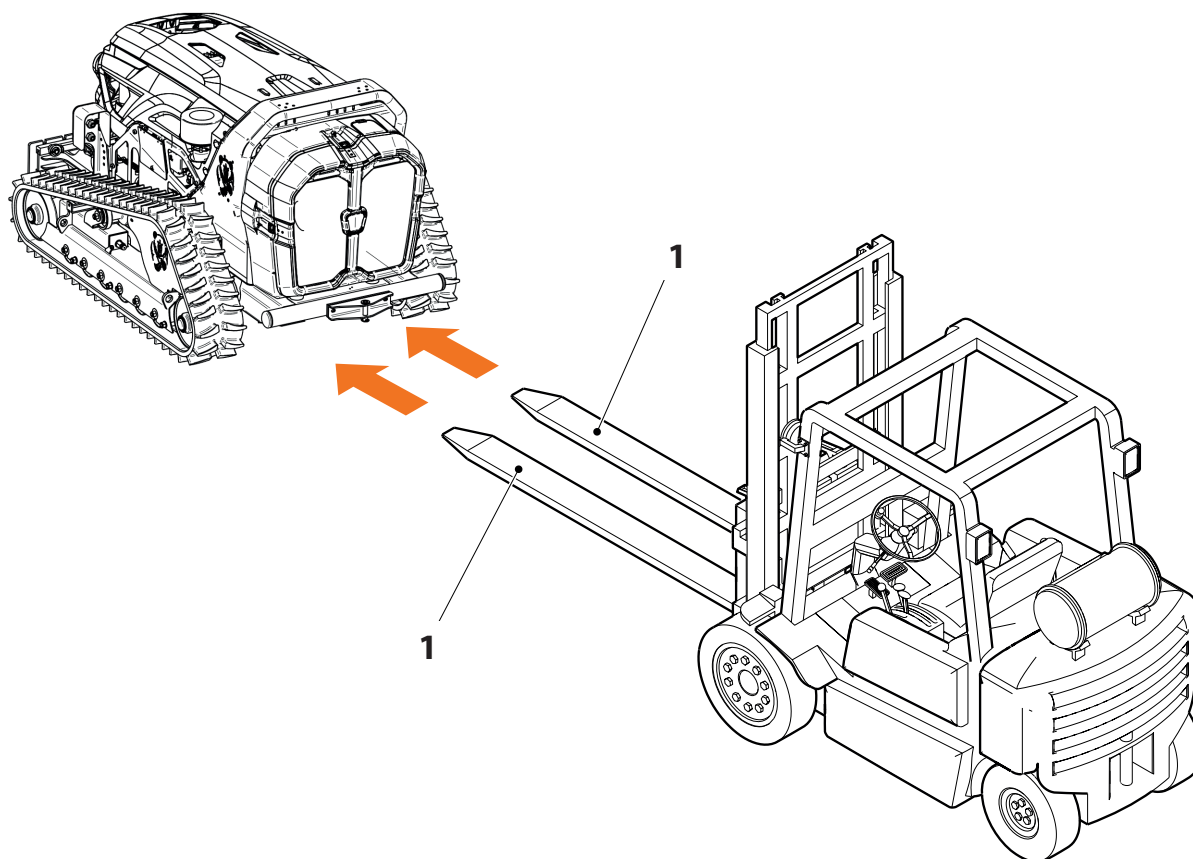



### 4.3 TRANSPORT

If necessary, the machine can be transported on a transport vehicle.



## CAUTION

The transport vehicle and related ascent/descent ramps are to be appropriately dimensioned to the weight of the machine.



The operator is to wear the following personal protection equipment:

- › Safety shoes
- › Protective gloves
- › Hard hat
- › Protective clothing
- › Protective goggles



## WARNING

For the weight of the machine see the value indicated on the second cover of this manual.

To load the machine, proceed as follows:

- › Start the machine (for the procedure see chapter 5).
- › If the tracks are in wide position, narrow them (for the procedure see chapter 5) to bring the machine to the work and movement configuration, as indicated in "3.6 Machine configurations".
- › Slowly pilot the machine (for the procedure see chapter 5) and raise it by means of the ramps **1**, to position it in the zone prepared for the transport.
- › Anchor the machine to the transport vehicle with appropriately dimensioned ropes, to be fixed to the eyebolts **2**.
- › Switch off the machine (for the procedure see chapter 5).

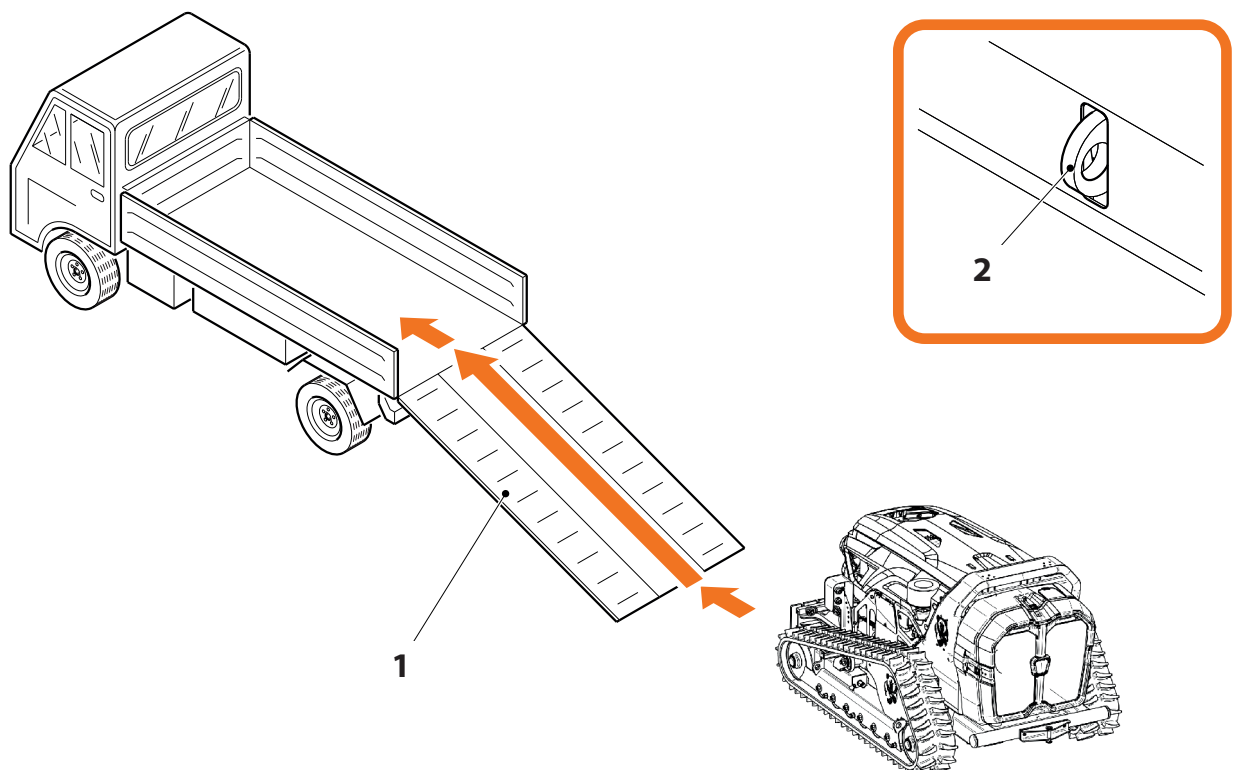



To unload the machine, proceed as follows:

- › Free the machine from the transport vehicle, removing the appropriately dimensioned ropes from the eyebolts **2**.
- › Start the machine (for the procedure see chapter 5).
- › Slowly pilot the machine (for the procedure see chapter 5) and bring it down by means of the ramps **1**, to position it in the work zone.
- › Use the machine (for the procedure see chapter 5).

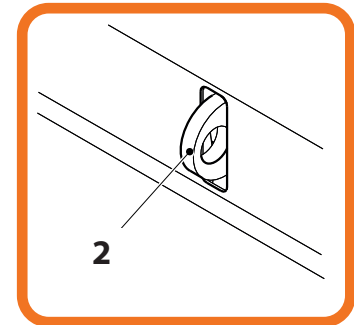
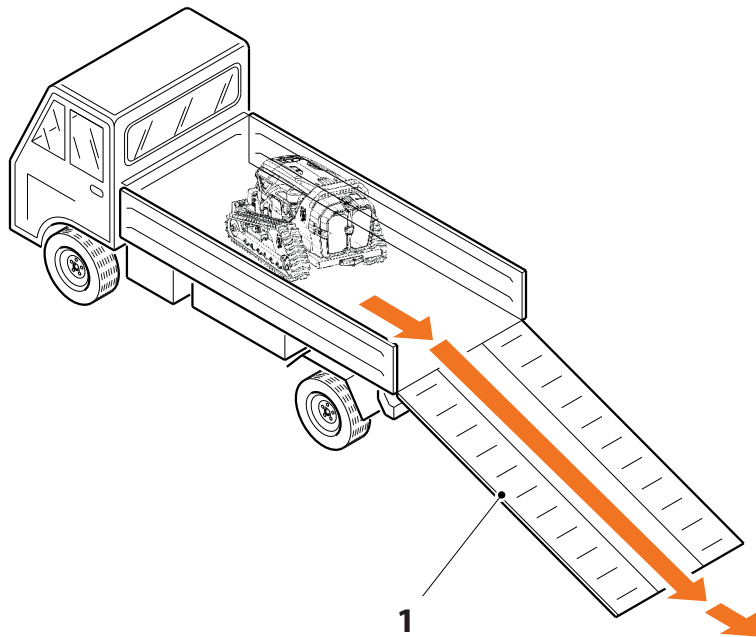

## WARNING

The loading/unloading of the machine into/from a transport vehicle can also take place with the methods described in the previous paragraphs ("4.2.1 Lifting with crane, hoist, bridge crane" and "4.2.2 Lifting with lift truck").



## 5 OPERATION AND USE

### WARNING

Before commissioning the machine, please read the following carefully and follow the instructions given.

#### 5.1 CONTROL PANEL

Control panel **1**, positioned as shown in the figure, consists of:

- › Display **2**
- › Function keys **3**
- › Key switch for ignition **4**
- › Emergency button **5**

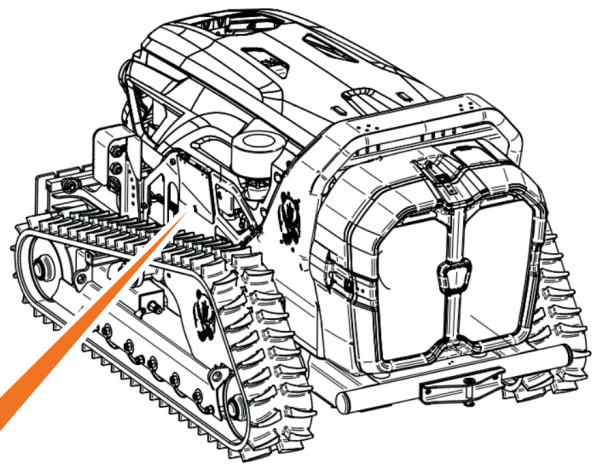
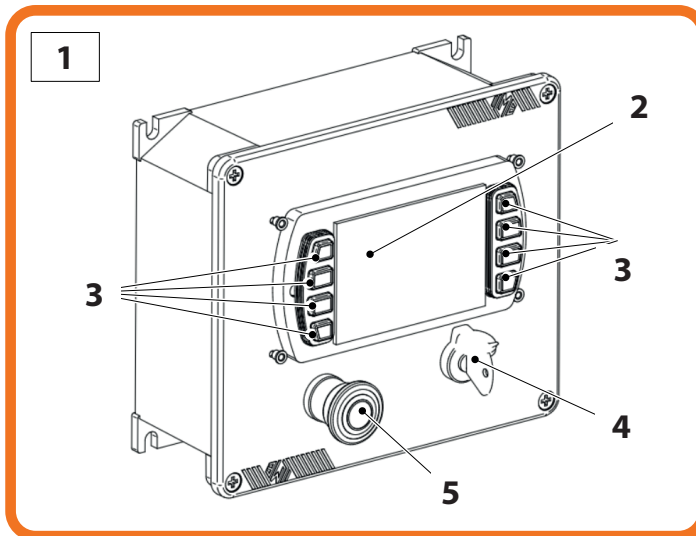



### 5.1.1 DISPLAY

The display can be considered the interface for the machine user, for reading and setting the machine. The map of the various menus is shown below:

On the sides of the display are buttons that activate the functions and/or menu pages indicated in their correspondence.



### DISPLAY BUTTONS

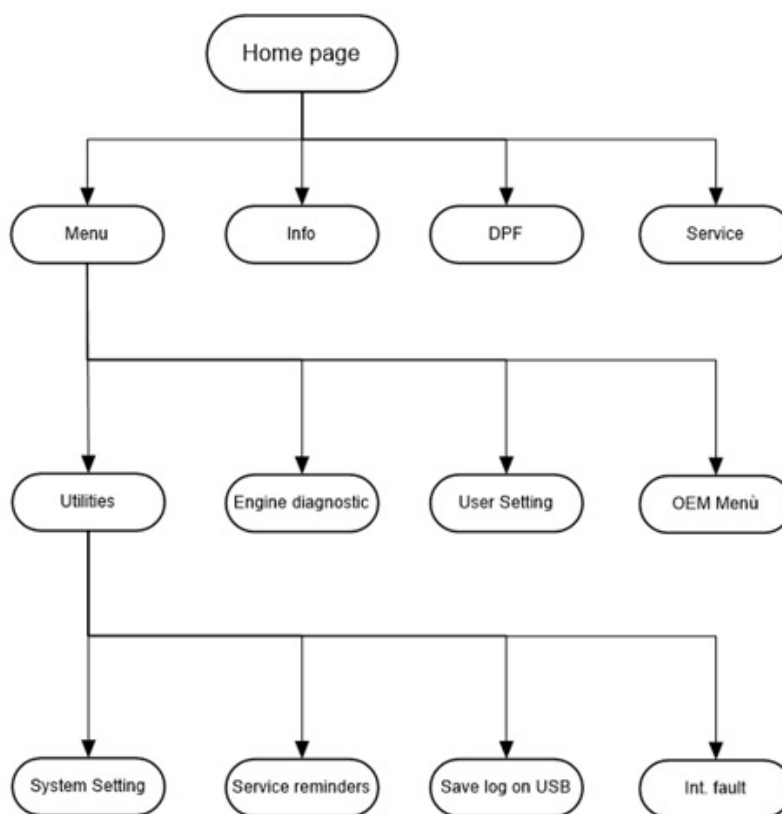



## 5.1.2 DISPLAY MENU

### HOME PAGE





On the home page, all engine information is available such as:

- › Diesel level
- › Engine temperature
- › Engine Rpm
- › Date and time
- › Battery voltage
- › Instantaneous diesel consumption
- › Air temperatur
- › Engine hours
- › Engine power consumption
- › Warning lights for battery, oil and glow plug
- › Particle filter regeneration warning light (if fitted)
- › Tandem pump pressure warning light (optional)
- › Implement pump pressure warning light (optional)
- › Glow plug light (will only come on automatically at temperatures below 0 °C)

From the Home page, by pressing the button corresponding to the submenu position, it is possible to enter the various pages dedicated to setting and displaying various information.

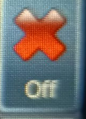

## SERVICE SUBMENU

SERVICE REMINDERS		INTERVAL	NEXT	REMAINING	Recall
↑	CHANGE ENGINE OIL	0	0	0	 Edit  Off  Reset
	CHANGE AIR FILTERS	250	0	0	
↓	CHANGE HYDRAULIC OIL	1000	0	0	
	SERVICE ENGINE	500	0	0	
	SERVICE MACHINE	0	0	0	
↶	TOTAL ENGINE HOURS			0	

The preset services are:

- › Engine oil change, air filter, hydraulic oil, general engine and machine service.
- › Time is managed through three columns, respectively: Interval, Next and Remaining.
  - › INTERVAL: Indicates the interval in hours between services of the selected item.
  - › NEXT: Indicates the hours to the next service of the selected item.
  - › REMAINING: Indicates the hours remaining until the next service of the selected item..

The buttons for setting these items are:

- › The EDIT button allows a specific number of hours to be set for the next service of the selected item.
- › The OFF button resets the selected entry to zero.
- › The Reset button resets the next service.



## INFO SUBMENU

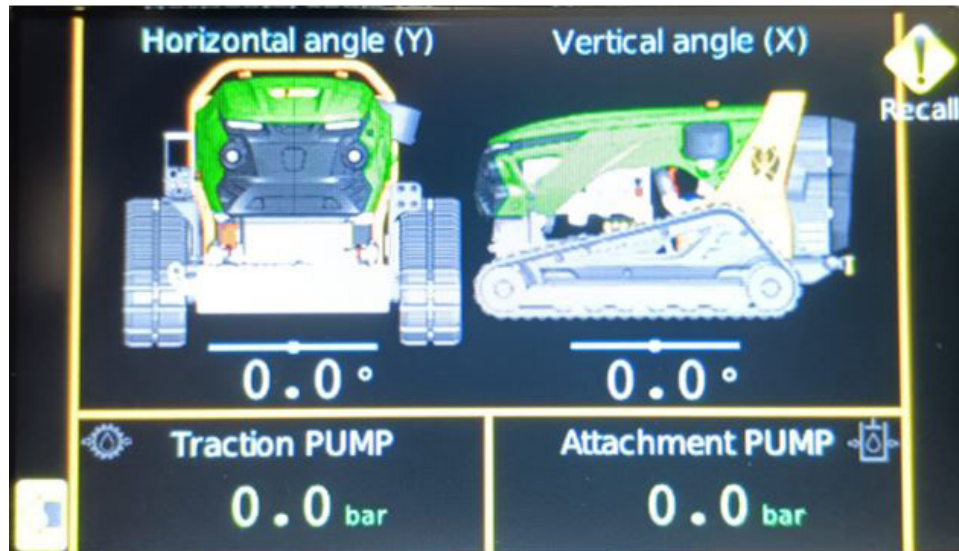

In this section it is possible to monitor the position of the machine in degrees of slope on the X and Y axis, and it is also possible to check the pressure of the traction and implement pumps (optional).

## FIRST LEVEL SUBMENU

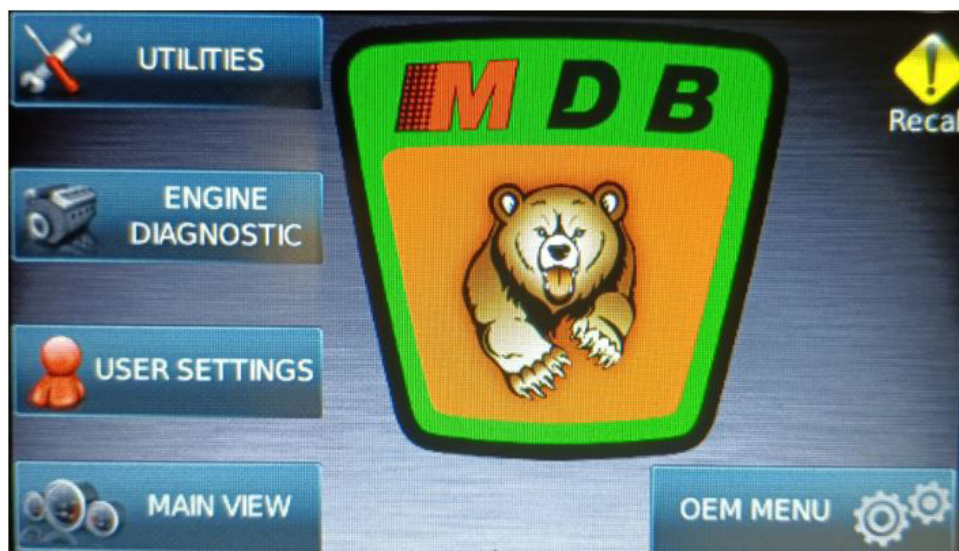

As soon as you enter the menu item, you enter a further page of choice, from here you can travel between the items:

- › Utilities
- › Engine diagnostic
- › User settings
- › OEM Menu



## SECOND LEVEL UTILITIES SUBMENU

"Utilities" allows access to a second-level submenu where we find:

- › System settings (allows the display firmware version to be displayed)
- › Service reminders (Service page described in the "Home page" section)
- › Save log on usb (Allows you to save a log on a usb stick)
- › Internal fault

## ENGINE DIAGNOSTIC

Allows active motor errors to be read out.

## USER SETTINGS

This page allows the machine to be set up according to user preferences.

- › Ambient light: allows you to set the brightness of the display according to two preset levels
- › Brightness: allows you to set the display brightness of the item selected in "Ambient light".
- › Units: allows you to select the units for reading pump pressures between Metric bar, Metric kPa, British Standard and USA Standard.
- › Language: allows you to set the desired display language.
- › Date: allows you to set the date shown on the display.
- › Time: Allows setting the time format 12h or 24h, and the time shown on the display.
- › Steering map: Three different types of steering response can be selected here:
  - › Natural: steering directly proportional to joystick tilt.
  - › Sensitive: slightly delayed steering at the start of the joystick tilt, resulting in less abrupt steering.
  - › Dynamic: more aggressive steering at the start of the joystick tilt, resulting in more reactive steering.
- › Antistall: this setting, when set to ON, activates the antistall function. The machine senses if the system draws more kW and cuts the power for the traction pumps accordingly. The saved power is automatically transferred to the implement pump.
- › Max pump displacement: this setting makes it possible to determine the maximum displacement of the traction pumps by decreasing or increasing the value the machine speed is reduced or increased accordingly.
- › Counter rotation speed: this setting can vary the speed of the machine during counter rotation.

## OEM MENU

Reserved menu for the specialised workshop.



### 5.1.3 DESCRIPTION OF POSSIBLE WARNING/ERROR MESSAGES

Warnings may appear on the home page of the display, they may be of different colours to distinguish them by severity and always have a description explaining their nature.

Description of warning colours:

- › GREEN: warns the user that the reported alarm has been resolved, so no intervention is required.
- › YELLOW: these are alerts that may require intervention by the user, they are generic alerts such as "service" to be carried out, or more targeted such as "low diesel level", "air filter clogged" etc.
- › RED: these are alarms that can also cause the vehicle to stall; they may concern anomalies in the engine or the hydraulic part. If an alarm of this colour is found, contact the authorised workshop and communicate the "SPN" and "IMF" that identifies the fault.

Possible warning or error codes are:

SPN	Intermittent message	Led on radio
6000	Can error (radio)	
6001	Can error (angle sensor)	
6002	Fuel level is low	Intermittent
6003	Service remind "change engine oil"	Fixed
6004	Service remind "change air filter"	Fixed
6005	Service remind "change hydraulic oil"	Fixed
6006	Service remind "check engine"	Fixed
6007	Service remind "check machine"	Fixed
6008	Angle X or Y is too much. Shutdown	Fixed
6009	Hi coolant temp (Step 1)	Intermittent

SPN	Continuous Message	Led on radio
6010	Low battery	
6011	Can error (Radio)	
6012	Can error (PDM1)	
6013	Can error (Micro)	
6014	Engine oil pressure is low	Fixed
6015	Hi coolant temp (Step 2)	Fixed
6016	Traction pump low pressure	Fixed
6017	Attachment pump low pressure	Fixed
6018	Angle X or Y is too much	Fixed
6020	Valve 1 error (PDM1)	



Of these signals, the most important ones for the user are displayed on the machine's radio control unit by means of the LEDs on it (yellow and red) and the acoustic signals via the buzzer.

Sound signals on the radio:

spn 6002	2 beeps of 1 second
spn 6003, 6004, 6005, 6006, 6007	1 beep of 2 seconds
spn 6018	2 beeps of 1 second
spn 6008	2 2-second beeps and engine stop
spn 6009	2 beeps of 1 second
spn 6015	2 2-second beeps and engine stop
spn 6014	2 2-second beeps and engine stop
spn 6016	2 beeps of 1 second
spn 6017	2 beeps of 1 second



### 5.1.4 DPF REGENERATION FOR KHOLER -KDI 1903 TCR STAGE V ENGINES

The Kohler 1903 and 2504 KDI TCR engine has several stages of particle filter regeneration.

- The '0' level of regeneration is with a FAP plugging threshold from 0% to 30%, it occurs fully automatically.
- The first level is when the DPF status goes from 30% to 80%, it is called assisted passive regeneration. It is fully automatic.
- The second level of regeneration occurs when the DPF state passes to a value between 80% and 90%. It is called automatic regeneration, during this process it is allowed to continue working.

## WARNING

**For the first three levels it is possible to disable regeneration for working in dusty environments to reduce possible fire hazards.**

From the machine display, select the button: 

The corresponding indicator light in the machine and on the remote control will light up 

The indicator light indicating automatic regeneration in progress on the machine and remote control display is as follows:





- The third regeneration level indicates a particle filter blockage level of 90% to 100%, the warning light on the machine display and on the remote control display is yellow and constant . The machine has to be stopped and the regeneration process has to be started directly from the machine via the dedicated command on the display page.

When regeneration is to be activated, the engine temperature must be  $>60^{\circ}$  and the accelerator potentiometer set to 0 for the entire duration of regeneration. The machine cannot and must not be operated during regeneration, it must be placed in a clean and open area.

Once regeneration is activated, the yellow light will turn green and remain lit 

The green light (AKT, 5th from left) will turn on on the remote control display, the engine will accelerate on its own and once the DOC temperature of  $340^{\circ}$  is reached, the second red light will turn on 



- The fourth level occurs when the DPF goes to a state of 100% to 110% clogging, the machine must be stopped and the regeneration procedure started from the display. The light status is flashing green  and the machine goes into the first level of derating (55% of available torque).
- Fifth level, filter clogged more than 110%, service must take action for forced regeneration. Engine switches to the second level of derate (45% of available torque) Red flashing light .

### First to third level:

- › 80-90%
- › Level 2
- › When the coolant temperature is  $>60^{\circ}\text{C}$  and the engine is running in the range shown in the graph on the right, the combustion strategy is modified as follows:
  - › Intake Accelerator + After Injection to increase DOC inlet temperature above  $300^{\circ}\text{C}$  (temperature light off DOC)
  - › When DOC inlet temperature has reached  $300^{\circ}\text{C}$ , Late Injection starts to increase DPF inlet temperature above  $450^{\circ}\text{C}$
- › No driver/command input to start, command inhibit
- › No specific safety conditions to be met

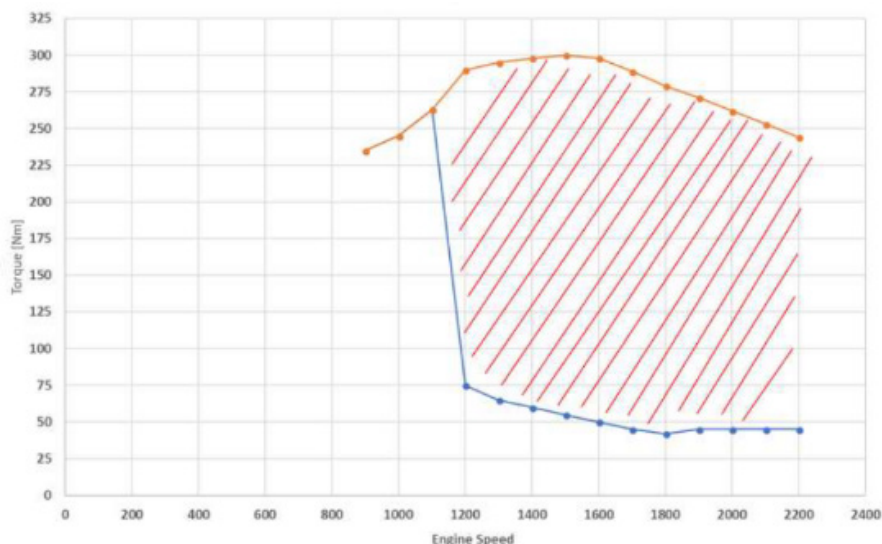

**Fourth and fifth level:**

Manual/Forced/Parking/Standstill/User

Commanded regeneration

- › 90-100% - No downgrade, 100-110% - 1st level of engine downgrade
- › Level 3 and Level 4
- › Coolant temperature >60°C
  - › Intake Accelerator + After Injection to raise the exhaust temperature in the DOC inlet above 300°C (DOC light-off temperature)
  - › When DOC inlet temperature has reached 300°C, After Injection late starts to increase DPF inlet temperature above 450°C
- › Driver/control input required to request regeneration
- › Safety conditions must be fulfilled before the ECU can start regeneration (stationary machine, idling, no pedal operation, customer responsibility for safety logic)
- › The machine is not usable until regeneration is finished/failed/safety conditions have been fulfilled
- › Temperatures in the range 450°C - 600°C
- › Preset speed - 1800 rpm

**Sixth level:**

- › 110%+ - 2nd and highest level of engine downgrade
- › Level 5
- › Performed in service workshops by qualified professionals
- › Initial ramp-up of soot combustion is low because the DPF is full of soot and poses a safety risk
- › From ~45 minutes (quick service) to 90 minutes (full service), depending on soot level

**Derate levels:**

Engine downgrading

- › Injection quantity limited according to derating level
- › 1st level - 40% less quantity injected, resulting in 55% available torque - LEVEL 4
- › 2nd level - 60% less quantity injected, resulting in 45% available torque - LEVEL 5



## REMOTE CONTROL DISPLAY LIGHTS



*DPF levels on the remote control display*

**Level "0/1/2":** warning light 4 will come on during automatic regeneration, if regeneration is deactivated via the control on the car's display, warning light 7 will come on.

**Level "3":** warning light 1 constant yellow will come on if the machine considers that static regeneration should be carried out, together with acoustic warnings from the radio.

When static regeneration is initiated by the appropriate control on the machine, control light 5 will light up green and then control light 4 will light up yellow when the DOC temperature of 340° is reached.

**Level "4":** warning light 2 yellow and 3 red will come on if the machine considers that static regeneration should be carried out, together with acoustic warnings from the remote control.

When static regeneration is started from the control on the machine, control light 5 green and then control light 4 yellow will light up when the DOC temperature of 340° is reached.

**Level "5":** lamps 3 and 6 will light up red and indicate that static regeneration by qualified personnel is required, the remote control will emit audible beeps



### Regeneration Procedure

Press the button as shown in the figure.



The DPF regeneration area is accessed.





Disabling automatic regeneration.

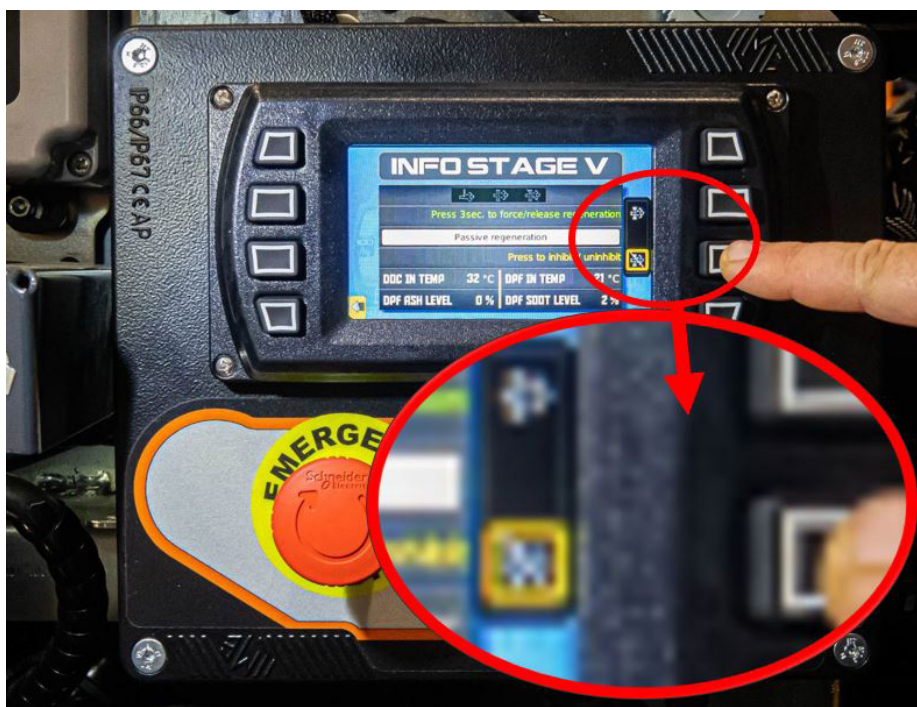

Disable automatic regeneration completed.

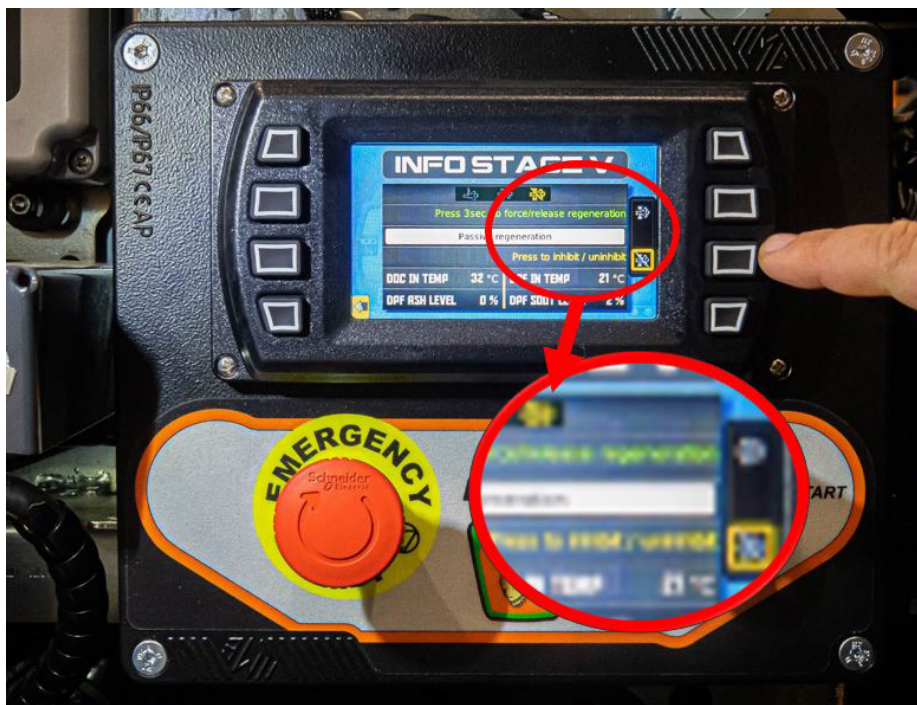



Static regeneration start trigger button.



Static regeneration start-up confirmation.

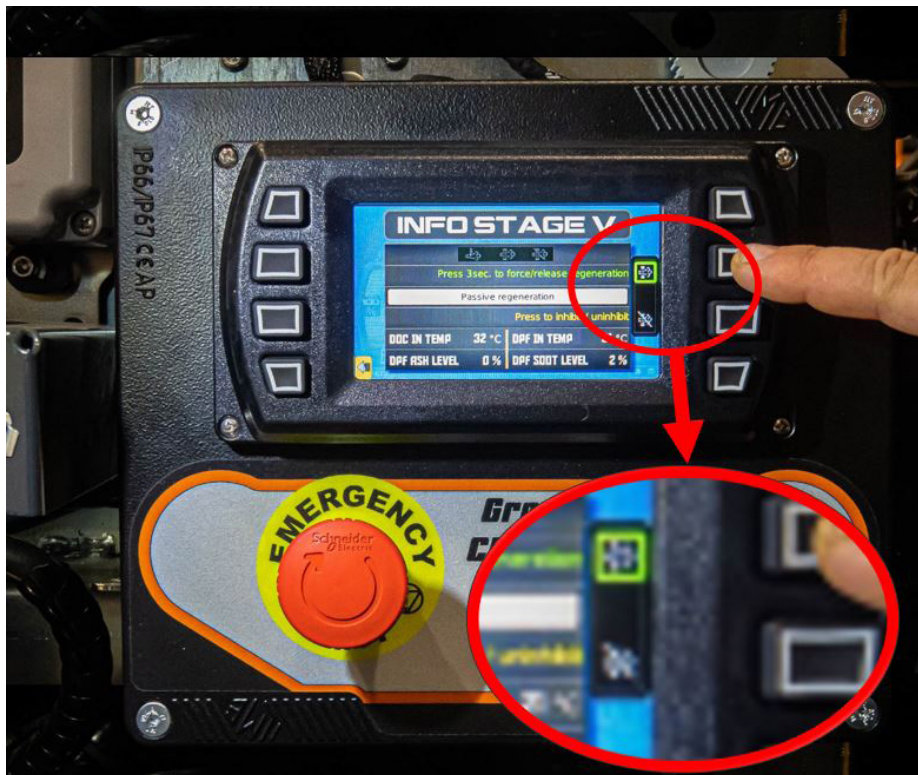



Exit menu.



Return to main screen.





5.1.5 ALARMS

N.	Code P	Name	Description	CAN			
				RS	AW	SPN	FMI
1	P0122	ACCP1L	Signal accelerator pedal sensor no. 1 too low	1		91	4
2	P0123	ACCP1H	Signal accelerator pedal sensor no. 1 too high	1		91	3
3	P0222	ACCP2L	Signal accelerator pedal sensor No. 2 too low	1		29	4
4	P0223	ACCP2H	Signal accelerator pedal sensor No. 2 too high	1		29	3
5	P0113	THAH	Air temperature sensor - signal too high	1		105	3
6	P0112	THAL	Air temperature sensor - signal too low	1		105	4
7	P0118	THWH	Coolant temperature sensor - signal too high	1		110	3
8	P0117	THWL	Coolant temperature sensor - signal too low	1		110	4
9	P0238	PIMH	Charge pressure sensor - signal too high	1		102	3
10	P0237	PIML	Fuel rail pressure sensor - signal too low	1		102	4
11	P0193	PCH	Fuel rail pressure sensor - signal too high	1		157	3
12	P0192	PCL	Fuel rail pressure sensor - signal too low	1		157	4
13	P2229	PATMH	Atmospheric pressure sensor - signal too high	1		108	3
14	P2228	PATML	Atmospheric pressure sensor - signal too low	1		108	4
15	P0563	VBBH	Vehicle system voltage too high (> 16 V)	1	1	168	3
16	P0562	VBBL	Vehicle system voltage too low (< 8 V)	1		168	4
17	P0642	VCC1L	Reference circuit 1 battery 5V low (5V sensor supply)	1		3509	4
18	P0643	VCC1H	Reference circuit 1 battery 5V high (5V sensor supply)	1		3509	3
19	P0652	VCC2L	Reference circuit 2 5V battery low (5V supply for sensor)	1		3510	4
20	P0653	VCC2H	Reference circuit 2 5V battery high (5V supply for sensor)	1		3510	3



N.	Code P	Name	Description	CAN			
				RS	AW	SPN	FMI
21	P2148	BSTWV1	Short circuit to BATT injector drive system output COM1, Short circuit to BATT injector output Injector1 or Injector4 (4-cylinder engine)/Injector1 or Injector2 (3-cylinder engine)	1		523350	3
22	P2147	GSTWV1	Short circuit to GND output injector drive system COM1, Short circuit to GND output Injector1 or Injector4 (4-cylinder engine)/Injector1 or Injector2 (3-cylinder engine)	1		523350	4
23	P2146	NCCOM1	Open circuit injector drive system output COM1, Open circuit to both Injector1 and Injector4 (4-cylinder engine)/Injector1 or Injector2 (3-cylinder engine)	1		523350	5
24	P2151	BSTWV2	Short circuit to BATT drive system output Injector COM2, Short circuit to BATT output Injector2 or Injector3 (4cil engine)/Injector3 (3cil engine)	1		523352	3
25	P2150	GSTWV2	Short circuit to GND output injector drive system COM2, Short circuit to GND output Injector2 or Injector3 (4cil engine)/Injector3 (3cil engine)	1		523352	4
26	P2149	NCCOM2	Open circuit injector drive system output COM2, Open circuit to both Injector2 and Injector3 (4-cylinder engine)/Injector3 (3-cylinder engine)	1		523352	5
27	P0201	NCTWV1	Open circuit injector1 output, open circuit injector coil	1		1393	5
28	P0203	NCTWV2	Open circuit injector output3, open circuit injector coil	1		1394	5
29	P0204	NCTWV3	Open circuit output injector4 (4cyl engine) /Injector2 (3cyl engine), open circuit injector coil	1		1395	5
30	P0202	NCTWV4	Open circuit injector output2 (4-cyl engine), open circuit injector coil	1		1396	5
31	P0611	LCHG	Injector failure - capacitor recharge circuit (low charge)	1		167	31
32	P02S00	OCHG	Injector failure - capacitor charging circuit (over-charge)	1		167	1
33	P062D	VDIC2CLK	VDIC2 (IC driving injectors) internal clock error	1		697	2
34	P062B	VDIC2CMC	VDIC2 (IC driving injectors) communication error	1		697	19
35	P0607	SCPU	CPU fault; watchdog IC fault	1		2802	31
36	P0606	MCPU	CPU fault; main CPU fault	1		2802	12
37	P0601	FROM	QR data error	1		2802	14
38	P060B	ADERR	QR definition error (QR correction definition is incorrect)	1		536090	31



N.	Code P	Name	Description	CAN			
				RS	AW	SPN	FMI
39	P062A	SHUTOF	Short circuit output SCV (+) to BATT; short circuit output SCV (-) to BATT	1		536091	31
40	P1602	QRNOT	QR data not written	1		2802	13
41	P0602	QRERR	QR data error		1	2802	11
42	P1601	ABNQR	QR definition error (the definition regarding QR correction is incorrect)		1	2802	9
43	P0629	BSSCV	Short circuit output SCV (+) to BATT; short circuit output SCV (-) to BATT	1		94	3
44	P0627	DRSCV	Open circuit/short circuit SCV(+) output to GND; open circuit/short circuit SCV(-) output to GND; open circuit/short circuit SCV coil	1		94	6
45	P0336	NEPUM	Invalid crankshaft position sensor (CKP) performance	1		249	2
46	P0337	NENOP	Crankshaft position sensor (CKP) without pulse	1		249	8
47	P0342	GNOP	Camshaft Position Sensor (CMP) without pulse	1		637	8
48	P0341	GPUM	Invalid camshaft position sensor (CMP) performance	1		637	2
49	P0016	NEGUM	Crankshaft and camshaft synchronous error	1		190	2
50	P1219	PLACT	Pressure limiter (P/L pressure limiter) active	1		156	14
51	P1219	PLVHIRP	Multiple high rail pressure errors / Engine stalling after PLV opening	1		156	2
52	P1220	PCOVR	The rail pressure control cannot reach the fuel target		1	157	31
53	P1221	PCUND	Rail pressure falls below target pressure control limit	1		157	1
54	P0615	STSWBT	Short circuit starter switch to BATT		1	430	3
55	P0503	SPDH	Vehicle speed sensor frequency too high		1	84	8
56	P0502	SPDL	Vehicle speed sensor short circuit/open input		1	84	5
57	P0501	SPDSG	Vehicle speed sensor signal invalid		1	84	2
58	P0219	NEOR	Engine overspeed condition		1	190	0
59	P0191	PCP	Rail pressure sensor signal - holding intermediate level	1		157	9



N.	Code P	Name	Description	CAN			
				RS	AW	SPN	FMI
60	P0191	PCO	PC sensor offset diagnosis (drift up or down)	1		157	2
61	P0191	PCOH	PC sensor offset high	1		157	20
62	P0541	GRELGD	Open circuit/short circuit glow plug relay output to GND		1	626	4
63	P0542	GRELBT	Glow plug relay output short-circuit to BATT		1	626	3
64	P0617	STRYBT	Short-circuit starter relay output to battery		1	430	5
65	P0616	STRYGD	Short circuit starter switch relay to GND		1	430	4
66	U0073	CANB1	CAN1 node error		1	1083	19
67	P0183	THFFH	Fuel temperature sensor (w/pump) - signal too high	1		174	3
68	P0182	THFFL	Fuel temperature sensor (w/pump) - signal too low	1		174	4
69	P02EE	BTTWV1	Boost time-out Injector1 (No peak injection current)	1		1393	9
70	P02F0	BTTWV2	Overrun time-out Injector3 (No peak injection current)	1		1394	9
71	P02F1	BTTWV3	Boost time-out Injector4 (4-cyl engine) / Injector2 (3-cyl engine) (No peak injection current)	1		1395	9
72	P02EF	BTTWV4	Overrun time-out Injector2 (No peak injection current)	1		1396	9
73	P060C	MSC	MSC communication error	1		536092	31
74	P060D	SPIOCEAN	SPI communication error (Ocean)	1		536093	31
75	P060E	SPIATPIC	SPI Communication Error (Amb. Pressure Sensor)	1		536094	31
76	P0228	PTOPH	Accelerator pedal sensor signal for ASC (PTO) too high	1		28	3
77	P0227	PTOPL	Signal of accelerator pedal sensor for ASC (PTO) too low	1		28	4
78	P2123	PTOP2H	Sensor signal 2 accelerator pedal for ASC (PTO) too high	1		28	20
79	P2122	PTOP2L	Sensor signal 2 accelerator pedal for ASC (PTO) too low	1		28	21
80	P0077	ITHRPREH	Intake throttle position signal too high	1		51	3
81	P0076	ITHRPREL	Intake throttle position signal too low	1		51	4
82	P2280	AFC	Air filter clogging error	1		107	2



N.	Code P	Name	Description	CAN			
				RS	AW	SPN	FMI
83	P2280	PAFDL	Air filter differential pressure sensor - signal too low		1	107	4
84	P2280	PAFDH	Air filter differential pressure sensor - signal too high		1	107	4
85	P0462	FLEVL	Fuel level sensor signal too low		1	96	4
86	P0463	FLEVH	Fuel level sensor signal too high		1	96	3
87	P0191	PCNOX	PC sensor offset diagnosis for NOX requirements (drift up or down)	1		157	14
88	P00A3	THCACH	Upstream DPF temperature sensor - signal too low	1		5283	3
89	P00A2	THCACL	Ambient temperature sensor - signal too high	1		5283	4
90	P244B	DPH	DPF differential pressure signal too high	1		3251	3
91	P244A	DPL	DPF differential pressure signal too low	1		3251	4
92	P2033	THDPFH	Upstream DPF temperature sensor - signal too high	1		3242	3
93	P2032	THDPFL	Upstream DPF temperature sensor - signal too low	1		3242	4
94	P0073	THA3H	Ambient temperature sensor - signal too high		1	171	3
95	P0072	THA3L	Ambient temperature sensor - signal too low		1	171	4
96	P0546	THDOCH	Diagnosis control physical limit Ambient pressure, max.	1		3241	3
97	P0545	THDOCL	Upstream DOC temperature sensor - signal too low	1		3241	4
98	P0069	EVSTAMBPOFSCHK	Ambient pressure cross-checking		1	108	2
99	P2226	EVSTAMBPRNGPHYMAX	Downstream intercooler temperature rationality check		1	108	0
100	P2227	EVSTAMBPRNGPHYMIN	Diagnosis physical limit control Ambient pressure, min.		1	108	1
101	P009A	EVSTAMBTOSFSCHK	Ambient temperature cross-check		1	171	2
102	P0070	EVSTAMBTRNGPHYMAX	Diagnosis fixed limit control Ambient temperature, max.		1	171	0
103	P0071	EVSTAMBTRNGPHYMIN	Diagnosis physical limit control Ambient temperature, min.		1	171	1
104	P00A1	EVSTACTDSPBTTY	Downstream intercooler temperature rationality check		1	5283	31
105	P050C	EVSTCOOLTOFSCHK	Cross-check coolant temperature (with cold start)		1	110	2



N.	Code P	Name	Description	CAN			
				RS	AW	SPN	FMI
106	P011B	EVSTCOOLTSTUCK	Heating coolant temperature control		1	110	31
107	P2423	EVSTDOCRCTNEXO	DOC exothermic reaction efficiency diagnosis		1	5018	0
108	P2081	EVSTDOCTRNGUSMAX	Diagnosis control physical limit temperature upstream DOC, max.		1	3241	0
109	P042B	EVSTDOCTRNGUSMIN	Diagnosis control physical limit upstream temperature DOC, min.		1	3241	1
110	P2080	EVSTDOCTUSPLBTY	Upstream temperature rationality check DOC		1	3241	31
111	P2463	EVSTDPFMONGCLG	DPF clogging diagnosis	1		3936	0
112	P242F	EVSTASHOVL	Excessive ash detection		1	3720	0
113	P2453	EVSTDPFDIFFORMONGOFS	Offset differential pressure sensor check		1	3251	2
114	P2455	EVSTDPFDIFFORMONGPHY	Physical differential pressure sensor check		1	3251	31
115	P1205	EVSTDPFMONGRMVL	DPF removal monitoring function		1	3936	31
116	P2085	EVSTDPFTRNGUSMAX	Diagnosis control limit temperature upstream DPF, max.		1	3242	0
117	P2084	EVSTDPFTRNGUSMIN	Diagnosis control limit temperature upstream DPF, min.		1	3242	1
118	P2031	EVSTDPFTUSPLBTY	Upstream DPF temperature rationality check		1	3242	31
119	P2BAB	EVSTEGRFLOW	EGR flow		1	2659	1
120	P2413	EVSTEGRPOSN	Slow response from EGR		1	5829	10
121	P0106	EVSTINTKMNFLDPOFSCHK	Intake manifold pressure cross-check		1	102	2
122	P0236	EVSTINTKMNFLDPLBTY	Intake manifold pressure rationality check		1	102	31
123	P0111	EVSTINTKMNFLDPOFSCHK	Intake manifold temperature sensor offset check		1	105	2
124	P00AA	EVSTINTKMNFLDTPLBTYMAX	Intake manifold temperature sensor rationality check		1	105	0
125	P00AB	EVSTINTKMNFLDTPLBTYMIN	Intake manifold temperature sensor rationality check		1	105	1
126	P20E2	EVSTOFSCHKOFDOCTUS	Upstream temperature sensor cross-check DOC		1	3241	11
127	P20E3	EVSTOFSCHKOFDPFTUS	Upstream temperature sensor cross-check DPF		1	3242	11
128	P1562	EVSTSNSRTORD	Signal for sensor crossover detection	1		521272	31



N.	Code P	Name	Description	CAN			
				RS	AW	SPN	FMI
129	P007B	EVSTCACTOFSCHKDS	Cross temperature control downstream intercooler (cold start)		1	5283	2
130	P042A	EVSTDOCTUSSTUCK	Upstream DOC temperature heating control		1	3241	2
131	P2082	EVSTDPFTUSSTUCK	Upstream DPF temperature heating control		1	3242	2
132	P1217	PCEX1	Common Rail pressure exceeds upper limit1	1		157	15
133	P2293	PCEX2	Common Rail pressure exceeds upper limit2	1		157	16
134	P0088	PCEX3	Common Rail pressure exceeds upper limit3	1		157	0
135	P268B	IPMPSTDYNOT	Pump Learning not completed		1	1349	2
136	P1589	ITHRS	Intake throttle block fault	1		51	7
137	P2118	ITHRCURR	Intake butterfly current fault	1		51	8
138	P2134	ITHRCURAVE	Intake butterfly medium work fault	1		51	9
139	P2101	DCMOC	Invalid intake throttle motor drive circuit	1		51	6
140	P0524	POILDN	Low engine oil pressure	1		100	1
141	P0217	THWOT	Coolant temperature above upper limit	1		110	0
142	U1001	CANB2	CAN2 node error		1	1084	19
143	U0411	EGRNTR	Fault no transmission by EGR or receiver (for CAN)	1		2791	2
144	P0385	NEGNON	Starter motor not activated	1		190	9
145	P0263	ANGSPD1	Error1 motor angular speed (Injector1)	1		1393	2
146	P0266	ANGSPD2	Error2 motor angular speed (Injector2)	1		1394	2
147	P0269	ANGSPD3	Error3 motor angular speed (Injector3)	1		1395	2
148	P0272	ANGSPD4	Error4 motor angular speed (Injector4)	1		1396	2
149	P2269	WGTHR	Water failure in fuel filter		1	97	2
150	P0234	TBOPH	Supercharger pressure sensor exceeds upper limit	1		1127	0
151	P0299	TBOPL	Supercharger pressure sensor exceeds lower limit	1		1127	1



N.	Code P	Name	Description	CAN			
				RS	AW	SPN	FMI
152	P0694	CFANLBT	Shorted low-speed coolant fan relay to battery		1	1639	5
153	P0693	CFANLGD	Low-speed coolant fan relay short-circuit to GND		1	1639	6
154	P0696	CFANHBT	High-speed coolant fan relay short-circuit to battery	1		1639	3
155	P0695	CFANHGD	High-speed coolant fan relay short circuit to GND	1		1639	4
156	P0404	EGRBM	EGR battery/engine fault (for CAN)	1		2791	14
157	P0400	EGRFPD	EGR feedback fault/position sensor/dynamic range (for CAN)	1		2791	7
158	P0488	EGRVI	EGR valve initialisation/locking fault (for CAN)	1		2791	7
159	P2425	EGRT	EGR valve temperature fault (for CAN)	1		2791	31
160	P0403	EGRCLEAN	EGR cleaning fault (stuck valve open/poppet much lower than usual)	1		2791	13
161	U0107	TSC1TMERR	TSC1 time-out fault	1		3349	9
162	U0408	TSC1RC	Lap count test TSC1	1		3349	10
163	U0408	TSC1CS	Check sum test TSC1	1		3349	2
164	P0232	ELPUMPBT	Feed pump relay short-circuit to battery		1	4082	3
165	P0231	ELPUMPGD	Power supply pump relay short circuit to GND		1	4082	4
166	U1103	ECSTMERR	Lap count test error ECS		1	516097	9
167	U0422	ECSRC	ECS checksum test error		1	516097	10
168	U0422	ECSCS	ECS checksum test error		1	516097	2
169	P2002	STTRIGLVLACV1	DPF load level active - diagnosis activation status 1	1		4781	15
170	P246C	STTRIGLVLACV2	DPF load level active - diagnosis activation status 2	1		4781	16
171	P200C	DPFOVERTEMP	Overtemperature in DPF	1		3250	0
172	P1451	PCDMON	DPF removal (physical) monitoring function	1		3936	2
173	P0113	THAI2H	Intake manifold temperature sensor signal too high (without CAC)	1		105	3
174	P0112	THAI2L	Intake manifold temperature sensor signal too low (without CAC)	1		105	4



N.	Code P	Name	Description	CAN			
				RS	AW	SPN	FMI
175	P2A12	RSTWV1	Short-circuit coil TWV1	1		1393	6
176	P2A14	RSTWV2	Short-circuit coil TWV2	1		1394	6
177	P2A16	RSTWV3	Short-circuit coil TWV3	1		1395	6
178	P2A1C	RSTWV4	Short-circuit coil TWV4	1		1396	6
179	P0000	CANOPENCM1	Error time-out message CM1			0	0

The CANOPENCM1 diagnosis is only active if the CM1 message is used; the diagnosis lights will not be lit and the DTC P0000 will only be visible via the diagnosis tool.

An action by the system can be triggered as a consequence of any diagnosis operation:

- > XQPTN2: Rear injection inhibition
- > XQPTN1: Rear injection inhibition/pilot
- > XPCLMTLOW: Rail pressure lower limit
- > XPCLMTLEV2: Rail pressure lower limit 2
- > XPCLMTLEV1: Rail 1 pressure lower limit
- > XQLMTLEV3: Fuel quantity limit 3
- > XQLMTLEV2: Fuel quantity limit 2
- > XQLMTLEV1: Fuel quantity limit 1
- > XACCLEV3: Accelerator limit 3
- > XACCLEV2: Accelerator limit 2
- > XACCLEV1: Throttle limit 1
- > XENSTRQLEV2: Motor stop with delay
- > XENSTRQLEV1: Motor stop
- > XSYSOP03: PTO control inhibition
- > XEGRIH: EGR control inhibition
- > XITHIH: ITHR control inhibition
- > XL1ON: SVS indicator flashing flag
- > XDPFRGEMOFF: DPF regeneration inhibition
- > XTRQLMTLEV1: Torque limit 1
- > XTRQLMTLEV2: Torque limit 2
- > XTRQLMTLEV3: Torque limit 3
- > XQLMTPMLEV1: Fuel quantity limit 1 for soot accumulation
- > XQLMTPMLEV2: Fuel quantity limit 2 for soot accumulation
- > XTRQLMTPMLEV1: Torque limit 1 for soot accumulation
- > XTRQLMTPMLEV2: Torque limit 2 for soot accumulation



## 5.2 RADIO CONTROL

The radio control allows the machine to be controlled from a specific distance (refer to paragraph "3.4.1 Operator position"), and to keep the various operating functions of the machine under control. The automatic transmission frequency change avoids transferring signals on channels already occupied by other devices.

For further information on the radio control system, please refer to Annex C.

### WARNING

**This manual only deals with the radio control commands specific to the machine in question.**

**For the remaining controls, please refer to the manual for the implement that is installed on the machine..**

### 5.2.1 RADIO CONTROL DESCRIPTION WITH DISPLAY

Command	Description
<b>A</b>	Beeper (machine status warning with simultaneous operation of some LED functions)
<b>L</b>	Signalling LED
<b>F</b>	Serial socket for Filocomando, for connection between radio control and control unit (used only in the event of any interference in the radio signal, or in the event of damage to the radio control batteries)
<b>J1</b>	Right steering - Left steering / Machine movement forwards - Machine movement backwards
<b>J2</b>	Control used by installed implement (refer to implement manual)
<b>J3</b>	Auxiliary command [used for optional implements (if fitted)].
<b>J4</b>	Implement movement right - Implement movement left / Implement movement up - Implement movement down
<b>S1</b>	Lights on / Lights off
<b>S2</b>	Auxiliary control [used for optional implements (if fitted)].
<b>S3</b>	Engine speed regulator
<b>S4</b>	Floating / semi-floating tool
<b>S5</b>	Emergency button (If pressed, the machine stops and the engine shuts down. In order to restart the machine, the connection procedure between radio control and control unit must be carried out again (see following paragraphs)) / Radio control switch off
<b>S6</b>	Widening tracks / Narrowing tracks
<b>S7</b>	J1 commands normalised / J1 commands reversed



Command	Description
S8	Right-hand trajectory correction / Left-hand trajectory correction
S9	Speed regulator
S10	Radio control power button / Radio control-control unit connection button / Horn (only works when radio control and control unit are connected)
S11	Turn on radiator cleaning fan / Turn off radiator cleaning fan
S12	Control used by the installed tool (refer to tool manual)
S13	Control used by the installed tool (refer to tool manual)
S16	Engine switch-off button
S18	Engine start button

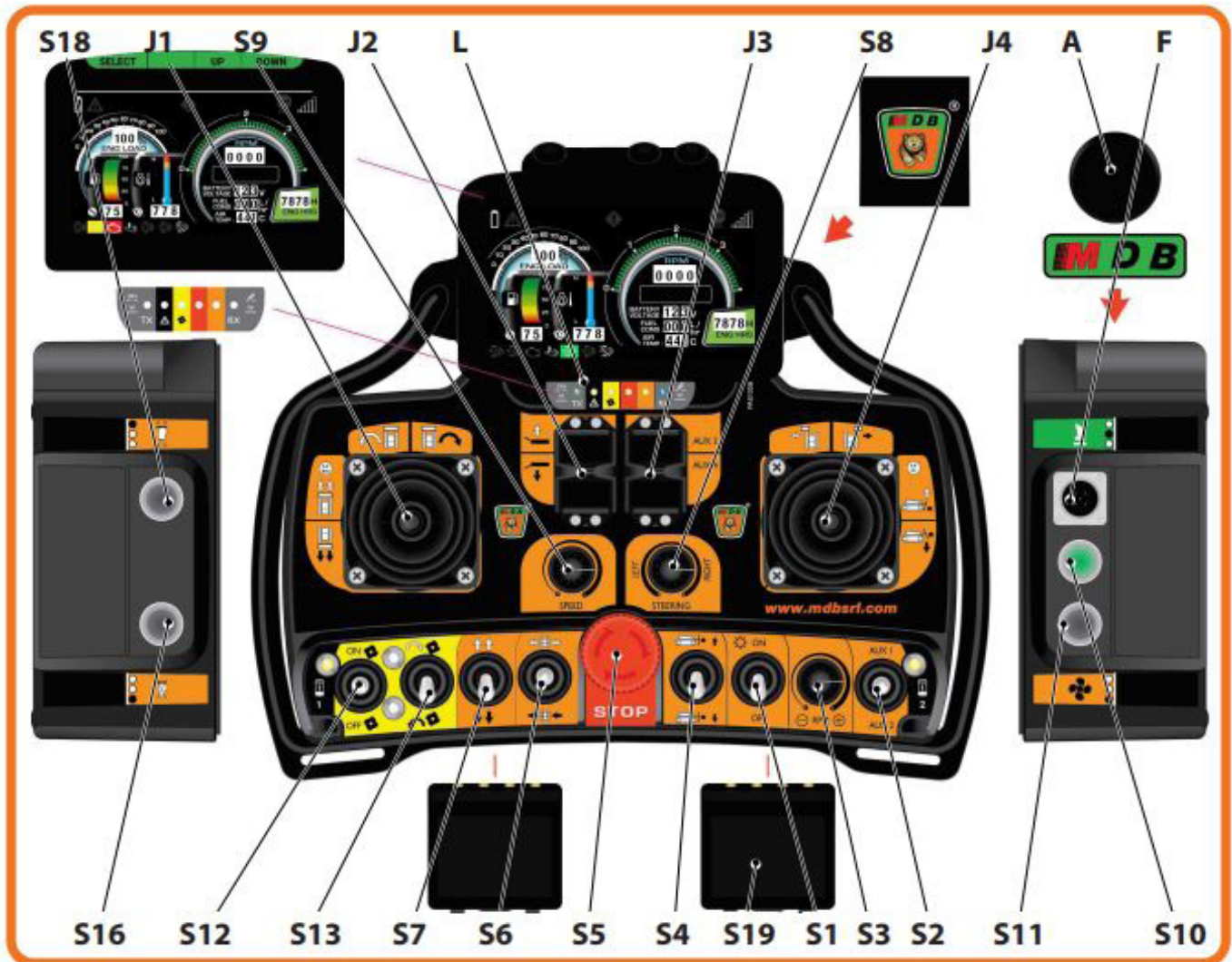



## 5.2.2 RADIO CONTROL DESCRIPTION WITHOUT DISPLAY

Command	Description
<b>A</b>	Beeper (machine status warning with simultaneous operation of some LED functions)
<b>L</b>	Signalling LED
<b>F</b>	Serial socket for Filocomando, for connection between radio control and control unit (used only in the event of any interference in the radio signal, or in the event of damage to the radio control batteries)
<b>J1</b>	Right steering - Left steering / Machine movement forwards - Machine movement backwards
<b>J2</b>	Control used by installed implement (refer to implement manual)
<b>J3</b>	Auxiliary command [used for optional implements (if fitted)].
<b>J4</b>	Implement movement right - Implement movement left / Implement movement up - Implement movement down
<b>S1</b>	Lights on / Lights off
<b>S2</b>	Auxiliary control [used for optional implements (if fitted)].
<b>S3</b>	Engine speed regulator
<b>S4</b>	Floating / semi-floating tool
<b>S5</b>	Emergency button (If pressed, the machine stops and the engine shuts down. In order to restart the machine, the connection procedure between radio control and control unit must be carried out again (see following paragraphs)) / Radio control switch off
<b>S6</b>	Widening tracks / Narrowing tracks
<b>S7</b>	J1 commands normalised / J1 commands reversed
<b>S8</b>	Right trajectory correction / Left trajectory correction
<b>S9</b>	Speed regulator
<b>S10</b>	Radio control switch on button / Radio control-control unit connection button / Horn (only works when radio control and control unit are connected)
<b>S11</b>	Radiator cleaning fan on / Radiator cleaning fan off
<b>S12</b>	Command used by installed tool (refer to tool manual)
<b>S13</b>	Control used by the installed tool (refer to tool manual)
<b>S16</b>	Engine shutdown button



Command	Description
S18	Engine start button

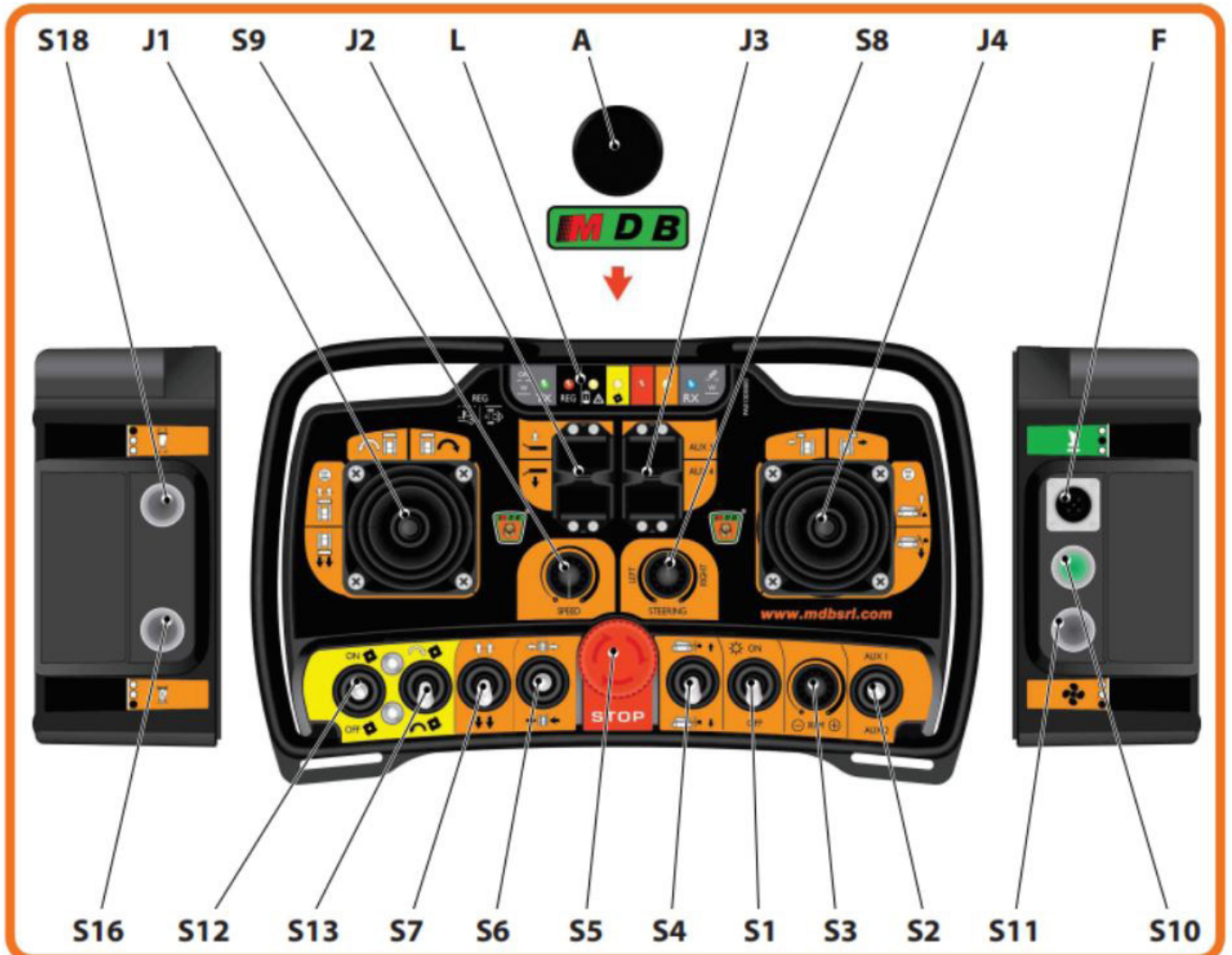



### 5.2.3 REMOTE CONTROL LED

The remote control is equipped with LEDs that signal various information to the operator:

- › The operating states of the machine
- › Operating faults
- › The type of faults
- › Diagnostic functions
- › Battery charge level

Led	Colour	Status	Description
TX	Green on grey background	On	The radio control has established a connection with the control unit
		Off	The radio remote control is switched off or has failed
		Flashing	The remote control is trying to establish a connection with the control unit
1	Yellow on a black background	Two close-up flashes with twenty-second pause	Low battery
2	/	/	Led used by the tool installed (refer to tool manual)
3	Red on red background	On	1-second acoustic signal: high engine temperature (above 105° C) (wait for reset operation) 2-second audible warning signal: low engine oil pressure (wait for reset operation)
		Flashing	High engine temperature (above 95° C) (Wait for reset operation)
4	Yellow on an orange background	On	Clogged air filter. Scheduled maintenance work indicated..
		Flashing	Fuel level at idle
5	Red on a black background	On	DPF regeneration function active
RX	Blue on a grey background	On	Control unit has established a connection with the radio remote control
		Off	Control unit is switched off or malfunctioning
			Control unit is trying to establish a connection with the remote control

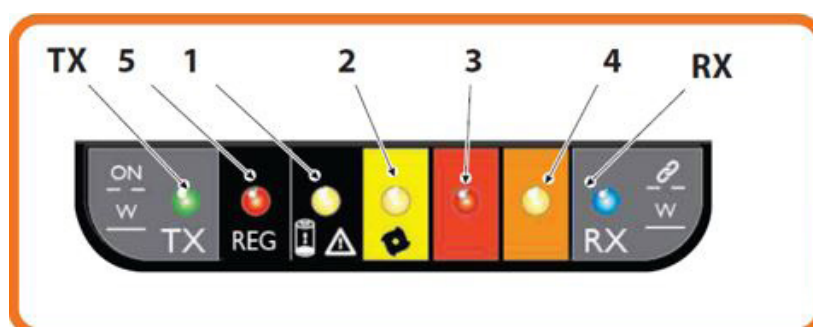



## 5.3 ON-BOARD CONTROLS

**WARNING**

To gain access to the on-board controls, the bonnet must be opened, as described in Chapter 6.

Command	Description
1	Track widening / track narrowing
2	Implement movement up - Implement movement down
3	Implement movement right - Implement movement left
AUX A-B	Auxiliary control [used for optional implements (if fitted)].
AUX C-D	Auxiliary control [used for optional implements (if fitted)].

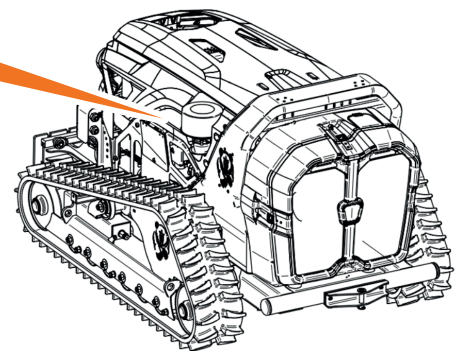
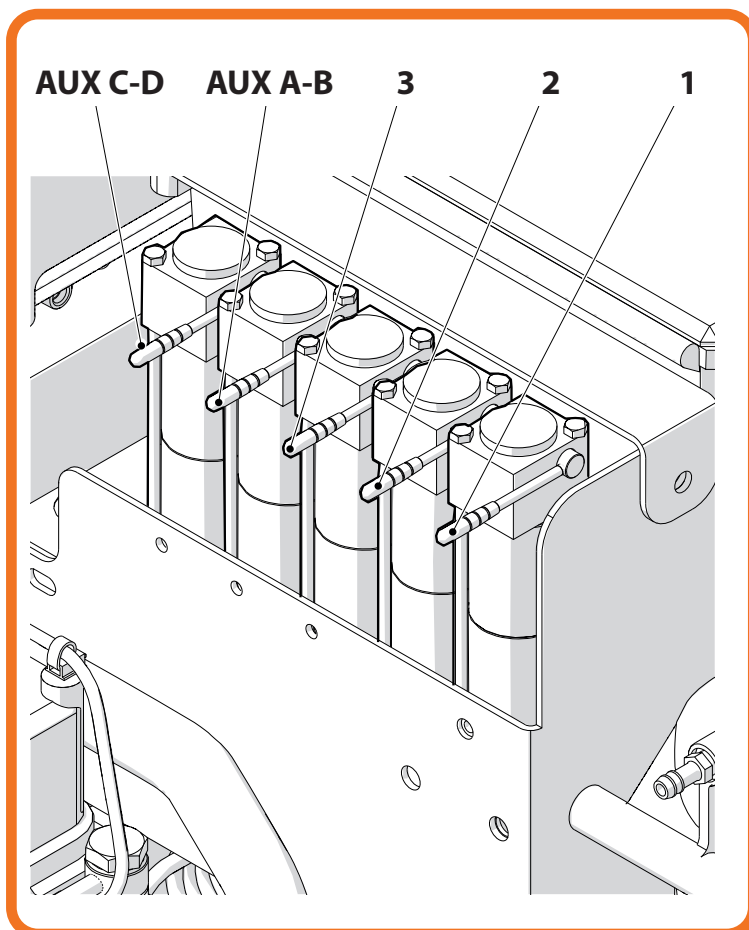



## 5.4 PRE-START CONTROLS

### WARNING

The machine is delivered in variable conditions depending on the regulations in force in the country of use.

For this reason, some of the operations listed in the following paragraphs may be superfluous, as they have already been carried out during shipment.

### WARNING

Before starting any type of operation, make sure that the ignition key is not inserted in the control panel and remove it if necessary, handing it over to the person in charge of the machine.

Before starting any type of operation, make sure that the "battery cut-off" key is in the OFF position, and remove it.

Proceed as follows:

- › Place the machine on a horizontal plane.
- › Place a sign on the control panel stating "Do not use".
- › Bar access to the area around the machine to all unauthorised persons.



## 5.4.1 FILLING UP WITH FUEL

Handle fuel with extreme care because it is highly flammable. In the event of combustion, explosions and fires can occur with the risk of serious injury.

All types of fuel are flammable. Do not burn or puncture containers.

Store flammable liquids away from potential sources of fire.

Refuelling should be carried out in a well-ventilated area.

Do not refuel near open flames and sparks.

Do not get too close to the refuelling cap in order not to inhale harmful vapours.

The operator must wear the following personal protective equipment:

- › Safety footwear
- › Protective gloves
- › Protective clothing
- › Protective goggles
- › Face mask

For the type of product used refer to Annex B.

For the quantity of product used refer to paragraph "3.3.4 Other technical specifications".

The control panel signals the minimum fuel level to the operator. Refuelling must in any case be carried out before the tank is completely empty.

 **DANGER**



**WARNING**

Proceed as follows:

- › Open bonnet **1** (as described in Chapter 6).
- › Unscrew the cap **2**.
- › Use a funnel and introduce the fuel into the tank **3**, through the inlet pipe **4**.
- › Visually check the level of fuel introduced, verifying that it touches the reference **5**.

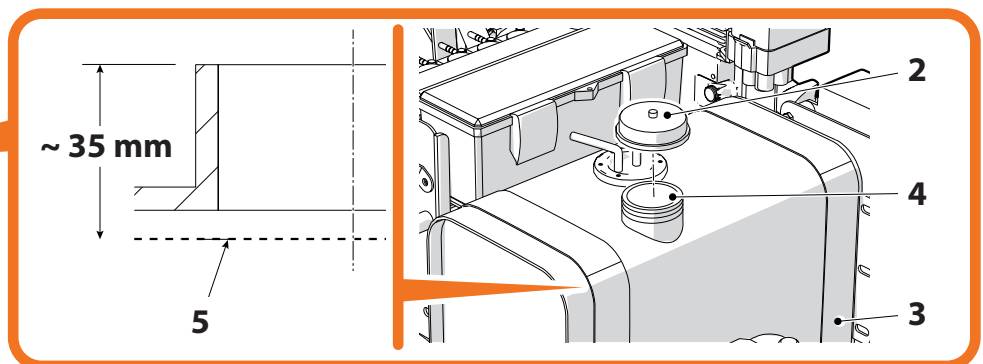
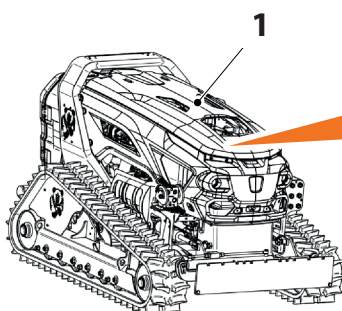



### 5.4.2 REFILLING ENGINE OIL

Proceed as follows:

- › Check the engine oil level and top up if necessary, as described in chapter 6..

### 5.4.3 REFILLING COOLANT

Proceed as follows:

- › Check the coolant level and top up if necessary, as described in Chapter 6

### 5.4.4 RIFORMIMENTO OLIO IDRAULICO

Proceed as follows:

- › Check the hydraulic oil level and top up if necessary, as described in chapter 6.

### 5.4.5 BATTERY CONNECTION/PRESENCE CHECK



**DANGER**

The liquid contained in the battery may explode.



Connect the terminals to the correct electrical poles. Failure to do so may result in damage to electrical parts or fire.

Proceed as follows:

- › Open bonnet **1** (as described in Chapter 6).
- › Turn the "battery disconnect" key to the OFF position, and disconnect it (refer to the following paragraphs for the procedure).
- › Locate the battery.
- › Connect the connection cables to the respective battery poles.
  - › Rispettare l'accoppiamento con polo negativo e polo positivo identificato dal relativo simbolo.

**WARNING**

If the machine does not have a battery, proceed with the installation in accordance with the specifications in section "3.3.4 Other technical specifications".



## 5.5 START-UP

The machine can be started up in two distinct modes:

- › Manual start
- › Starting with radio remote control

### 5.5.1 MANUAL START

Proceed as follows:

- › Ensure that the emergency button **1** is not pressed.
- › Open the bonnet **2** (as described in Chapter 6).
- › Insert the "battery cut-off" key **3**, and turn it to the ON position.
- › Close bonnet **2**.
- › Insert the ignition key **4** and turn it to the ON position.
  - › Red lights **5** come on steady, white lights **6** come on steady, yellow lights **7** come on flashing.
  - › A prolonged beep informs the operator that the control panel **8** is starting up.
  - › Wait until the MDB logo disappears from the display **9**.
- › Turn ignition key **4** to START position.
  - › The engine starts.
- › Release the ignition key **4**, which will return to the ON position.
  - › Necessary condition for proper functioning of the hydraulic system.

## WARNING

The starting operation must be repeated for a maximum of twenty consecutive seconds. If the engine does not start, wait one minute before repeating the starting operation.

If the engine does not start after two attempts, contact MDB service..

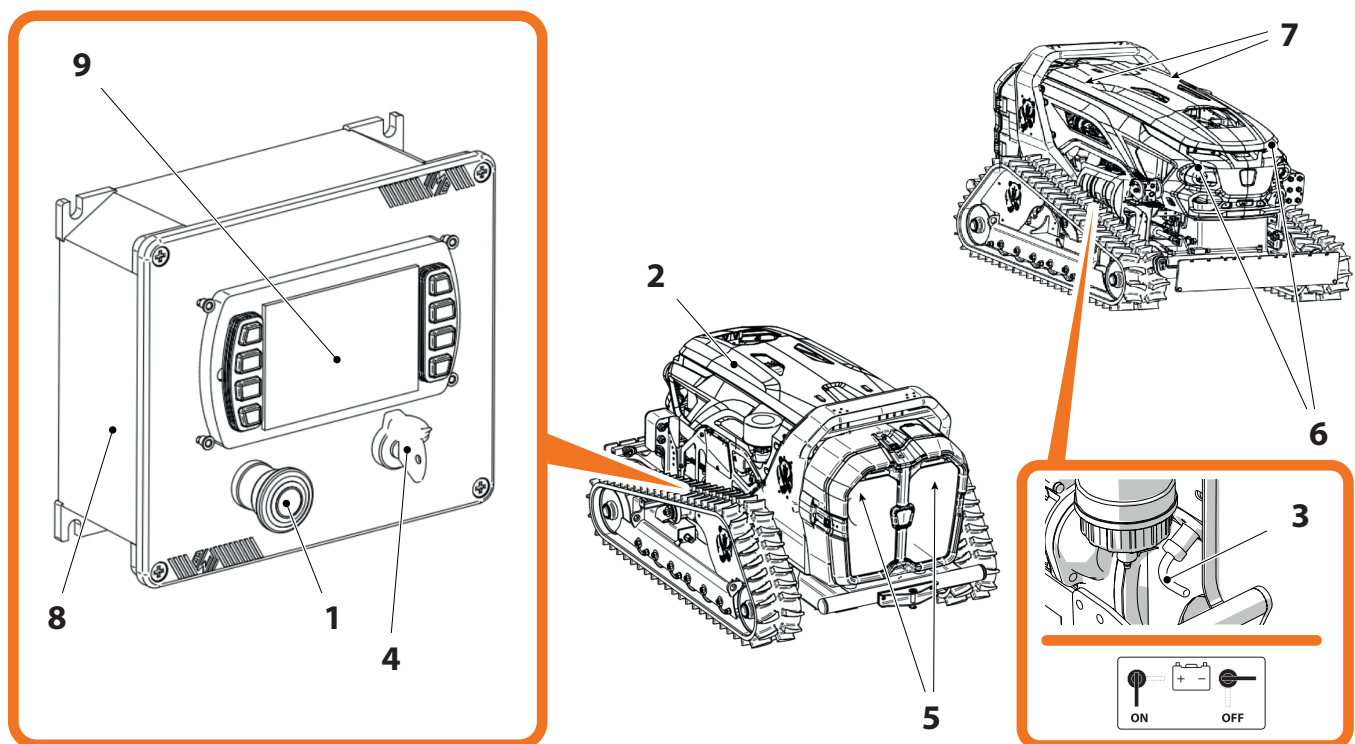



### 5.5.2 STARTING WITH RADIO CONTROL

Proceed as follows.

- › Ensure that the emergency buttons **1** are not pressed.
- › Open the bonnet **2** (as described in Chapter 6).
- › Insert the "battery cut-off" key **3**, and turn it to the ON position.
- › Close bonnet **2**.
- › Insert ignition key **4** and turn it to the ON position.
  - › Red lights **5** come on steady, white lights **6** come on steady, yellow lights **7** come on flashing.
  - › A prolonged beep informs the operator that the control panel **8** is starting up.
  - › Wait until the MDB logo disappears from the display **9**.
- › Press the **S10** button on the radio control to switch on the radio control.
  - › The **TX** indicator light will flash and after a few seconds the **RX** indicator light will also start flashing.
- › Press the **S10** button again to confirm.
  - › Once the connection operation is confirmed, the **TX** and **RX** LEDs remain lit steadily.
- › Press the engine start button **S18**.
  - › The engine starts.

## WARNING

The starting operation must be repeated for a maximum of twenty consecutive seconds. If the engine does not start, wait one minute before repeating the starting operation.

If the engine does not start after two attempts, contact MDB service.

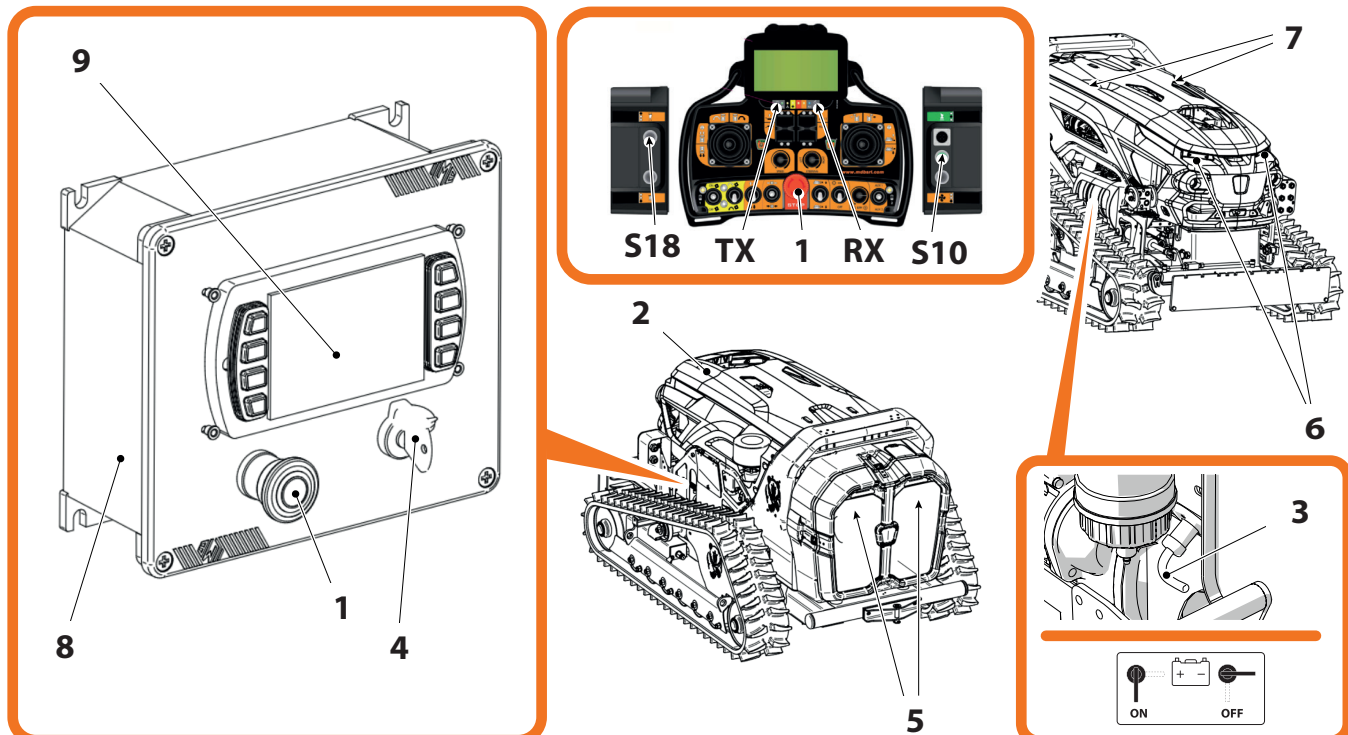

**5.6 USE****WARNING**

The procedures described below are intended to illustrate the main controls necessary for the correct operation of the machine.

In order to be able to carry out operations correctly and safely, the following procedures must be fully understood.

**5.6.1 MAIN COMMANDS**

The machine's main controls are listed below.

- › Operate lever **J1** in the direction indicated by the arrow to steer to the right.

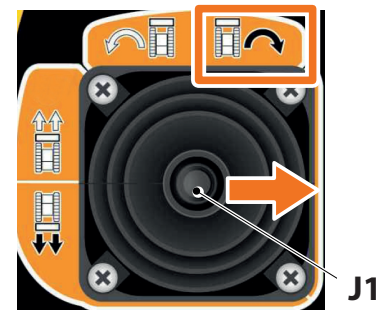

- › Operate lever **J1** in the direction indicated by the arrow, to steer to the left.

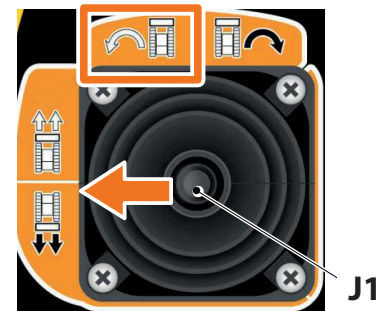

- › Operate lever **J1** in the direction indicated by the arrow, to execute forward movement of the machine.

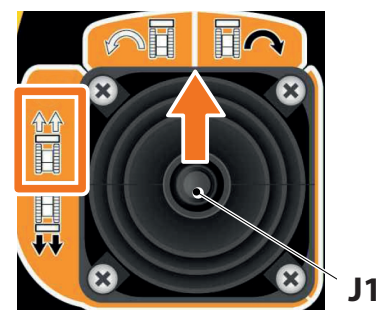

- › Operate lever **J1** in the direction indicated by the arrow, to execute backward movement of the machine.





With the remote control:

- › Operate lever J4 in the direction indicated by the arrow to move the implement to the left.

With on-board controls:

- › Operate lever 3 in the direction indicated by the arrow to move the implement to the left.

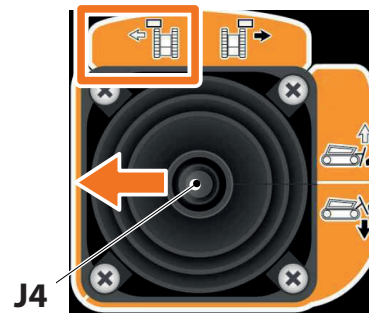
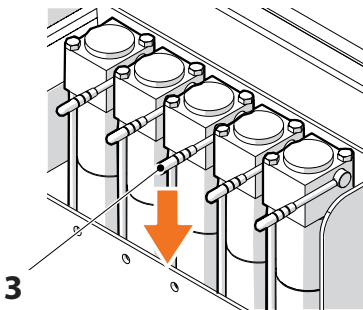

With the radio remote control:

- › Operate lever J4 in the direction indicated by the arrow to move the implement to the right.

With on-board controls:

- › Operate lever 3 in the direction indicated by the arrow to move the implement to the right.

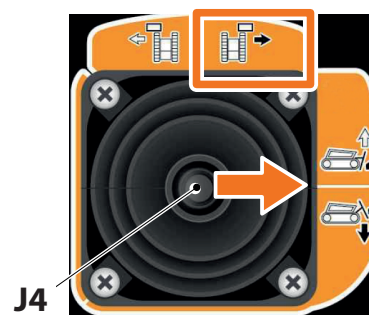
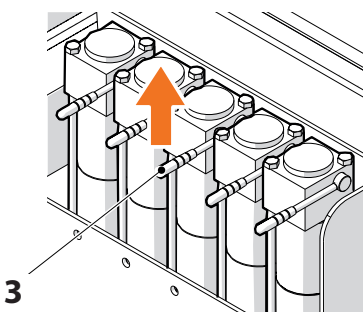

With the radio control:

- › Operate lever J4 in the direction indicated by the arrow to move the implement upwards.

With on-board controls:

- › Operate lever 2 in the direction indicated by the arrow to move the implement upwards.

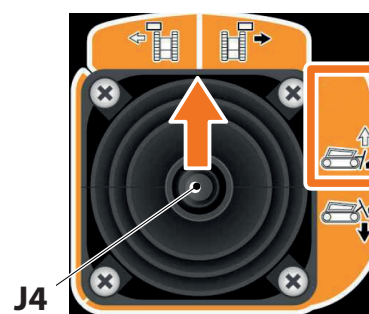
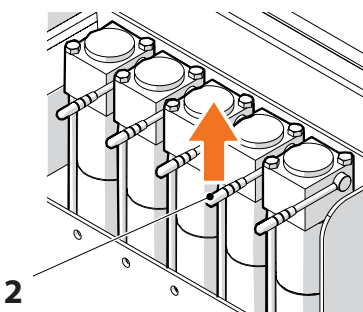

With the radio control:

- › Operate lever J4 in the direction indicated by the arrow to move the implement downwards.

With on-board controls:

- › Operate lever 2 in the direction indicated by the arrow to move the implement downwards.

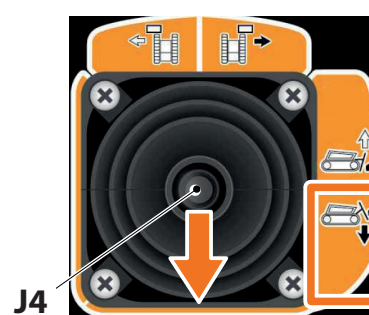
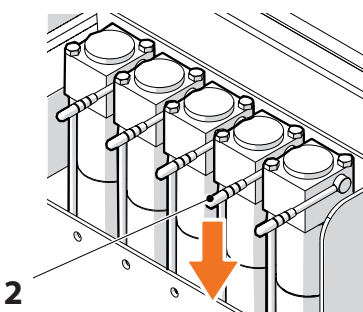

With the radio remote control:

- › Operate lever S6 in the direction indicated by the arrow, to perform track widening.

With on-board controls:

- › Operate lever 1 in the direction indicated by the arrow, to perform track widening.

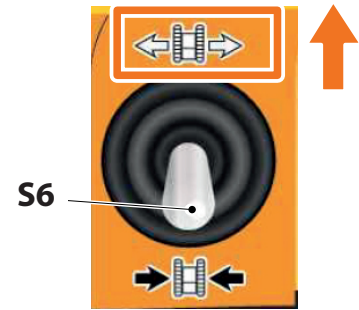
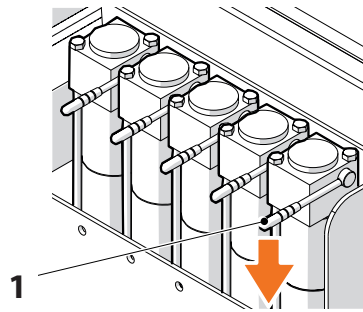

With the radio remote control:

- › Operate lever S6 in the direction indicated by the arrow, to perform track shrinkage.

With on-board controls:

- › Operate lever 1 in the direction indicated by the arrow, to execute track shrinkage.

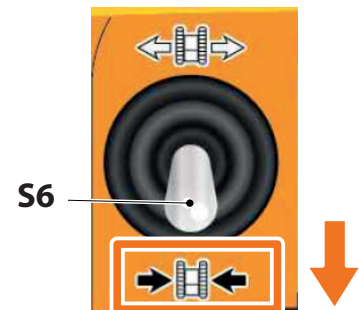
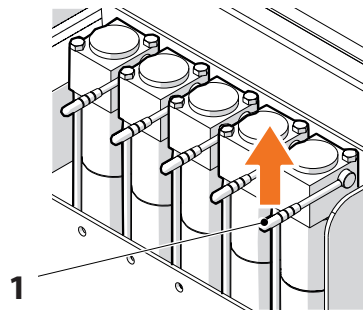

## WARNING

For the working and machine movement configurations, which can be realised with the above-mentioned commands, please refer to section '3.6 Machine Configurations'.

- › Operate selector switch **S4** in the direction indicated by the arrow to activate the semi-floating movement of the implement.
  - › In the semi-floating movement, the implement rises from the ground to the height set with lever J4.



- › Operate selector switch **S4** in the direction indicated by the arrow to activate the floating movement of the tool.
  - › In the floating movement, the implement follows the contour of the ground.





- › Turn knob **S3** in the direction indicated by the arrow, to increase the engine speed.

- › Adjust the engine revs according to the work to be done.

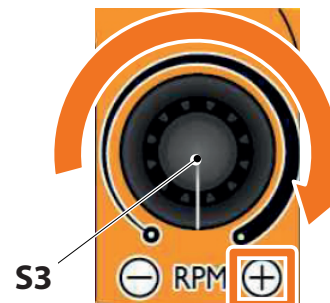

- › Turn the **S3** knob in the direction indicated by the arrow, to decrease the engine speed.

- › Adjust the engine revs, depending on the work to be done.

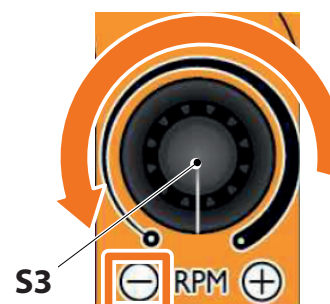

- › Operate selector switch **S7** in the direction indicated by the arrow to leave the controls of J1 unchanged.

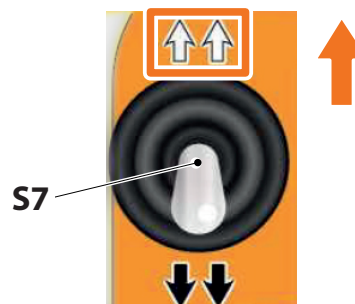

- › Operate selector switch **S7** in the direction indicated by the arrow to reverse the commands of J1.

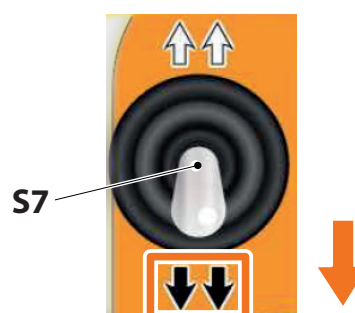



- › The adjustment allows the machine to always move in line with the direction of travel, enabling the operator to correct (when necessary and depending on the working conditions), the traction of the individual tracks
- › The adjustment allows the alignment between the trajectory travelled by the machine and the axis of the machine itself. Once the path has been completed, simply return the knob to its initial position.
- › If the working surface does not influence the machine's course, the machine's axis of travel (parallel to the tracks) will correspond to the machine's line of travel, and it will not be necessary to use this adjustment.

› Turn knob **S8** in the direction indicated by the arrow to correct the machine's trajectory to the right.



› Turn knob **S8** in the direction indicated by the arrow to correct the machine's trajectory to the left.



- › Turn knob **S9** in the direction indicated by the arrow, to increase the speed of the machine.



- › Turn knob **S9** in the direction indicated by the arrow, to decrease the speed of the machine.





- › Operate selector switch **S1** in the direction indicated by the arrow (ON), to switch the lights on.
- › Operate **S1** in the direction indicated by the arrow (OFF), to switch off the lights.



- › Press the **S11** button to operate the radiator cleaning fan.
- › Release the **S11** button to operate the radiator cleaning fan.

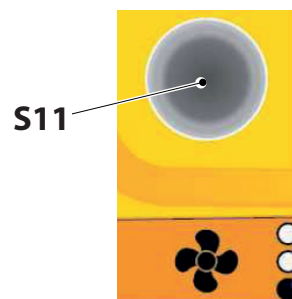

## WARNING

Refer to Chapter 6 for cleaning schedules.



### 5.6.2 SAFETY RULES FOR USE



#### **DANGER**

During use, there must be no persons in the working area of the machine, as stated in section '3.4 Working Area'.



#### **CAUTION**

Gradually operate the relevant controls (refer to section "5.2.1 Description of the radio control" and/or section "5.3 Machine controls") in order to achieve a slow and steady ascent/descent and a jolt-free stop.



#### **DANGER**

Avoid abrupt starts, braking and steering.

#### **WARNING**

Use the horn to warn any persons in the work area.

### 5.6.3 USE

#### **WARNING**

The use of the machine varies depending on the type of implement installed on it.

Therefore, for information on the use of the machine, refer to the manual of the implement that is installed on it.



#### **CAUTION**

Do not stop the machine at work or transit areas.



#### **CAUTION**

Gradually actuate the relevant controls (refer to section "5.2.1 Description of the radio control" and/or section "5.3 Machine controls") in order to achieve smooth and constant working, and a jolt-free stop.



## 5.7 PARKING

Proceed as follows:

- › Identify the machine's parking area.
- › Move the machine, bringing it to the prepared zone (use the controls indicated in the previous paragraphs).
- › If the tracks are in a widened position, proceed to narrow them (use the commands indicated in the previous paragraphs), moving the machine to working and handling configuration 1, as indicated in paragraph "3.6 Machine configurations"..

### WARNING

If it is necessary to dismantle the tool installed on the machine, proceed as indicated in the manual of the tool being installed on the machine.

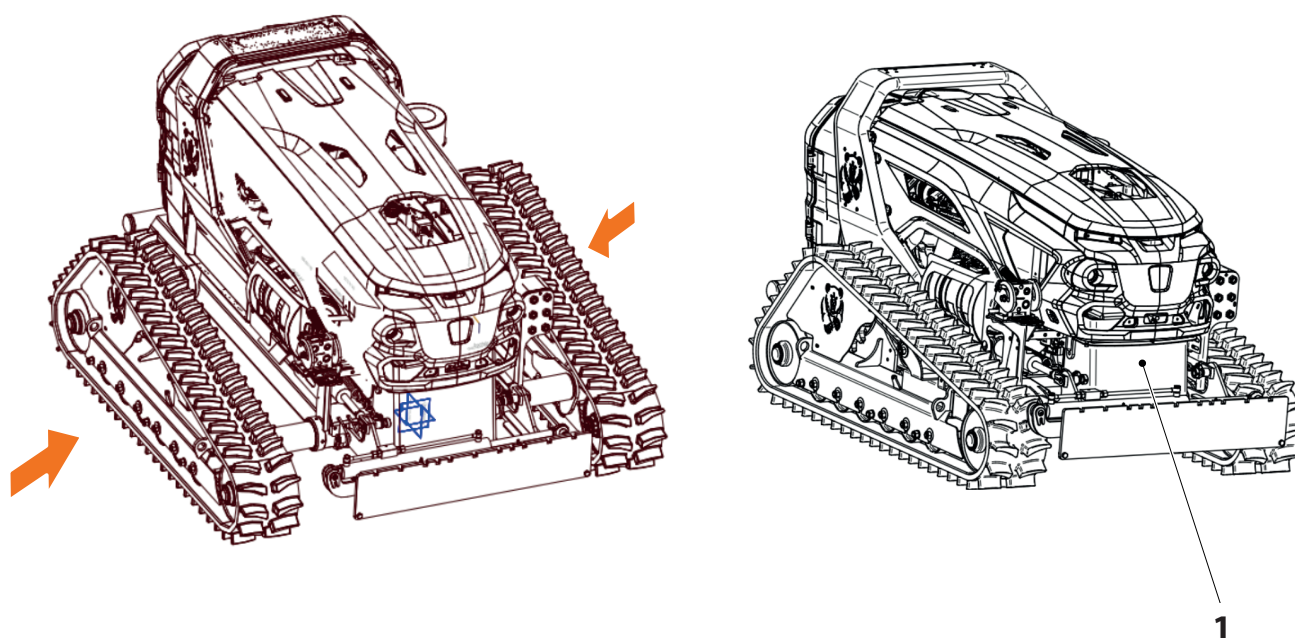



## 5.8 STOP

Stopping the machine is possible in two distinct ways:

- › Manual stop
- › Stop with remote control

### WARNING

The operator at the end of the work shift must check for leaks of liquids (fuel, coolant, hydraulic oil).

### 5.8.1 MANUAL STOP

Proceed as follows.

- › Turn ignition key **1** to the OFF position.
  - › The motor stops.
  - › Display **2** goes out.
  - › Red lights **3** switch off, white lights **4** switch off, yellow lights **5** switch off.
- › Remove the ignition key **1**, and hand it over to your supervisor.
- › Open the bonnet **6** (as described in Chapter 6).
- › Turn the battery cut-off key **7** to the OFF position.
- › Switch off the "battery cut-off" key **7**.
- › Close bonnet **6**.

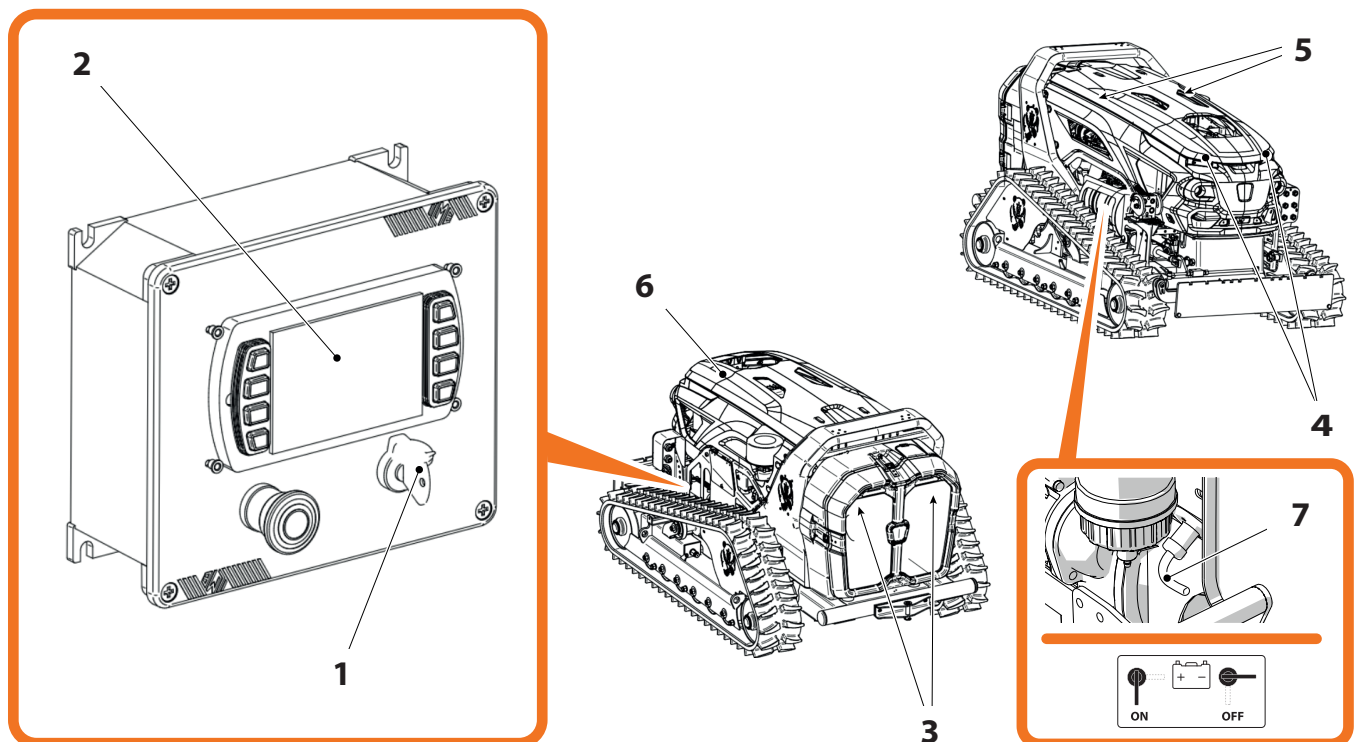



### 5.8.2 STOP WITH RADIO CONTROL

Proceed as follows.

- › Press the engine shutdown button **S16**.
  - › The engine stops.
- › Press the **S5** button on the remote control, to switch off the remote control.
  - › **TX** and **RX** LEDs go out.
- › Turn ignition key **1** to OFF position.
  - › Display **2** goes off.
  - › Red lights **3** go out, white lights **4** go out, yellow lights **5** go out.
- › Remove the ignition key **1**, and hand it over to your supervisor.
- › Open the bonnet **6** (as described in Chapter 6).
- › Turn the battery cut-off key **7** to the OFF position.
- › Switch off the "battery cut-off" key 7.
- › Close bonnet **6**.
- › Place the radio remote control in its case.

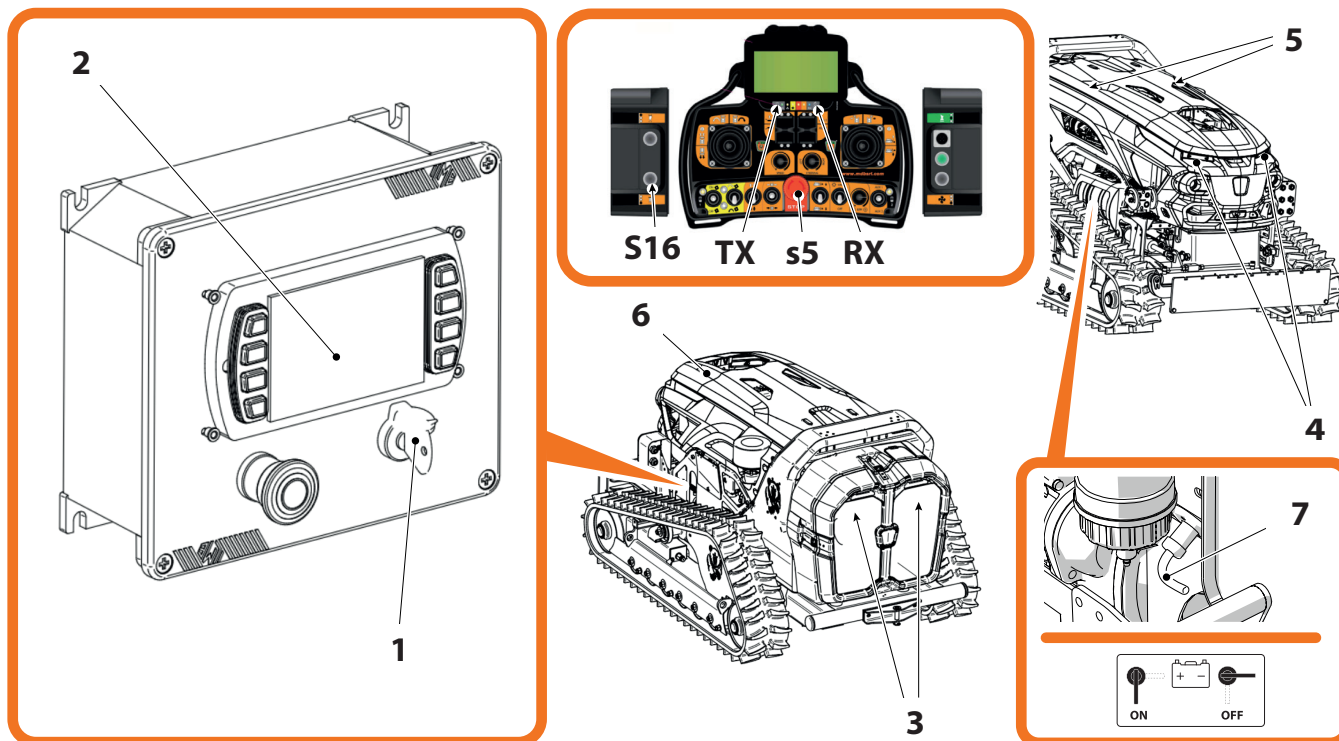



### 5.9 HYDRAULIC CONNECTION OF OPTIONAL TOOLS

The machine has the possibility of installing optional implements applicable to various types of use. These implements must be hydraulically connected to the machine, via the AUX A-B and AUX C-D connections, and are controlled via the radio control and/or on-board machine controls, as indicated in paragraph "5.2 Radio control" and paragraph "5.3 On-board machine controls".

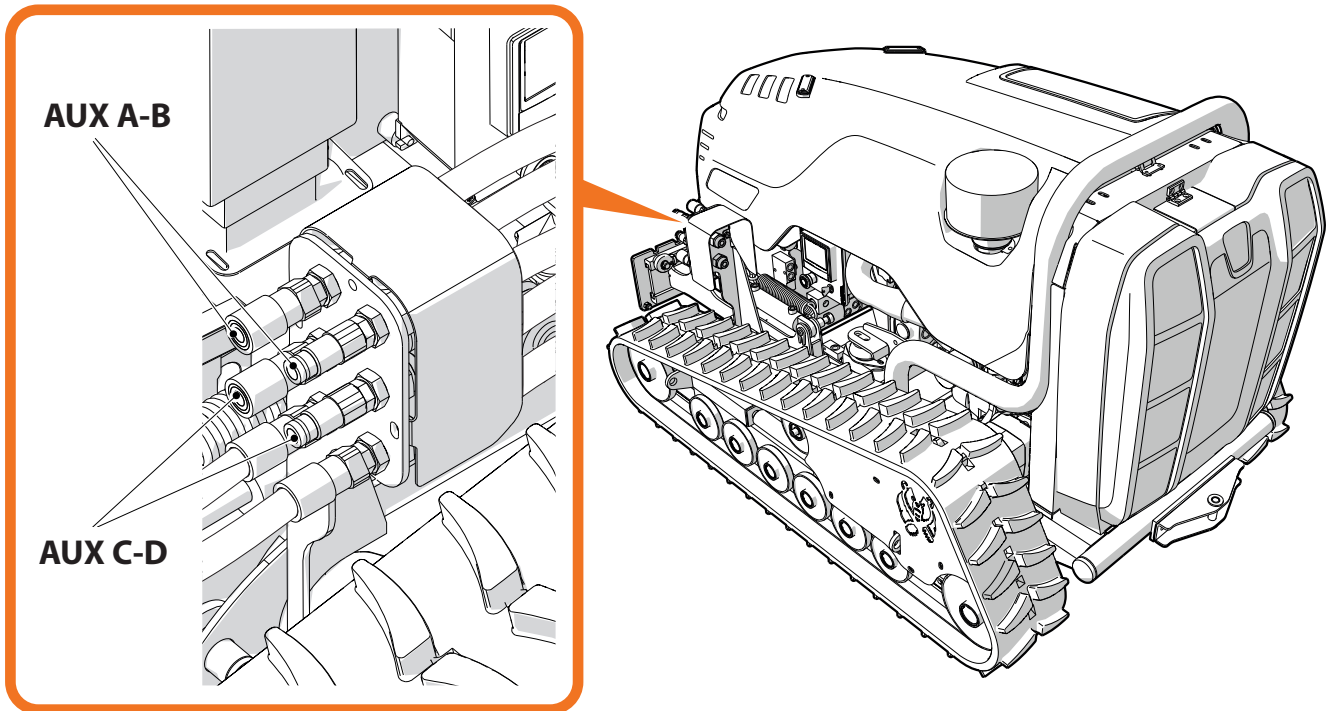



# ***MDB***





## 6 MAINTENANCE

Correct maintenance is a decisive factor for the long life of the machine.

All maintenance operations must be carried out according to the instructions in this manual, and in compliance with the laws in force in the country where the machine is used.

MDB accepts no responsibility for damage caused to the machine or accidents caused by incorrect maintenance.

If parts have to be replaced, they must be original MDB spare parts only.

MDB accepts no liability for damage to the machine or accidents caused by the use of non-original spare parts.

The use of non-original spare parts immediately invalidates the warranty..

Maintenance operations are divided into:

- › Routine maintenance (the responsibility of the end user's maintenance technicians).
- › Extraordinary maintenance (the responsibility of MDB's specialist technicians or personnel authorised by MDB).

### 6.1 PREPARING TO PERFORM MAINTENANCE

To carry out maintenance, the machine must be set up in the following condition:

- › If a tool is installed on the machine, proceed to disassemble it and park it (refer to the manual of the tool being installed on the machine).
- › Place the machine on a horizontal surface.
- › Place the machine's tracks in the maximum extension configuration (refer to chapter 3 and chapter 5).
- › Turn the "battery cut-off" key to the OFF position and switch it off (refer to chapter 5)..
  - › To access the 'battery cut-off' key area, the bonnet must be opened, as described in the next paragraph.
- › Place a sign on the control panel stating 'Do not use'.
- › Bar access to the area around the machine to all unauthorised persons.

**Unless otherwise specified, carry out maintenance operations when the engine is cold.**



**DANGER**

**Before starting any maintenance, make sure that the ignition key is not inserted in the control panel and if it is, remove it and hand it over to the person in charge of the machine.**

**During maintenance operations, any tool installed on the machine must absolutely be removed (for the procedure refer to the manual of the tool installed on the machine).**

**WARNING**

**Unless otherwise specified, carry out maintenance operations by placing the machine on a horizontal plane.**



### 6.1.1 ENGINE COMPARTMENT BONNET

Certain types of maintenance require the bonnet **1** to be opened.

To open the first bonnet, lever **1** must be operated, and to open the second bonnet, lever **2** must be operated.

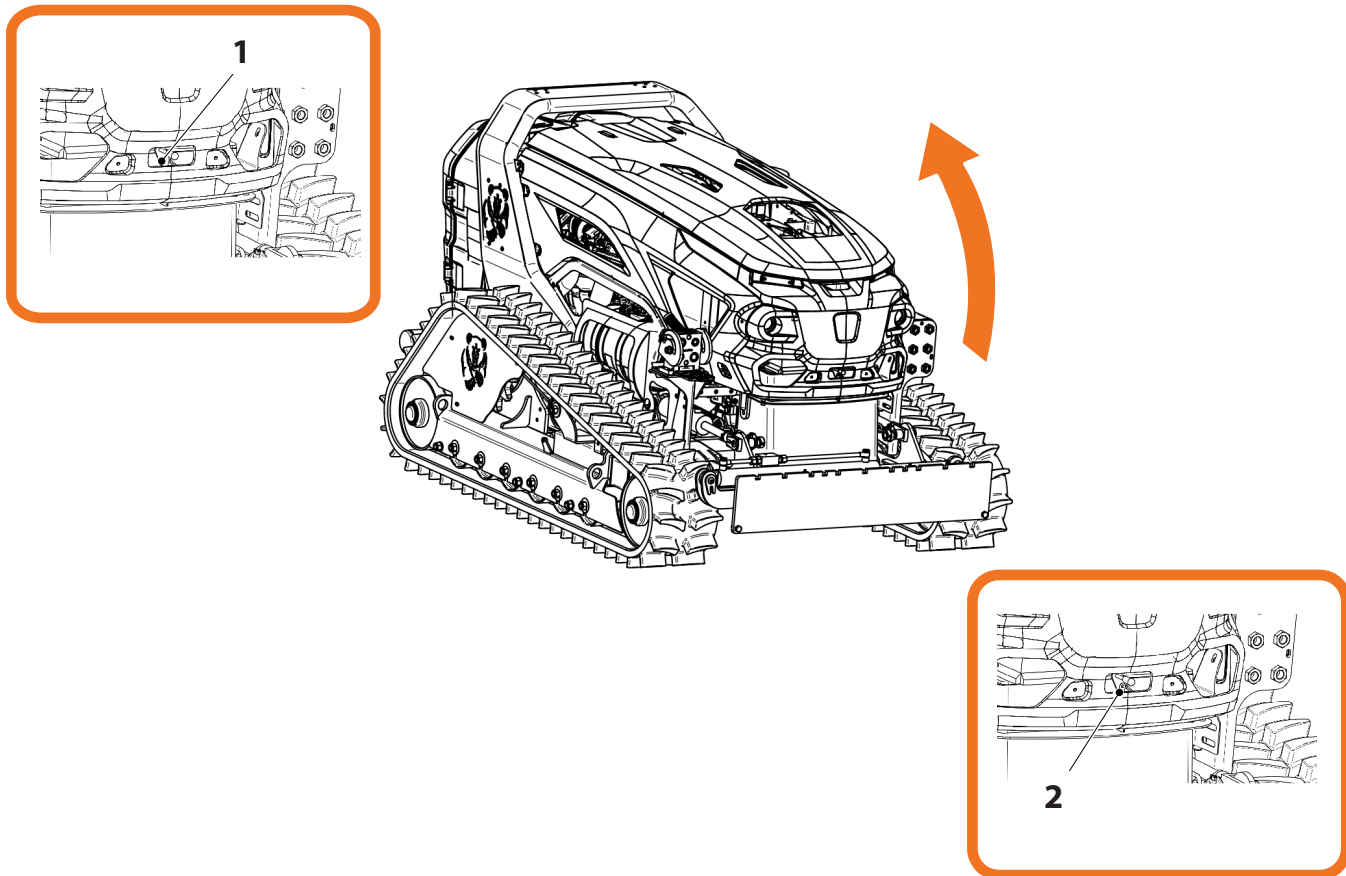

### 6.2 EQUIPMENT PROVIDED

MDB provides the following equipment:

- › Grease pump
- › Hose for grease pump
- › Fitting for track tensioner
- › Connector for grease nipple
- › Grease (for type of grease refer to chapter 3)
- › Spare fuse kit
- › Fuse pliers

## WARNING

**All maintenance equipment not expressly mentioned above is not supplied by MDB, but is the responsibility of the end user.**



### 6.3 SCHEDULED MAINTENANCE TABLE

Below is the information required to determine when the machine needs maintenance.

Carry out maintenance work on time, according to the indications of the hour counter (refer to chapter 5) and following the table below.

Timing (Hours)	Type of maintenance	Reference to paragraph
10	General cleaning of the machine	6.4.2
10	Radiator cleaning	6.4.3
10	Engine oil check	6.4.4
10	Check coolant	6.4.7
10	Check hydraulic oil level	6.4.10
10	Check air filters	6.4.13
10	Check separator filter	6.4.14
10	Check separator filter	6.4.18
10	Check and tension tracks	6.4.24
10	Periodic lubrication	6.4.25
10	Check clamping elements	6.4.26
10	Check cooling system	6.4.28
10	Check hydraulic system	6.4.29
10	Electrical system check	6.4.30
40	General checks	6.4.1
50	Change engine oil and oil filter	6.4.6
50	Change separator filter	6.4.20
160	Check hydraulic oil filter	6.4.16
200	Change engine oil and oil filter	6.4.6
250	Check POLY-V alternator belt	6.4.19
250	Replace fuel filter	6.4.21
500	Check working elements	6.4.27
1000	Check, top up and replace hydraulic oil	6.4.8
1000	Replace air filters	6.4.11
1000	Change hydraulic oil	6.4.12
1000	Change air filters	6.4.15
1000	Change hydraulic oil filter	6.4.17
4000	Change coolant	6.4.9



<b>Timing (Hours)</b>	<b>Type of maintenance</b>	<b>Reference to paragraph</b>
<b>6000</b>	Particle filter cleaning	<b>6.4.22</b>
<b>9000</b>	Particulate filter replacement	<b>6.4.23</b>
	Check cooling system	<b>6.4.30</b>
	Check hydraulic system	<b>6.4.31</b>



6.3.1 CHECKLIST









Symbols used	
Description	Symbol
Generic indication	•
Functional test	
Replacement	
Visual check	
Screw tightness check	
Cleaning	

Type of maintenance	Maintenance interval										
	8	40	50	160	200	250	500	1000	4000	6000	9000
General cleaning of the machine											
Radiator cleaning											
Engine oil check											
Check coolant											
Check hydraulic oil level											
Check air filters											



Type of maintenance	Maintenance interval											
	8	40	50	160	200	250	500	1000	4000	6000	9000	
Rubber hose check												
Filter separator check												
Checking and tensioning tracks												
Periodic lubrication	•											
Check clamping elements												
Check cooling system												
Check hydraulic system												
Electrical system check	 											
General checks												
Change engine oil and oil filter												
Change separator filter												
Check hydraulic oil filter												



Type of maintenance	Maintenance interval										
	8	40	50	160	200	250	500	1000	4000	6000	9000
Change engine oil and oil filter											
Change fuel filter											
Check working elements											
Change hydraulic oil											
Change air filters											
Replace hydraulic oil filter											
Change coolant											
Clean particle filter											
Replace particle filter											



## 6.4 ROUTINE MAINTENANCE

Maintenance must only be carried out by a qualified and authorised person, called the maintenance technician.

### WARNING

The maintenance technician must have sufficient competence and experience to be able to assess the condition of the machine and the effectiveness of personal protective equipment, based on technical conventions.

Routine maintenance is the responsibility of the end user's maintenance technician.

### 6.4.1 GENERAL CHECKS I

Every 40 working hours, carry out a general check of the machine's integrity.

### 6.4.2 GENERAL MACHINE CLEANING

Every 8 working hours, thoroughly clean the machine of any mud and debris.

The cleaning method can be:

- › Manual (Use a soft cloth moistened with water, and/or environmentally friendly detergents)
- › Assisted (Use a high-pressure water cleaning device)

### WARNING

Use only environmentally friendly, pH-neutral cleaning agents for cleaning.  
Do not use cleaning devices that can scratch or scrape.

## USING A HIGH-PRESSURE WATER CLEANING DEVICE



### CAUTION

If the following instructions are not followed, damage to the machine may occur.

- › The temperature of the water and cleaning agent must never exceed 60 degrees centigrade.
- › The correct distance between the nozzle of the cleaning equipment and the machine must always be ensured. This is to avoid damaging the parts being washed.
- › The water jet must never be directed in the direction of:
  - › Electrical and Electronic Components
  - › Plastic Components
  - › Bearings
  - › Support points
  - › Signs and stickers

### 6.4.3 RADIATOR CLEANING

Every 8 working hours proceed with the above-mentioned cleaning.



## CAUTION

### BURN HAZARD

The operator must wear the following personal protective equipment:



- › Safety footwear
- › Burn-proof gloves
- › Protective clothing
- › Protective goggles

Proceed as follows:

- › Unlock tie rods **1** and open crankcase **2**, turning it in the direction indicated by the arrow.
- › Press button **S11** to activate the radiator cleaning fan.

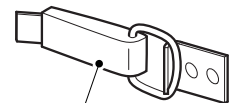
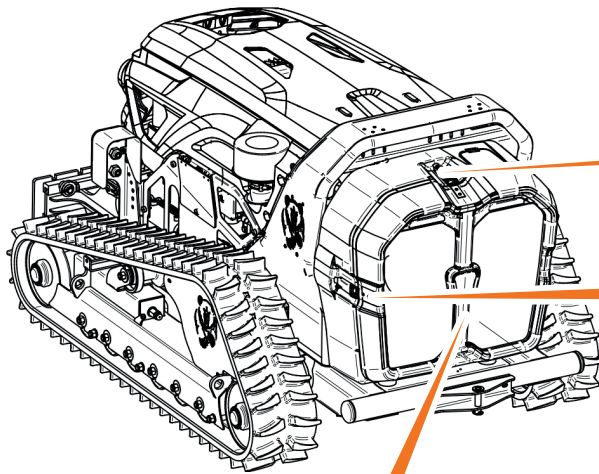

**1**

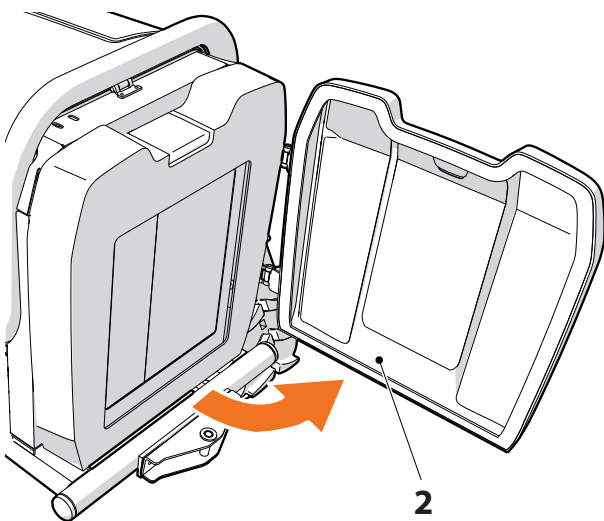

**2**



**S11**



#### 6.4.4 ENGINE OIL CHECK

Every 8 working hours carry out the above-mentioned check.



### CAUTION

#### BURN HAZARD



The operator must wear the following personal protective equipment:

- › Safety footwear
- › Burn-proof gloves
- › Protective clothing
- › Protective goggles

Proceed as follows:

- › Visually check the oil level by means of the oil dipstick.
- › If the oil is below the minimum level, proceed as indicated in the next paragraph.

#### 6.4.5 REFILLING ENGINE OIL

### WARNING

For the type of product used refer to section "3.3.4 Other technical specifications".

For the quantity of product used refer to Annex B.

Proceed as follows:

- › Top up the oil as indicated in Annex B.

#### 6.4.6 CHANGING ENGINE OIL AND OIL FILTER

After the first 50 working hours, proceed with the above-mentioned replacement.

Every 200 working hours thereafter, proceed with the above-mentioned replacement.

### WARNING

This operation is reserved for technicians at an MDB service centre. For this reason, please contact the MDB service centre (see chapter 2).

### 6.4.7 LEVEL CHECK, TOPPING UP COOLANT

Every 10 working hours, carry out the above-mentioned check.

#### **AVVERTENZA**

#### **BURN HAZARD**



**The operator must wear the following personal protective equipment:**

- › Safety footwear
- › Burn-proof gloves
- › Protective clothing
- › Protective goggles

Checking and topping up the coolant level must be carried out with the vehicle not on an incline and with the engine stopped and cold.

Proceed as follows:

- › Locate the radiator cap, located at the rear of the car.



- › Lift the lid.

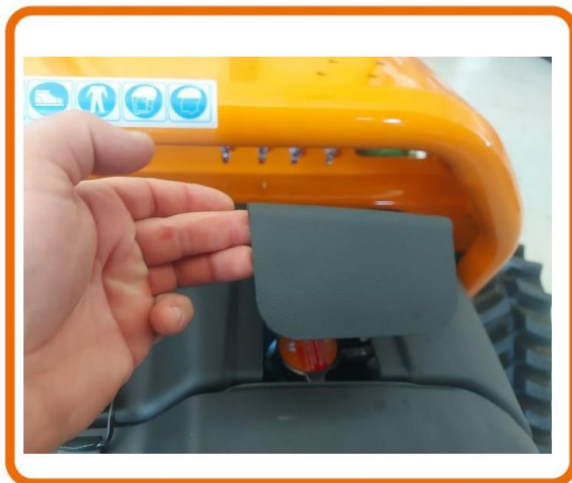

- › For simple topping up, unscrew the cap and pour in coolant until the maximum level is reached.
- › Screw the cap back on.

**CAUTION**

If a leak in the cooling circuit is detected or the liquid level is too low, do not continue to use the machine. Find the cause and repair the fault immediately before starting to use the machine again.

**CAUTION**

The coolant must consist of: 50% ANTIFREEZE and 50% decalcified water.

**CAUTION**

The liquid must cover the pipes inside the radiator by about 5 mm. Do not fill the radiator completely, but leave an adequate free volume for expansion of the coolant.

### 6.4.8 HYDRAULIC OIL LEVEL CHECK, TOPPING UP AND REPLACEMENT

Every 1000 working hours proceed with the above-mentioned replacement.



## CAUTION



**The operator must wear the following personal protective equipment:**

- › Protective clothing
- › Safety footwear

Refuelling and checking the hydraulic oil level must be carried out with the vehicle not on an incline and with the engine stopped. Proceed as follows

- › Raise the bonnet of the machine by operating the lever.



- › Once the reservoir and hydraulic oil cap are located, for simple topping up, remove the cap and pour in the oil; during this operation, check the maximum level indicator on the right side of the machine.

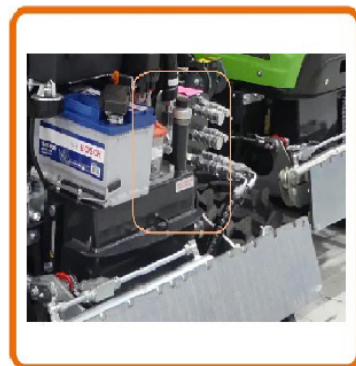

- › Screw the cap back on.



For a complete hydraulic oil change, it is recommended that the tank be emptied with the engine warm, but switched off, in order to obtain rapid and complete draining of the oil.

**CAUTION**

**Always wear protective gloves to protect the skin when carrying out these operations. To choose the correct type of gloves, consult the safety data sheet of the oil you are using. The manufacturer recommends the use of AGIP OSO 46 oil.**

**CAUTION**

**Do not dispose of used oil in the environment as it is highly polluting. Before restarting, make sure that the drain plug and filler cap are screwed on properly to prevent lubricant spillage.**

### 6.4.9 REPLACING AIR FILTER CARTRIDGE

Every 500 working hours, carry out the above-mentioned check.



## CAUTION



**The operator must wear the following personal protective equipment:**

- > Safety footwear
- > Gloves
- > Protective clothing
- > Protective goggles

Proceed as follows:

- > Release the two hooks **F** of cover **A**.
- > Pull out cartridges **B** and **G**.
- > Reassemble:
  - > the new cartridges **B** and **G**.
  - > the cover **A** by verifying the correct tightness of the hooks **F**.

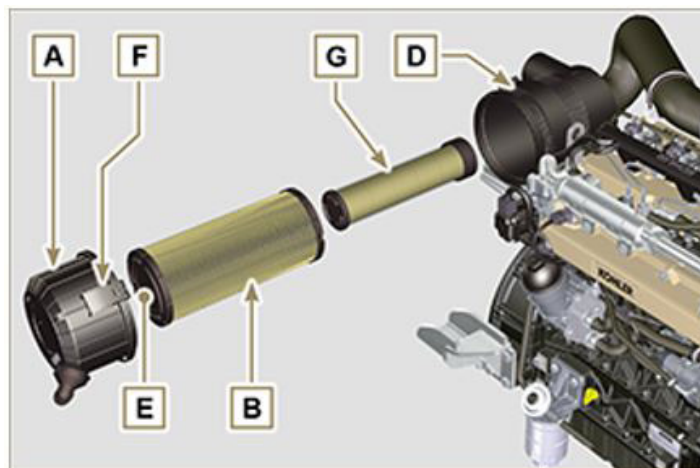



### 6.4.10 AIR FILTER CLEANING

Proceed as follows:

- › Unlock the latches **1**.
- › Remove external filter **2** and internal filter **3**.
- › Move to a room with a dust extraction system.
- › Clean external filter **2** and internal filter **3** using a compressed air jet.
- › Direct the compressed air jet from inside the filters to the outside of the filters.

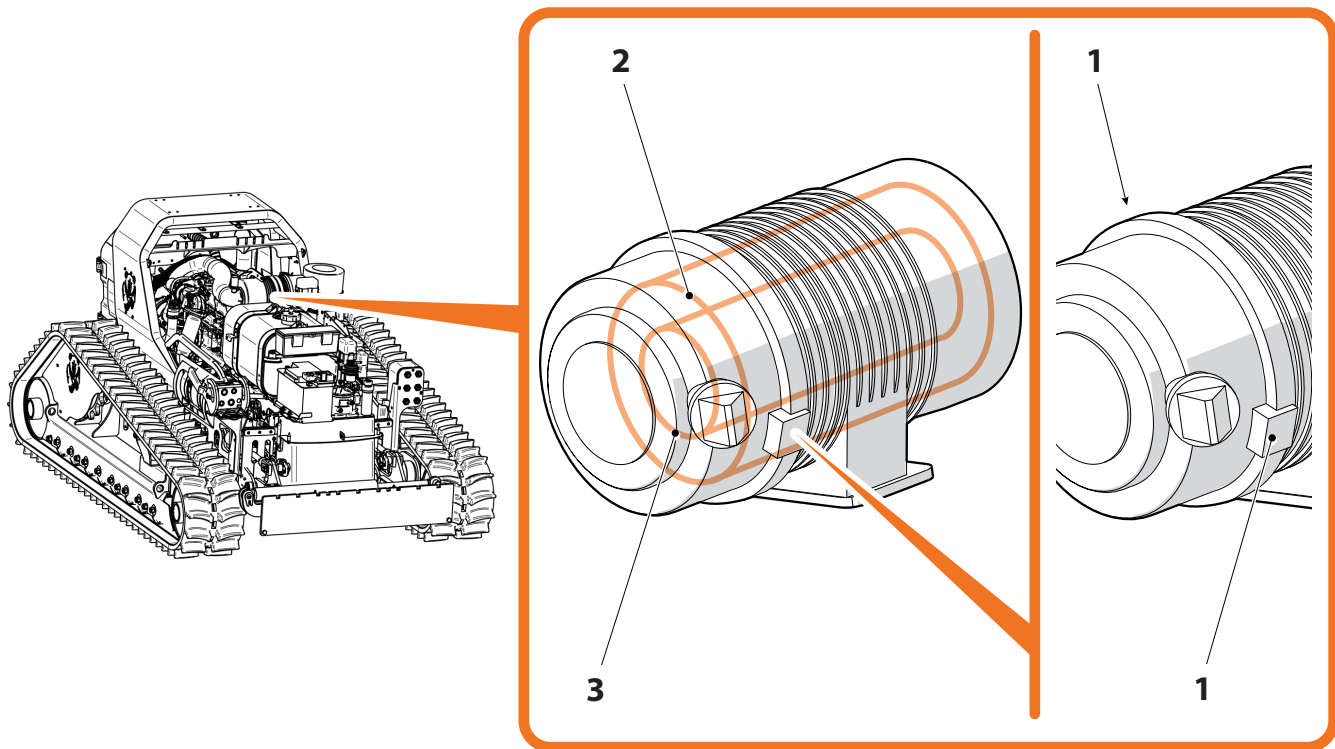

### 6.4.11 CHANGING AIR FILTERS

Every 1000 working hours proceed with the above-mentioned replacement.

## WARNING

This operation is reserved for technicians at an MDB service centre. For this reason, please contact the MDB service centre (see chapter 2).

### 6.4.12 HYDRAULIC OIL FILTER CHECK

Every 160 working hours carry out the above-mentioned check.



## CAUTION



**The operator must wear the following personal protective equipment:**

- › Safety footwear
- › Gloves
- › Protective clothing
- › Protective goggle



## DANGER

**This operation must be carried out only when the engine is cold.**

Proceed as follows:

- › Open the bonnet (refer to section "6.1.1 Engine compartment bonnet").
- › Insert a hexagonal key in the square section block **1** of cap **2**.
- › Unscrew cap **2** and remove it.
- › Pull out the filter **3**.
- › Visually check the level of cleanliness of the filter **3**.
- › If the filter is dirty, proceed as indicated in the next paragraph.

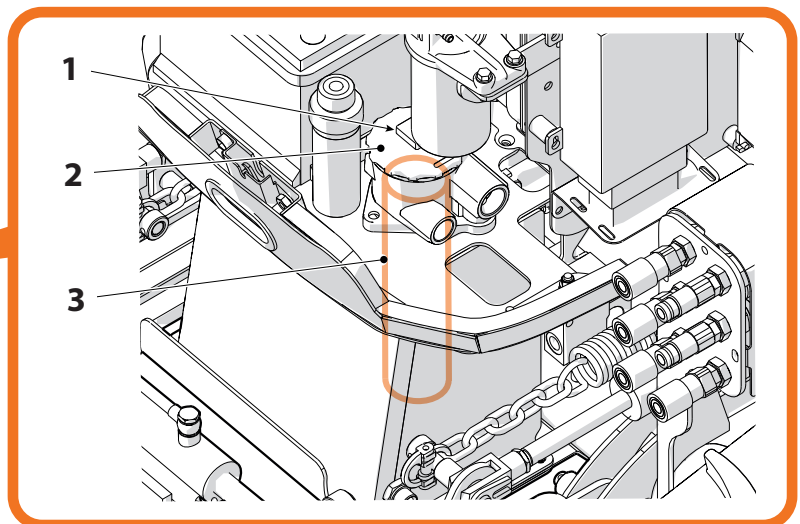
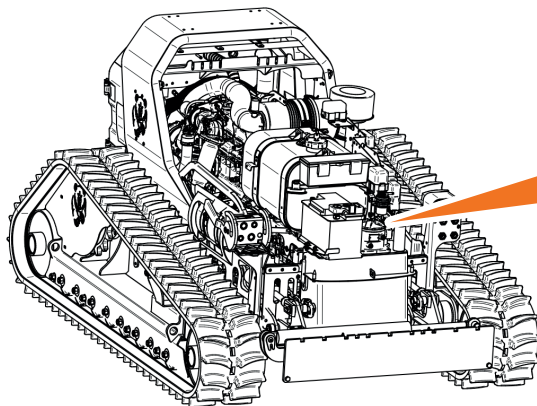

### 6.4.13 REPLACING THE HYDRAULIC OIL FILTER

Every 1000 working hours proceed with the above-mentioned replacement.

## WARNING

**This operation is reserved for technicians at an MDB service centre. For this reason, please contact the MDB service centre (see chapter 2).**



#### 6.4.14 FILTER SEPARATOR CONTROL

Every 8 working hours carry out the above-mentioned check.



### CAUTION

#### BURN HAZARD

The operator must wear the following personal protective equipment:



- › Safety footwear
- › Gloves
- › Protective clothing
- › Protective goggle

Proceed as follows:

- › Open the bonnet (refer to section "6.1.1 Engine compartment bonnet").
- › Identify the separator filter **1**.
- › If the filter is dirty, proceed as indicated in the next paragraph.

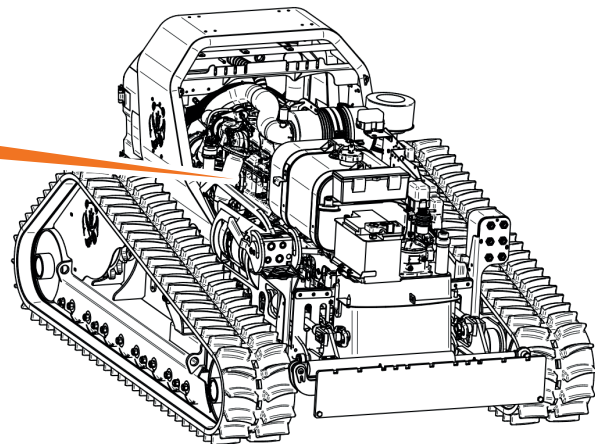
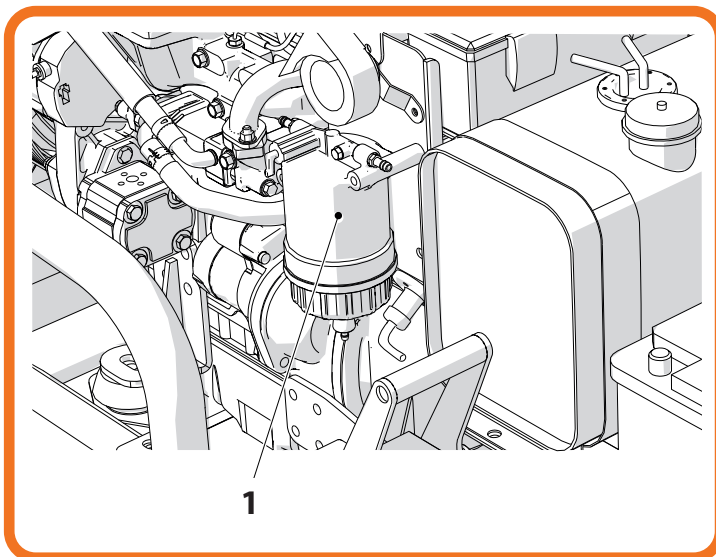

#### 6.4.15 FILTER SEPARATOR CLEANING

Proceed as follows:

- › Clean the filter as shown in Annex B.

#### 6.4.16 FILTER SEPARATOR REPLACEMENT

Every 50 working hours proceed with the above-mentioned replacement.

### WARNING

This operation is reserved for technicians at an MDB service centre. For this reason, please contact the MDB service centre (see chapter 2).

### 6.4.17 REPLACEMENT OF FUEL CARTRIDGE AND PREFILTER

Every 250 working hours proceed with the above-mentioned replacement.

## WARNING

This operation is reserved for technicians at an MDB service centre. For this reason, please contact the MDB service centre (see chapter 2).



## CAUTION

### BURN HAZARD



The operator must wear the following personal protective equipment:

- > Safety footwear
- > Gloves
- > Protective clothing
- > Protective goggle

Proceed as follows:

- > Disconnect cable **A** of water detector **C**.
- > Unscrew water detector **C** from cartridge **B**.
- > Unscrew cartridge **B** with spanner **F**.
- > Oil seal **D** of new cartridge **B**.



## CAUTION

Do not fill new cartridge **B** with fuel.

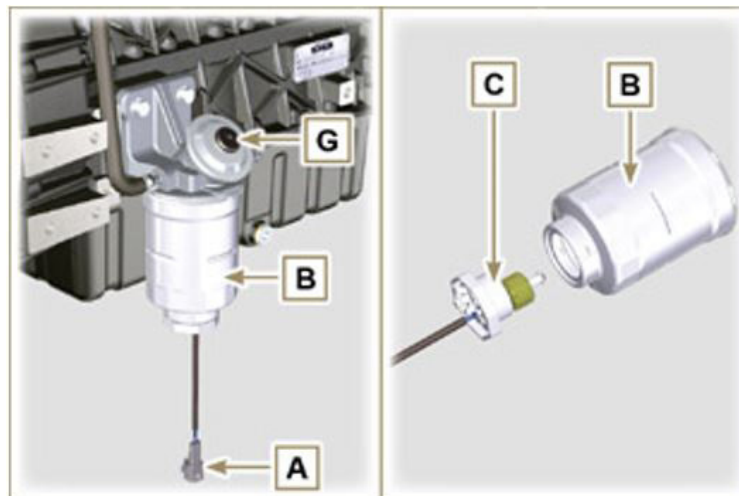



- › Screw the new cartridge **B** onto the oil filter holder **E** with the appropriate spanner **F** (tightening torque to 17 Nm).
- › Screw the water detector **C** onto the new cartridge **B** (tightening torque to 5 Nm).
- › Reconnect cable **A** of the water detector.
- › Press button **G** several times to fill the circuit.

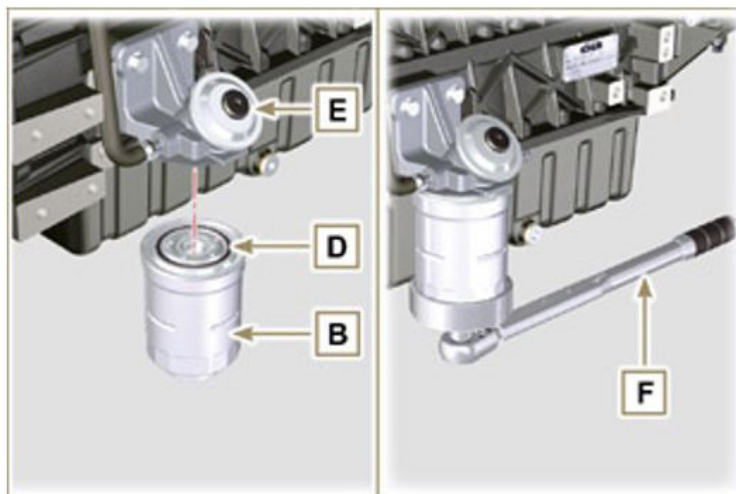

#### 6.4.18 C CHECK FILTER CARTRIDGE AND FUEL PREFILTER

Every 10 working hours carry out the above-mentioned check.



### CAUTION

#### BURN HAZARD



The operator must wear the following personal protective equipment:

- › Safety footwear
- › Gloves
- › Protective clothing
- › Protective goggle

Proceed as follows:

- › Slightly unscrew throttle screw **A** without disassembling it.
- › Drain off water if present.
- › Tighten throttle screw **A** as soon as the fuel comes out.

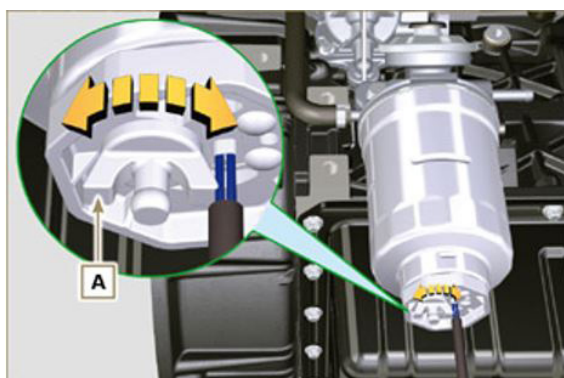



### 6.4.19 POLY-V ALTERNATOR BELT CHECK

Every 250 working hours carry out the above-mentioned check.

## WARNING

The Poly-V belt is fixed adjustment.



## CAUTION

### BURN HAZARD



The operator must wear the following personal protective equipment:

- › Safety footwear
- › Gloves
- › Protective clothing
- › Protective goggle

Proceed as follows:

- › Check the condition of the A-belt; if it is deteriorated or not intact, replace it.

## WARNING

Ensure that the ribs of belt A are inserted correctly into the grooves of pulleys B (as shown below).

- › Start the engine. After a few minutes of operation switch it off and allow it to cool down to room temperature, then check the belt tension at point **p**.
- › The vibration check has a value between 149 and 196 Hz.

## WARNING

For belt ED0024404960-S the value is between 155 and 201 Hz.

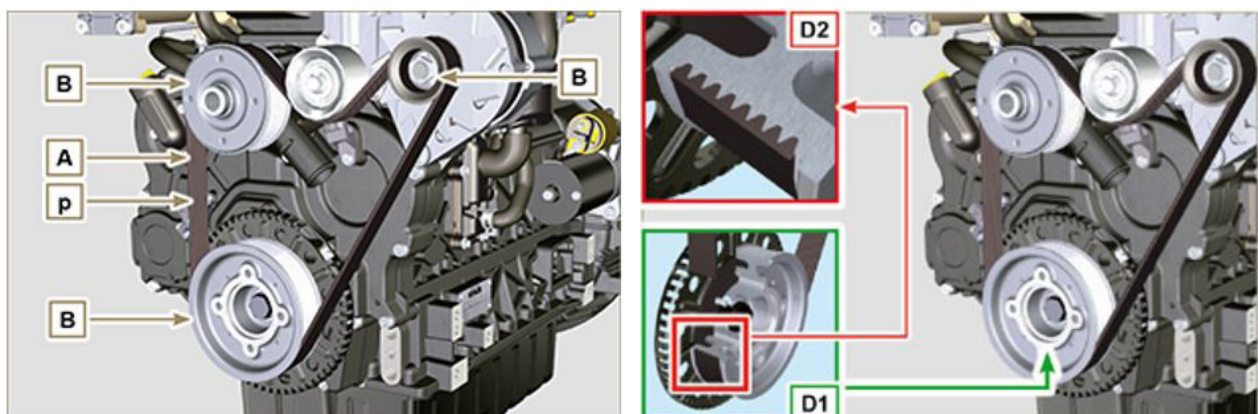



## 6.4.20 CHECK AND ADJUSTMENT OF STANDARD ALTERNATOR BELT TENSION

### CHECK

Every 250 working hours carry out the above-mentioned check.



### CAUTION

#### BURN HAZARD



The operator must wear the following personal protective equipment:

- › Safety footwear
- › Gloves
- › Protective clothing
- › Protective goggle

Proceed as follows:

- › Check the condition of the belt **A**; if it is deteriorated or not intact, replace it.
- › Check that the tension value at point **p** is between 80 and 85 Hz with an appropriate instrument.

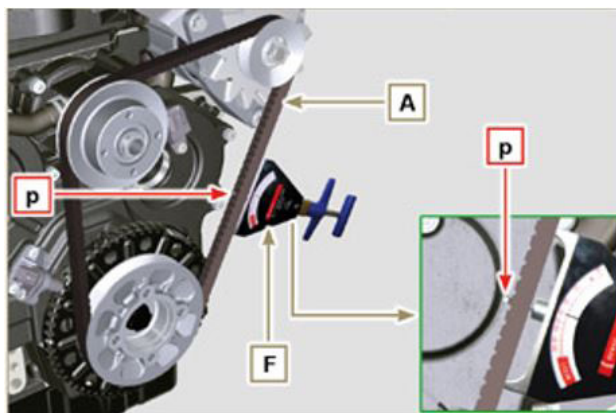

- › With the F instrument (DENSO BTG-2) shown in the figure (or similar), the corresponding value in Newtons between 350 and 450 N can be verified.
- › In the absence of instruments for correct tension verification, apply a force in the direction of the arrow **G** of approx. 10 kg at point **p**, the deflection of the belt **A** must be less than 10 mm.
- › Otherwise, carry out the adjustment

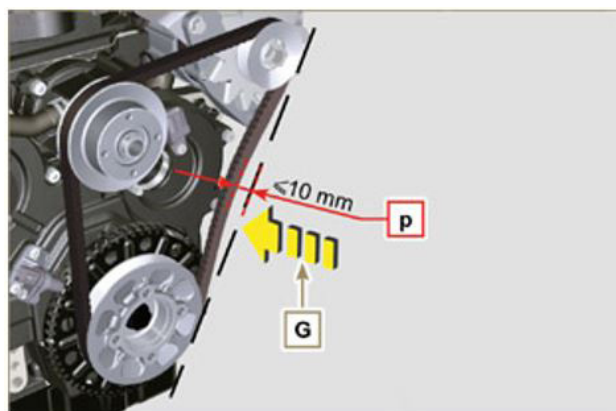



## ADJUSTMENT

Every 250 working hours proceed with the above-mentioned checko.



### CAUTION



### BURN HAZARD

The operator must wear the following personal protective equipment:

- › Safety footwear
- › Gloves
- › Protective clothing
- › Protective goggle

Proceed as follows:

- › Loosen fixing bolts **B** and **C**.
- › Pull the alternator outwards (in the direction of arrow **D**) to tension the belt.
- › While tensioning the belt, tighten bolts **B** and **C**.
- › Tighten bolts **B** (torque to 25 Nm) and **C** (torque to 69 Nm [M10 thread] - 40 Nm [M8 thread]) in sequence with torque spanner **E**.
- › Check that the tension value at point **p** is between 80 and 85 Hz with the appropriate instrument.
- › With instrument **F** (DENSO BTG-2) shown in the figure (or similar), on the other hand, it is possible to check the corresponding value in Newtons between 350 and 450 N.
- › In the absence of instruments, for a correct tension check apply a force in the direction of the arrow **G** of approximately 10 kg at point **p**; the deflection of the belt **A** must be less than 10 mm.
- › After the motor has been running for a few minutes, allow it to cool to room temperature and repeat operations 2, 3, 4 and 5 if the belt tension is outside the prescribed values.

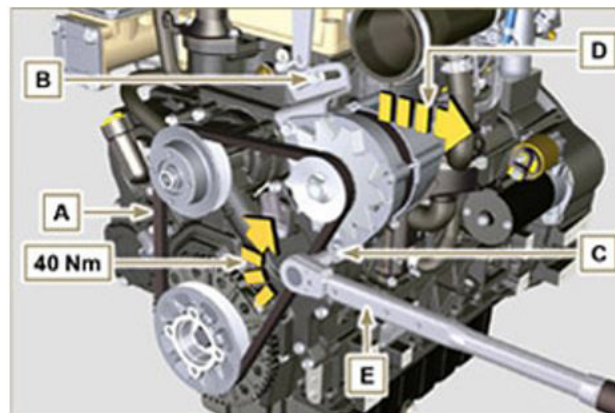



### 6.4.21 RUBBER HOSE INSPECTION

Every 500 working hours, carry out the above-mentioned check.

#### **! AVVERTENZA**

#### **BURN HAZARD**



The operator must wear the following personal protective equipment:

- › Safety footwear
- › Gloves
- › Protective clothing
- › Protective goggle

Proceed as follows:

#### **WARNING**

The inspection is carried out by lightly squeezing or bending, along the entire length of the pipe and in the vicinity of the clamps. Components must be replaced if they show cracks, cuts, leaks and do not retain some elasticity.

- › Check the integrity of the:
  - › Hoses for the fuel circuit **A**.
  - › Sleeves for the cooling circuit **B**.
  - › Hoses for the breather connection **C**.
  - › Sleeves for the air circuit **D**.
  - › Sleeves for the oil return circuit **E**.

#### **WARNING**

If the tubes are damaged, please contact the manufacturer.

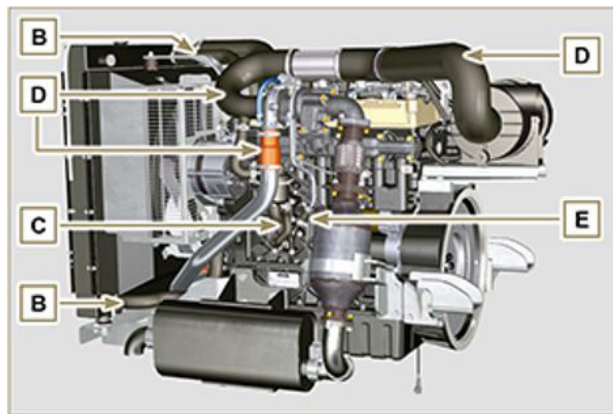
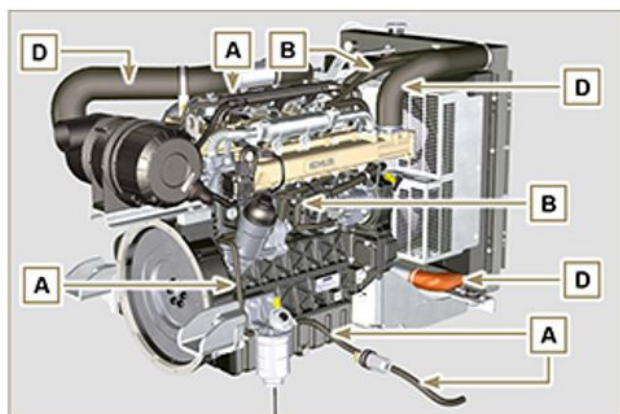

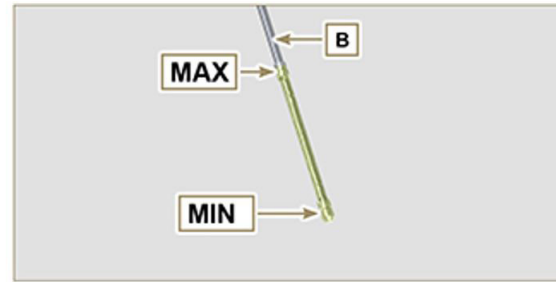
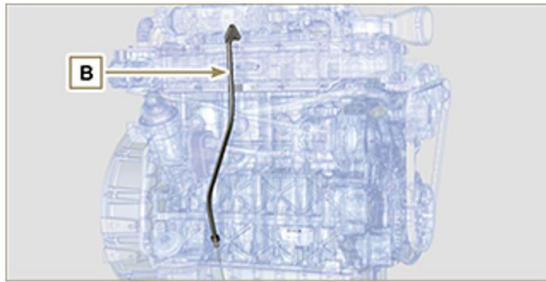
**6.4.22 OVERHEAD OIL DIPSTICK**

**6.4.23 OIL LEVEL CONTROL (STANDARD ROD)**

Every 100 working hours carry out the above-mentioned check.

**WARNING**

**Do not operate the engine with the oil level below minimum.**

**Change the oil and oil filter if the level exceeds the MAX.**

**Do not operate the engine if the oil level exceeds the MAX.**



**CAUTION**
**BURN HAZARD**

**The operator must wear the following personal protective equipment:**

- › Safety footwear
- › Gloves
- › Protective clothing
- › Protective goggle

Proceed as follows:

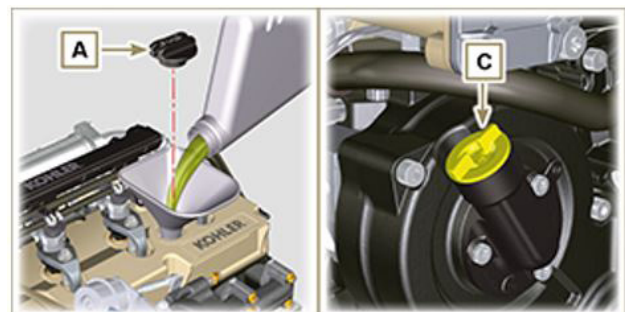
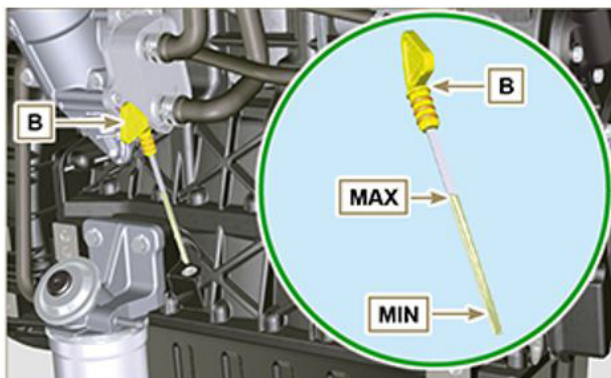
- › Unscrew oil filler cap **A**.
- › Remove oil dipstick **B** and check that the level is close to MAX.
- › Top up if the level is not close to MAX.
- › Reinsert the oil dipstick **B** correctly.
- › Re-insert cap **A** and/or **C**.





### 6.4.24 PARTICULATE FILTER CLEANING

Every 6000 working hours proceed with the above-mentioned cleaning.



## CAUTION

### BURN HAZARD

The operator must wear the following personal protective equipment:



- › Safety footwear
- › Gloves
- › Protective clothing
- › Protective goggle

Proceed as follows:

- › Open the bonnet (refer to section "6.1.1 Engine compartment bonnet").
- › Identify the particle filter **1**.
- › Clean the particle filter as indicated in Annex B.

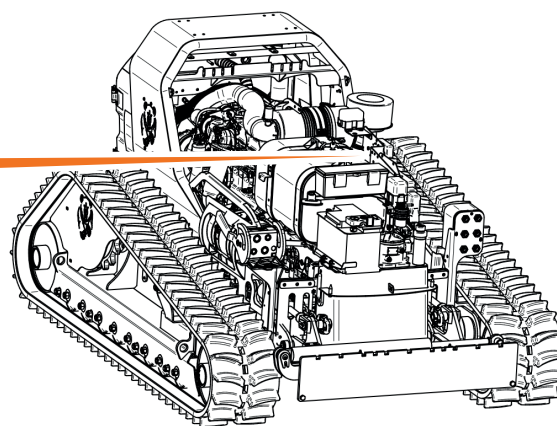
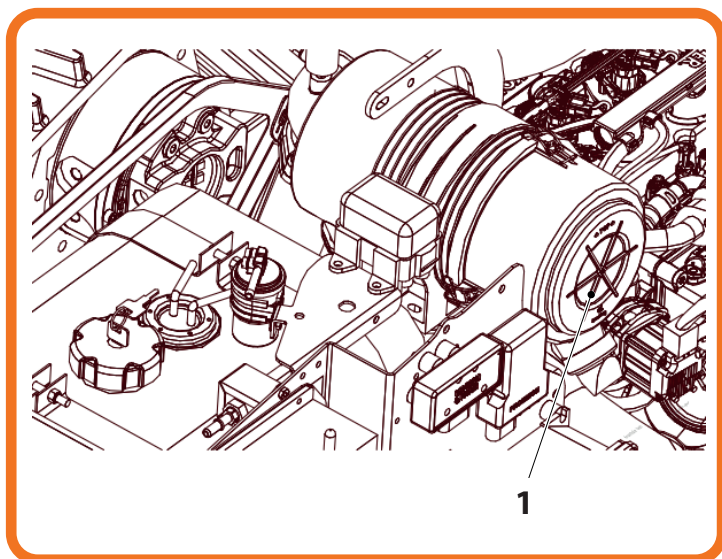



### 6.4.25 PARTICLE FILTER REPLACEMENT

Every 9000 working hours proceed with the above-mentioned replacement.

## WARNING

This operation is reserved for technicians at an MDB service centre. For this reason, please contact the MDB service centre (see chapter 2).



## CAUTION



### BURN HAZARD

The operator must wear the following personal protective equipment:

- › Safety footwear
- › Gloves
- › Protective clothing
- › Protective goggle

Proceed as follows:

- › Open the bonnet (refer to section "6.1.1 Engine compartment bonnet").
- › Identify the particle filter 1.
- › Contact the MDB service centre.

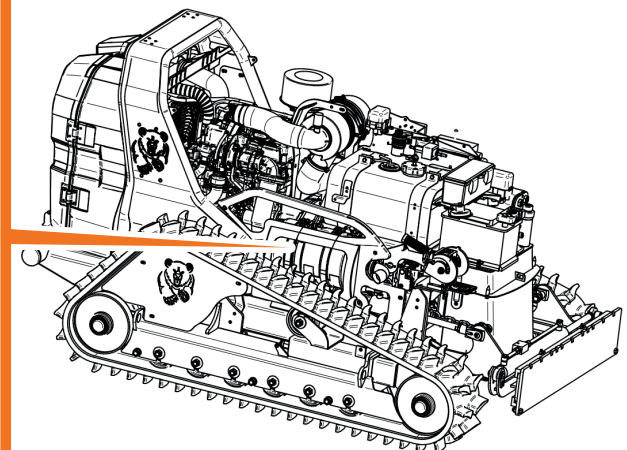
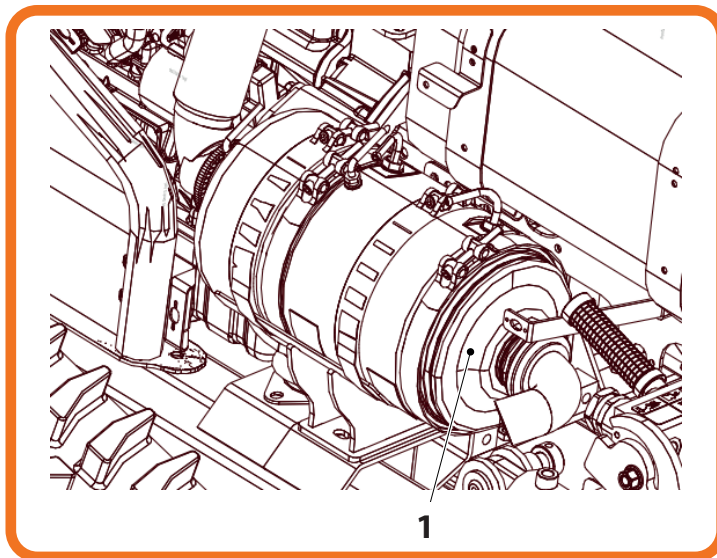



### 6.4.26 CHECKING AND TENSIONING TRACKS

Every 8 working hours carry out the above-mentioned check.



## CAUTION

The operator must wear the following personal protective equipment:



- › Safety footwear
- › Gloves
- › Protective clothing

Proceed as follows:

- › Connect hose **1** to pump **2**.
- › Connect fitting **3** to tube **1**.
- › Connect fitting **3** to the grease nipple **4**.
- › Check that the pressure gauge **5** displays a pressure of 180 bar.
- › If this condition is not met, act on lever **6** of pump 2 until the pressure of 180 bar is reached.
- › Proceed in the same way on both tracks.

## WARNING

In the event of cuts or damage to the track treads, the tracks must be replaced as described in section "6.5.1 Replacing tracks".

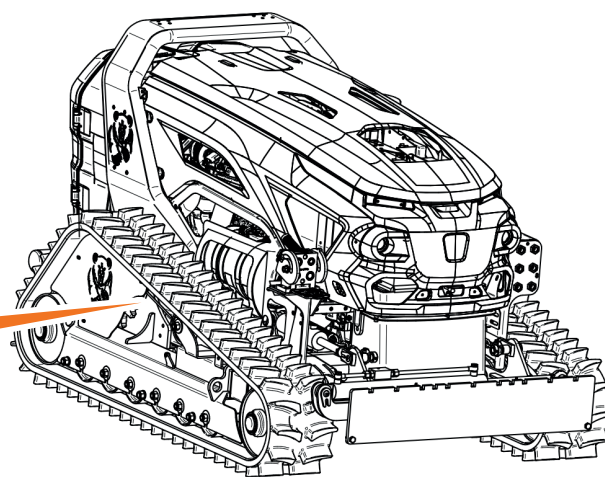
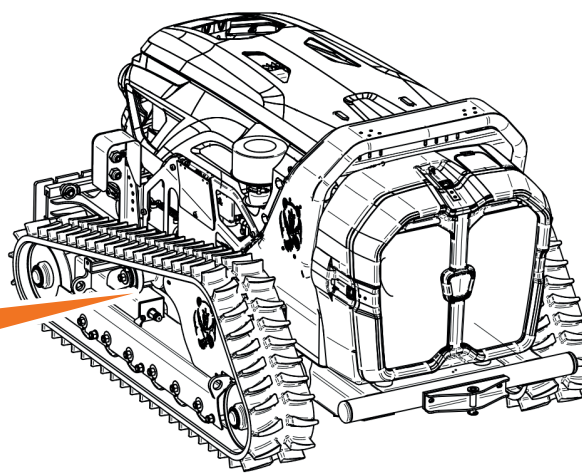
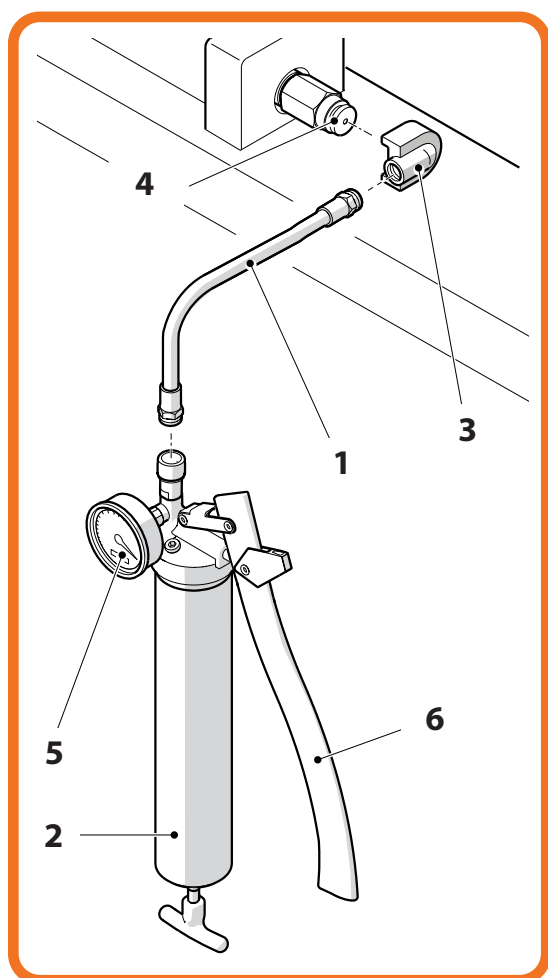



### 6.4.27 PERIODIC LUBRICATION

Every 8 working hours, lubricate the points shown in the figure.



## CAUTION

The operator must wear the following personal protective equipment:



- > Safety footwear
- > Gloves
- > Protective clothing

Proceed as follows

- > Connect hose **1** to pump **2**.
- > Connect fitting **3** to tube **1**.
- > Connect fitting **3** to the grease nipple concerned **I**.

## WARNING

Areas marked with P require manual lubrication.

For the type of product used, refer to section "3.3.4 Other technical specifications".

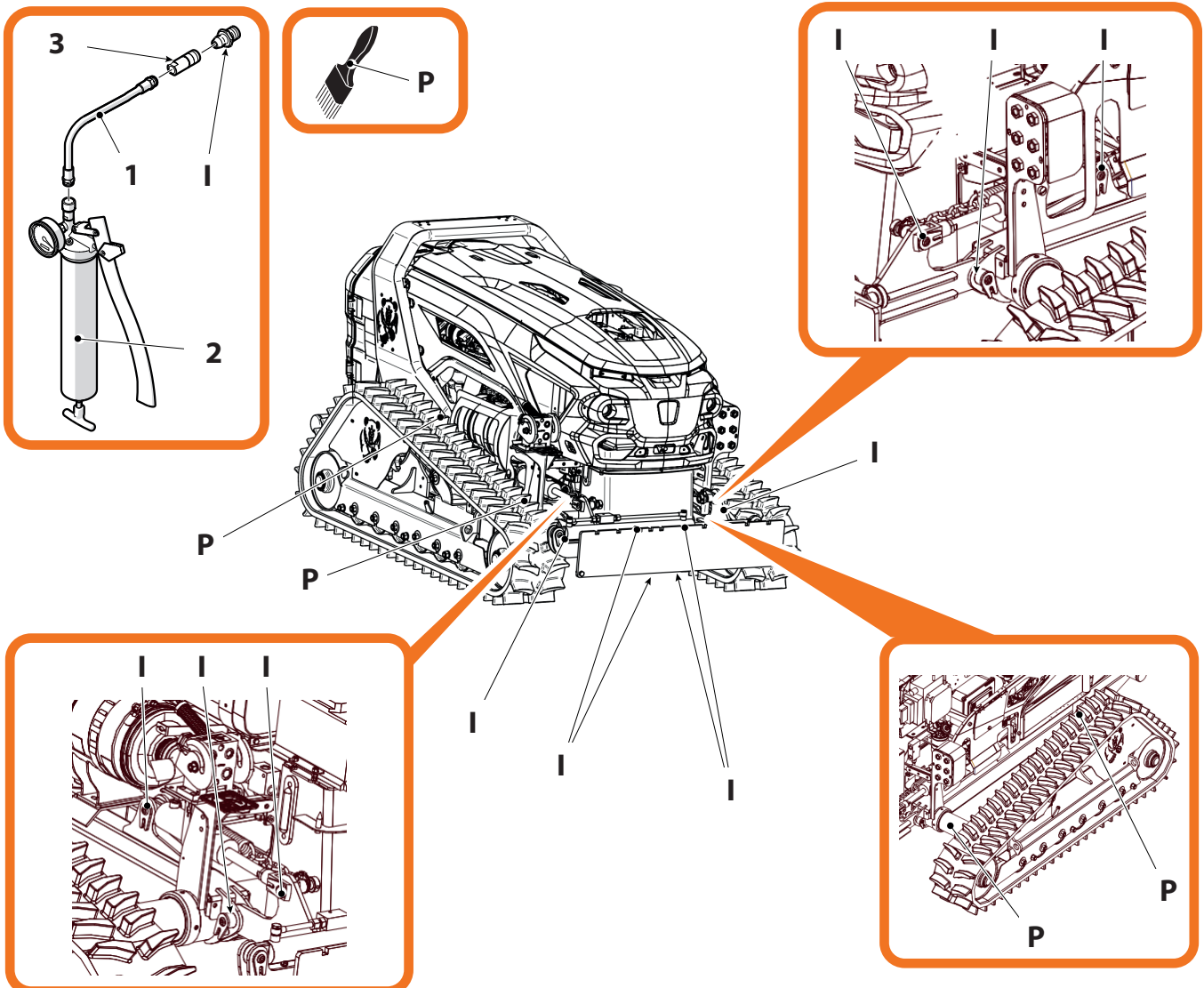



### 6.4.28 CONTROL OF CLAMPING ELEMENTS

Every 8 working hours, carry out the following checks:

- › Check the tightness of all screws.
- › Check the tightness of all nuts.
- › Check all cotter pins.
- › Check all circlips.
- › Check that all pins are locked by the cotter pin.
- › Check that all pins are locked by the appropriate snap ring.

### 6.4.29 CONTROL OF WORKING ELEMENTS

Every 500 working hours, carry out the following checks:

- › Check the wear condition and/or deformation of the tool holder plate.

**In the event of excessive wear and deformation, proceed with the relevant replacement.**

## WARNING

**The performance of these replacements is reserved for technicians from an MDB service centre. For this reason, please contact the MDB service centre (see chapter 2).**

### 6.4.30 REFRIGERATION SYSTEM CONTROL

Every 8 working hours, carry out the following checks:

- › Check that all pipes are in good condition.
- › Check that there are no leaks in the system.

### 6.4.31 HYDRAULIC SYSTEM CHECK

Every 8 working hours, carry out the following checks:

- › Check that all pipes are in good condition.
- › Check that there are no leaks in the system.

### 6.4.32 ELECTRICAL SYSTEM CHECK

Every 8 working hours carry out the above-mentioned check.



## CAUTION



**Short circuits can cause fires.**

**Do not use the machine with loose, bent and/or damaged cables or wires.**

Specifically check:

- › The integrity of electrical cables.
- › The integrity of the pipes and conduits protecting the electrical cables.
- › The functionality of the emergency buttons (refer to chapter 3).
- › The functionality of the control panel and radio control switches and buttons.
- › The functionality of the radio control unit.



## FUSE REPLACEMENT

The machine's fuses are located in two separate **A-B** zones.



### CAUTION



Short circuits can cause fires.

Do not use the machine with loose, bent and/or damaged cables or wires.

For zone **A** fuses, proceed as follows:

- › Open the bonnet (refer to section "6.1.1 Engine compartment bonnet").
- › Remove fuse 2.
- › Identify the damaged fuse and replace it, using the replacement fuse kit.

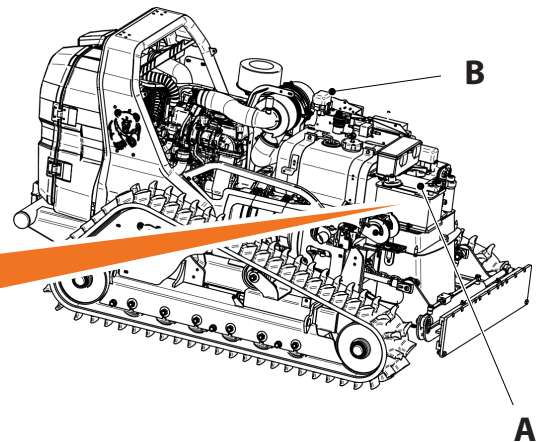
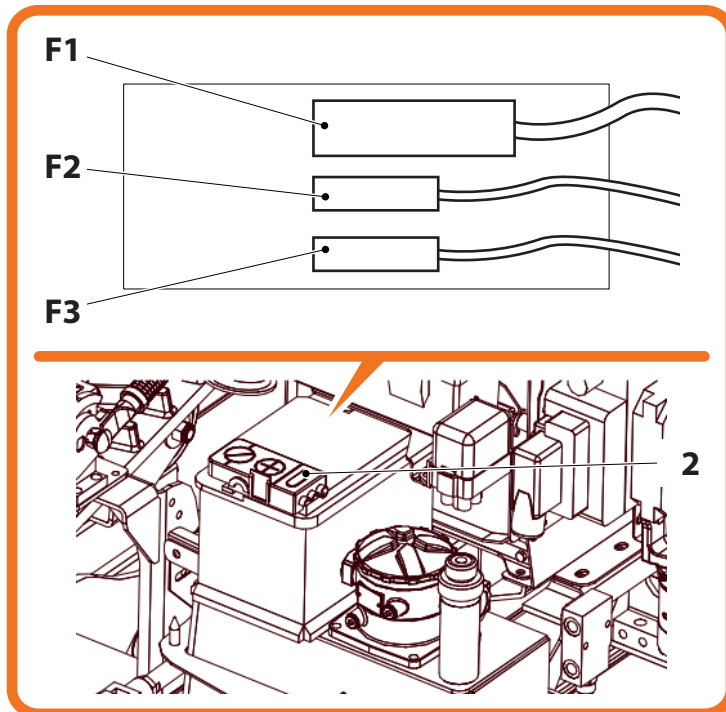

Fuse	Description	Amperage
F1	Machine and starter motor power fuse (CAL2)	50 A
F2	Starter motor relay fuse (Cable 52)	80 A
F3	Glow plug relay fuse (Cable 57)	60 A



For zone **B** fuses, proceed as follows:

- › Open the bonnet (refer to section "6.1.1 Engine compartment bonnet").
- › Remove fuse 2.
- › Identify the damaged fuse and replace it, using the replacement fuse kit.

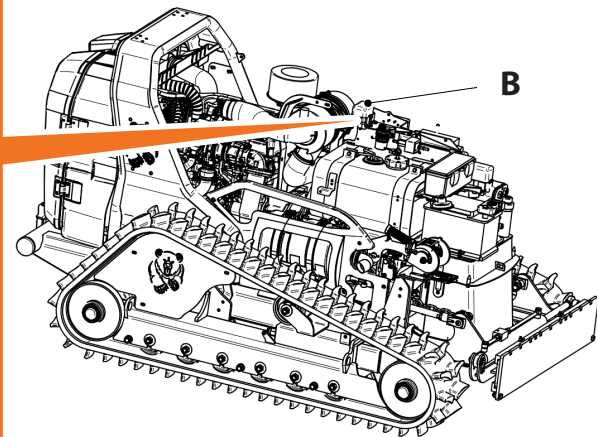
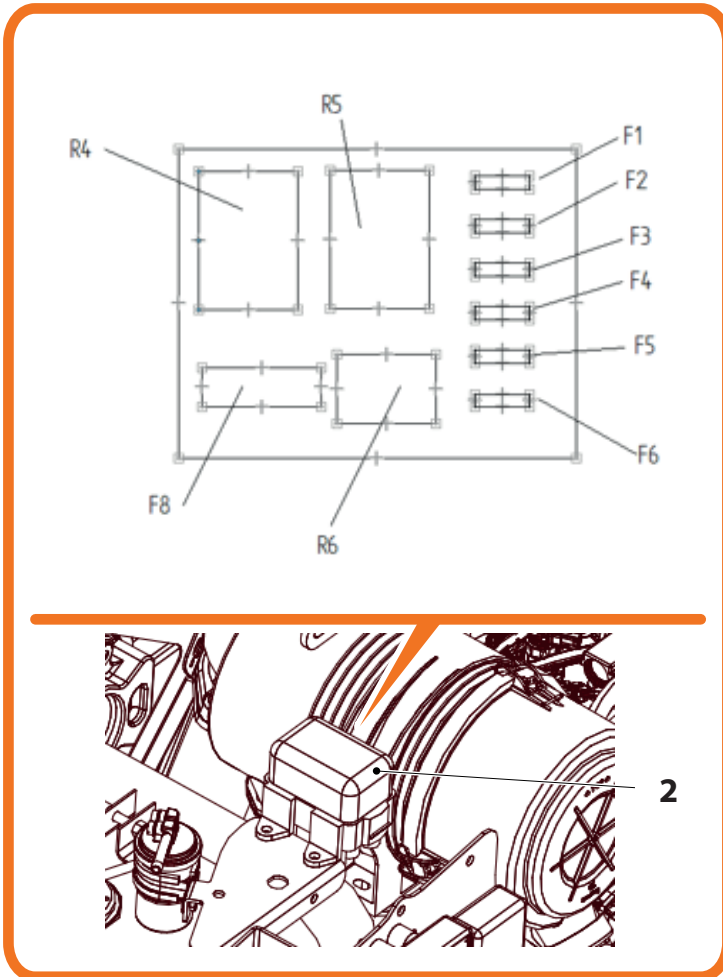

Fuse	Description	Amperage
F1	Display	20 A
F2	Claxon	5 A
F3	Obstruction lights	5 A
F4	Battery charger	5 A
F5	Cleaner	15 A
F6	Lights	3 A
R4	Main	70 A
R5	Starter delay	70 A
F8	Main	50 A
R6	A.C. pump	20 A

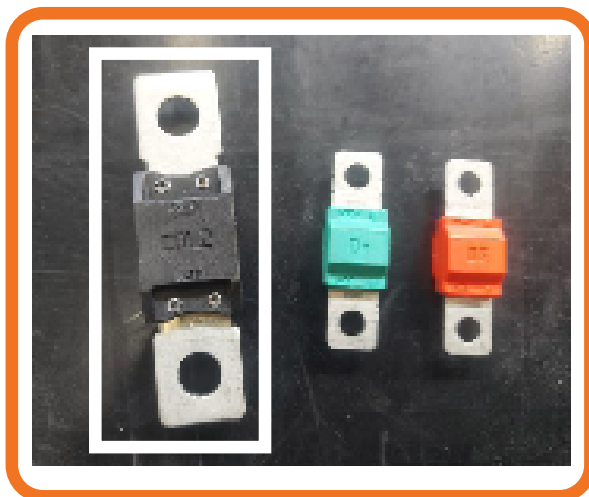
**BATTERY CABLING**

Fuse	Description	Amperage
<b>F1</b>	powerful fuse cal.2 - 32v - 400>1200°	<b>400÷1200 A</b>
<b>F2</b>	MIDIVAL 30A laminated fuse cod. 0602030	
<b>F3</b>	MIDIVAL 40A laminated fuse cod. 0602040	

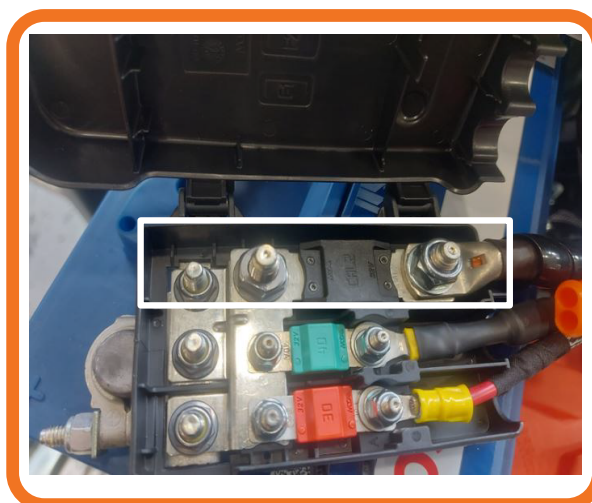

Fuse	Description	Amperage
<b>F1</b>	Starter motor positive cable	<b>400÷1200 A</b>
<b>F2</b>	KHOLER motor harness power supply positive cable	<b>30 A</b>
<b>F3</b>	Machine electrical system power supply B+	<b>40 A</b>



## MOTOR CABLING

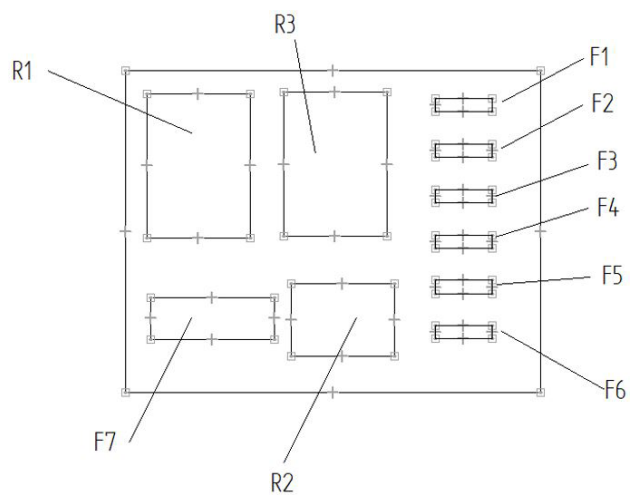
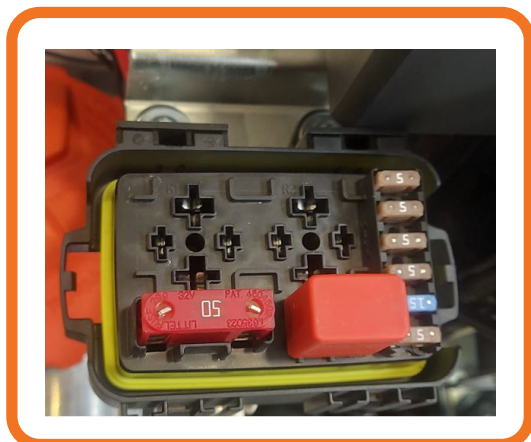

Fuse	Description	Amperage
F1	Display	5 A
F2	Claxon	5 A
F3	Obstruction lights	5 A
F4	Battery charger	5 A
F5	Cleaner	15 A
F6	Lights	5 A
R1	Lights (optional)	50 A
R2	Suction (optional)	50 A
F7	Suction	50 A
R3	Lights	30 A

## 6.5 EXTRAORDINARY MAINTENANCE

Maintenance must only be carried out by a qualified and authorised person, called the maintenance technician.

### WARNING

The maintenance person must have sufficient competence and experience to be able to assess the condition of the machine and the effectiveness of the personal protective equipment, based on technical conventions.

Extraordinary maintenance is the responsibility of MDB's technical specialists or personnel authorised by MDB.

### 6.5.1 TRACK REPLACEMENT

Replacement must be carried out when the thickness of the track tread is between 5 mm and 6 mm.

### WARNING

Replacement must, however, be carried out when cuts or damage are evident in the track tread.

Two maintenance personnel are required for this operation.



### CAUTION

#### DANGER OF SHOCK

The operator must wear the following personal protective equipment:

- > Safety footwear
- > Gloves
- > Protective clothing



Proceed as follows:

- > Position the lifting jacks under the frame in zones **1**.

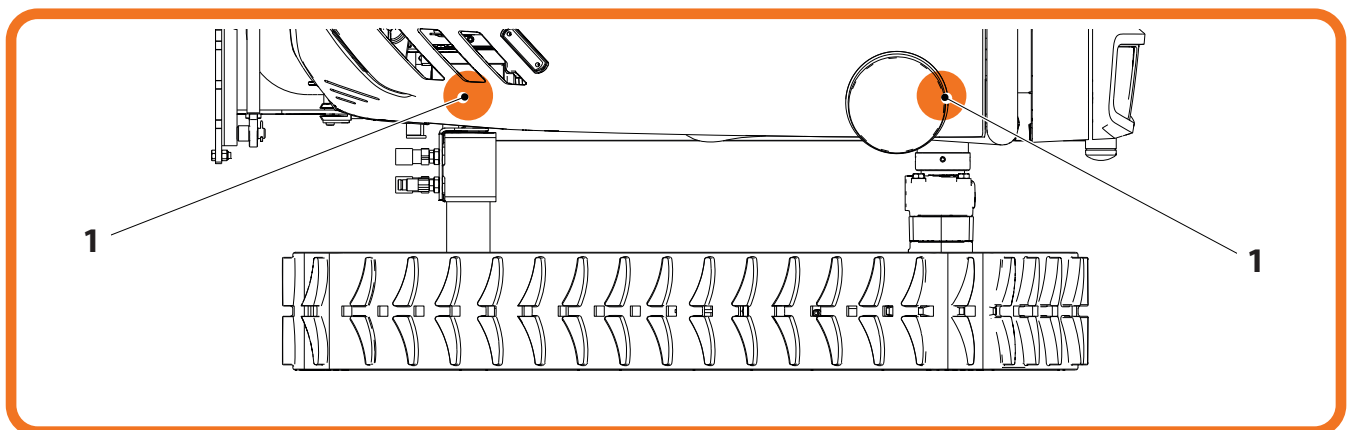



- › Raise the machine, leaving a 150 mm gap between the track and the ground.
- › Position the safety stands under the chassis in zone **2**.

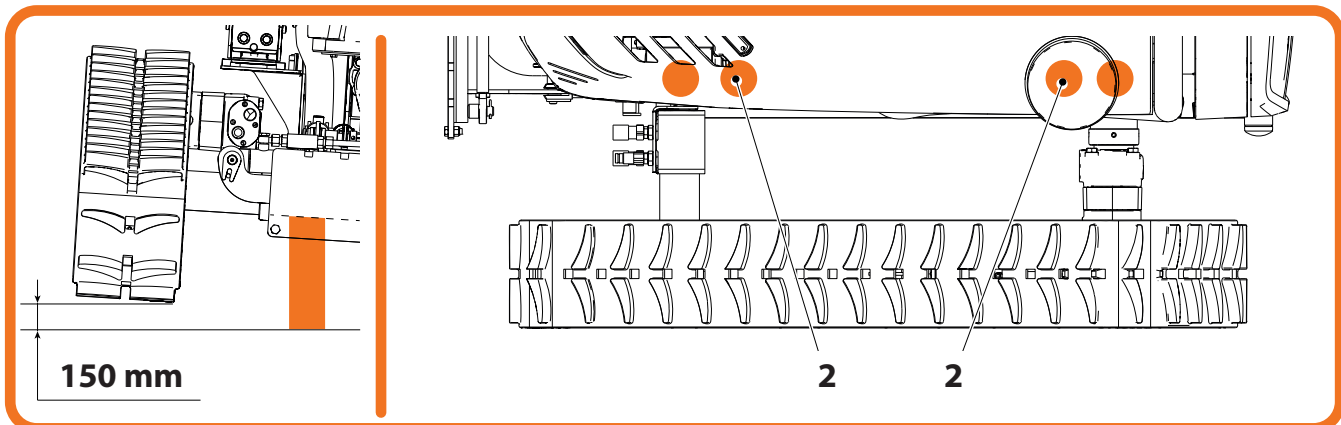

- › Unscrew screws **3** and remove casing **4**.
- › Unscrew the grease nipple **5**.
  - › Front idler wheel **6** retracts.
  - › The track loses tension.
  - › Grease escapes from area **7**. Remove leaked grease with a cloth.
- › Unscrew bolt **8** and pull out drive wheel **9**, together with the track.
- › Using a lever, pull the track out of the front idler wheel **6**, the rear idler wheel **10**, and then out of the drive wheel **9**.
- › Replace the worn track with the new one.
- › Proceed in the same way on both tracks.

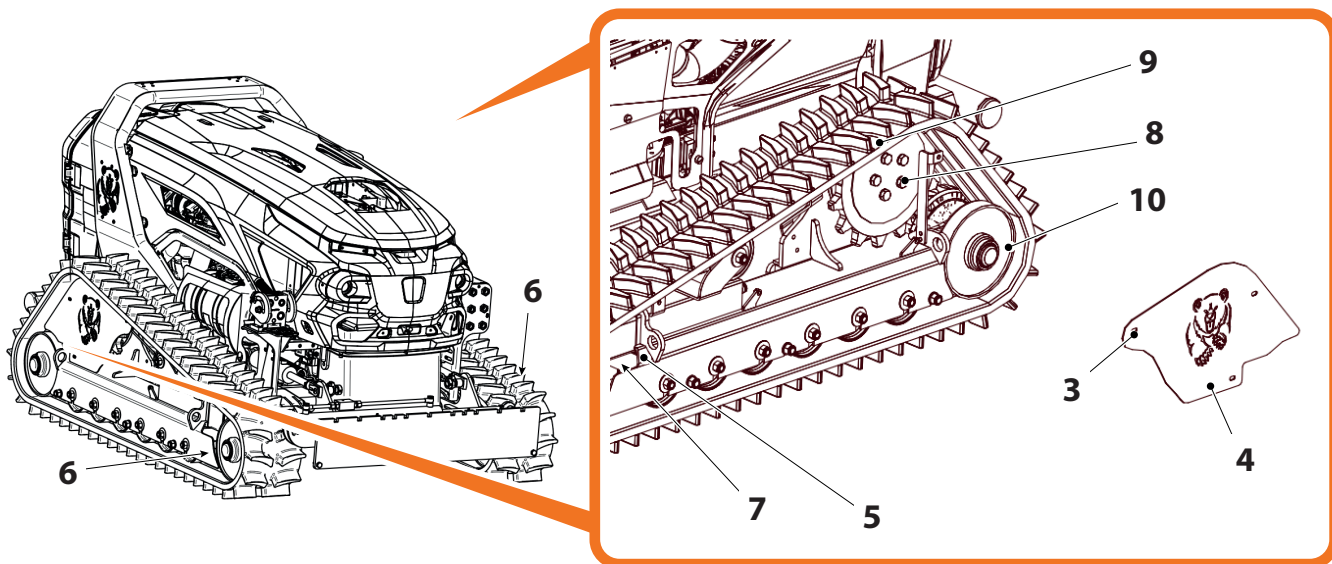
**CAUTION**

During reassembly, tighten nut **8** with a torque spanner to 500 N/m.

**WARNING**

After replacement, proceed to tensioning, as described in section '6.4.24 Checking and tensioning tracks'.







## 7 TROUBLESHOOTING

### 7.1 GUIDE TO SOLVE PROBLEMS

The following paragraphs list possible failures or faults and describe a correct method to rapidly solve the problem.

#### WARNING

**If the problem or the cause is not included in the cases indicated, contact the authorised MDB dealer.**

**For the solution of some problems, see chapter 6.**

#### 7.1.1 RADIO CONTROL

Problem	Cause	Solution
<b>The radio-control does not function</b>	The "battery isolator" key is in OFF position	Turn the "battery isolator" key to ON position
	Battery flat	Charge the battery
	The machine control panel is off	Switch on the machine control panel
	Radio-control not connected	Connect the radio-control to the control unit
	Emergency button pressed	Deactivate the emergency button
	Radio-control with serial number different to control unit	Use radio-control with the same serial number as the control unit
<b>The radio-control does not function (LED functioning, flashing or off)</b>	No radio signal	Check the radio-control connection with the control unit
	Interference with other radio signals	Use the remote control
<b>The radio-control does not function (Battery LED off)</b>	Damaged fuse	Replace the fuse
	Battery flat	Charge the battery
<b>The radio-control does not function (Battery LED flashing in a discontinuous manner)</b>	Auxiliary control activated [used for optional fixtures (if present)]	Deactivate the auxiliary control [used for optional fixtures (if present)]
<b>Radio-control battery on machine does not charge</b>	Battery charger cable disconnected	Connect the battery charger cables



## 7.1.2 MOTOR

Problem	Cause	Solution
<b>The machine does not switch on</b>	Emergency button pressed	Deactivate the emergency button
	Ignition key not inserted or disconnected	Insert and connect ignition key
	No fuel	Fill the tank
	Damaged fuse	Replace the fuse
<b>The motor switches on but the machine does not move</b>	Brakes locked/hydraulic oil cold	Repeatedly move forward and backward to release
	Pump or motor problems	Contact the authorised MDB dealer
	Speed adjustment knob on radio-control positioned on zero	Act on the speed adjustment knob until the required speed is reached
	Insufficient hydraulic oil	Top-up the hydraulic oil to the correct level
	Fuel filter and pre-filter clogged	Replace the fuel filter and pre-filter
<b>The machine switches on but does not go straight</b>	Trajectory correction knob not positioned in centre	Act on the trajectory correction knob, positioning it in the centre
	Pump solenoid valve fouled or damaged	Contact the authorised MDB dealer
	Pump or hydraulic motor damaged	Contact the authorised MDB dealer
	Damaged fuse	Contact the authorised MDB dealer
<b>The machine switches on but the machine does not move (warning light on radio-control off)</b>	No radio-control connection	Connect the radio-control to the control unit
<b>The motor switches off</b>	Electro stop failure	Contact the authorised MDB dealer
	No fuel	Fill the tank
	Emergency button pressed	Deactivate the emergency button
	Motor oil is under minimum level (indication warning light on with fixed light)	Restore the motor oil level
	Motor temperature too high (warning light on indicates the temperature of the motor is over maximum level)	Check the level of the coolant liquid and clean the radiator
	No radio signal	Connect the radio-control to the control unit



### 7.1.3 TRACKS

Problem	Cause	Solution
<b>Track slipped</b>	Too much wear of track	Replace the track
	Track mechanical structure broken	
	Track tension slack	Tension the track
<b>Track slow</b>	Track rubber worn	Tension the track
	Track tension slack	
	Track tensioning system damaged	Contact the authorised MDB dealer

### 7.1.4 BUZZER

Problem	Cause	Solution
<b>Intermittent signal when travelling</b>	Fuel almost finished	Refill the tank
	Alternator problem	Contact the authorised MDB dealer
	Scheduled maintenance due	Carry out the maintenance
<b>Intermittent signal and the machine switches off</b>	Oil level low	Do not use the machine until the cause of the problem has been solved, to avoid more serious damage Contact the authorised MDB dealer
	Motor temperature high	

### 7.1.5 INDICATION WARNING LIGHTS

Problem	Cause	Solution
<b>Battery voltage warning light on</b>	The battery voltage level is low	Recharge the battery or, if necessary, replace it
<b>Air filter warning light on</b>	The air filter is clogged	Clean the air filter or, if necessary, replace it



## 7.1.6 MOVEMENT DEVICES

Problem	Cause	Solution
<b>The machine moves but the fixture holder plate does not move</b>	Auxiliary pump and/or distributor is damaged and/or faulty	Contact the authorised MDB dealer
<b>The machine does not move but the fixture holder plate moves</b>	Adjust the speed of the radio-control set at minimum	Bring the regulator of the radio-control speed adjustment to maximum
	Radio-control fault	Contact the authorised MDB dealer
	Traction pump fault	Contact the authorised MDB dealer
	Tracks motor brakes fault	Contact the authorised MDB dealer
<b>The machine is on and in motion but the fixture holder plate does not move</b>	Hydraulic oil level low	Check for any leaks and top-up the hydraulic oil
	Machine radio-control and control unit disconnected	Check connection between radio-control and machine control unit, and connect through the relevant button



## 8 DISMANTLING



### CAUTION

The operations on the machine are to be carried out by skilled technicians who have been trained in the correct intervention and handling methods.

### 8.1 TEMPORARY PUTTING OUT OF SERVICE

In the case of a prolonged inactivity of the machine it is necessary to put it out of operation and store it in an appropriate environment, proceeding as follows:

- › Store the machine in a dry, clean environment, protected against freezing and well ventilated.
- › Thoroughly clean the machine with compressed air and soft or microfibre cloths, to completely remove dust, humidity and processing residue.
- › Check the level of the hydraulic oil: top-up the oil if necessary.
- › Apply a thin film of oil or grease on all unprotected moving parts.
- › Disable the battery turning the "battery isolator" key to OFF position.
- › Deactivate the battery disconnecting the cables.
- › Apply a suitable protective spray on all exposed electrical contacts.
- › Cover the machine to protect it against dust; do not use plastic film since this could cause formation of condensation, use vapour -proof sheets.

### 8.2 PERMANENT PUTTING OUT OF SERVICE- DISMANTLING

At the end of the machine production-cycle life, dismantle, proceeding as follows.

### WARNING



Dispose of any chemical substances, lubricants and waste hydraulic oils in compliance with the standards in force in the country where the machine is used.

Dispose of the machine in a manner to be able to recycle the different materials, in compliance with the standards in force in the country where the machine is used.



### CAUTION

The machine contains liquids that are potentially inflammable, such as fuel, hydraulic oil, battery acid.

- › Empty the fuel tank completely.
- › Empty the tank and plant hydraulic oil circuit completely.
- › Empty the coolant from the radiator completely.
- › Proceed to disassemble all the components, taking care to separate the different materials: steel, non-ferrous metals fibreglass, plastic, rubber, etc.
- › Dispose of fluids and solid materials safeguarding the environment, and handing over all the materials to specialised companies.

### WARNING

If the disposal is carried out by a specific specialised company, this manual is to accompany the machine.



***MDB***

