



OPERATION AND MAINTENANCE MANUAL

HYDRAULIC FORKLIFT



📖 Read this manual in its entirety prior to operating the machine 📖

English translation of original instructions

Edition July 2010

DECLARATION OF CONFORMITY

DICHIARAZIONE DI CONFORMITÀ

Declaration of Conformity · Konformitätserklärung

Déclaration de Conformité · Declaración de Conformidad



La ditta sottoscritta: *The undersigned Company: Die unterzeichnete Firma: La société soussignée: La Empresa abajo firmante*

C.M. srl
Via Bedazzo, 39 – 48022 – LUGO (RA) – ITALY

Dichiara sotto la propria responsabilità che la macchina: *Declares under its sole responsibility that the machine: Declares sous son entière responsabilité que la machine: erklärt unter eigener Verantwortung, dass die Maschine: Declara bajo su responsabilidad que la máquina:*

ELEVATORE IDRAULICO HYDRAULIC FORKLIFT ELEVATEUR HYDRAULIQUE
HYDRAULISCHER STAPLER ELEVADOR HIDRÁULICO

Modello / *Type / Modèle / Modell / Modelo*

N°matricola / *Serial N° / N°matricule / Seriennummer / N°de matricula*

Anno di costruzione / *Year of manufacture / Année de construction / Baujahr / Año de fabricación*

Avente funzione di movimentazione e trasporto di pallets, bancali, bins. *For handling pallets and bins. zum Bewegen und Transportieren von Paletten und Behältern. Pour la manutention et le transport de palettes et bins. Para el desplazamiento de pallets y bins.*

E' conforme alla Direttiva 2006/42/CE. Per l'adeguamento della macchina sono state consultate le seguenti Norme Armonizzate: UNI EN ISO 4254-1 2010
complies with the provisions of the Directive 2006/42/EC. The machine is constructed in accordance with harmonized standards UNI EN ISO 4254-1 2010.

der Richtlinie 2006/42/EG entspricht. Zur Anpassung der Maschine wurden die folgenden harmonisierten Normen herangezogen: UNI EN ISO 4254-1 2010

Est Conforme à la Directive 2006/42/CE. Les normes harmonisées suivantes ont été consultées pour la mise au point de la machine : UNI EN ISO 4254-1 2010

Está Conforme a la Disposición 2006/42/CE. Para el ajuste de la máquina han sido consultadas las normas armonizadas siguientes: UNI EN ISO 4254-1 2010

Detentore del Fascicolo Tecnico, presso la sede aziendale / *The technical construction file is maintained at the company headquarters / Titulaire du dossier technique, au siège de la société / Gewahrsamsinhaber der technischen Unterlagen in der Hauptniederlassung / Titular de la documentación técnica, en la sede de la empresa: Calonaci Domenico – Legale Rappresentante / Legal Representative / Représentant légal/ Gesetzlicher Vertreter / Representante legal*

Lugo,

CALONACI DOMENICO

The information in this publication describes the safety requirements, operation, maintenance and servicing of the machine.

This manual is divided into chapter for easy consultation.

The information given in this manual is intended for authorized professional users. The operators must be well instructed, properly trained and fully understand the environment in which the machine is used.

Customers are strongly advised to use only genuine replacement parts and accessories. The use of non-genuine parts will not only void the warranty but may create safety hazards hampering machine performance and its service life.

COPYRIGHT BY C.M. srl

The technical information given in this manual is the property of **C.M. srl**.
This publication or parts of it are valuable trade secrets.

Reproduction of the text and illustrations in whole or in part is prohibited.

TABLE OF CONTENTS

DECLARATION OF CONFORMITY 2

1 INTRODUCTION..... 6

1.1 GLOSSARY 7

1.2 MANUFACTURER'S INFORMATION..... 8

1.3 NAMEPLATE 8

1.4 USI PREVISTI INTENDED USE OF THE MACHINE..... 9

 1.4.1 Intended use 9

 1.4.2 Unintended use..... 10

1.5 TECHNICAL SPECIFICATIONS 12

1.6 IDENTIFICATION OF THE COMPONENTS 15

1.7 DESCRIPTION OF THE MAIN COMPONENTS 16

1.8 AIRBORNE NOISE LEVEL 16

1.9 STORING – GARAGING..... 17

1.10 PUTTING THE FORKLIFT BACK INTO OPERATION 17

1.11 DISPOSAL 18

2 SAFETY GUIDELINES 19

2.1 OPERATOR REQUIREMENTS 20

2.2 ACCIDENTAL PREVENTION AND SAFETY STANDARDS..... 21

2.3 SAFETY SYMBOLS 26

 2.3.1 Description of the pictograms..... 26

 2.3.2 Location of the pictograms on the machine..... 27

3 SHIPMENT 27

4 MOUNTING THE HYDRAULIC FORKLIFT ON THE TRACTOR..... 28

4.1 TRACTOR FEATURES..... 28

4.2 MOUNTING 29

4.3 HYDRAULIC CONNECTIONS..... 32

 4.3.1 Connection to the tractor's quick connect couplers 33

 4.3.2 Connecting the pump-booster assembly to the tractor 34

 4.3.3 Hydraulic connection to tractor with cab 35

4.4 MOUNTING THE FORKLIFT WITHOUT ITS OWN DISTRIBUTOR..... 37

4.5 INSTALLING THE DOUBLE TIPPER KIT 37

5 STABILITY 38

5.1 HYDRAULIC FORKLIFT STABILITY 38

5.2 UNIT STABILITY AND BALLASTING..... 38

6 CONTROLS 40

6.1 HYDRAULIC DISTRIBUTORS 40

 6.1.1 Standard hydraulic distributor 40

 6.1.2 Remote hydraulic distributor 42

 6.1.3 Tractor auxiliary distributor 42

6.2 ELECTROHYDRAULIC DISTRIBUTORS..... 43

 6.2.1 Selector with electro-hydraulic control monolever..... 43

6.2.2	Distributor with electric control panel.....	45
7	CHECKS AND ADJUSTMENTS.....	47
7.1	CHECKS.....	47
7.2	ADJUSTING THE FORKS.....	49
7.2.1	Adjusting folding forks.....	49
7.2.2	Adjusting the FEM forks.....	50
7.3	ADJUSTING THE LOAD CLAMP.....	50
8	OPERATION OF THE HYDRAULIC FORKLIFT.....	51
8.1	LOADING STAGE.....	52
8.2	HANDLING STAGE.....	53
8.3	UNLOADING STAGE.....	53
9	ROAD TRAVEL.....	54
10	DISMOUNTING THE HYDRAULIC FORKLIFT.....	54
11	MAINTENANCE.....	55
11.1	OVERVIEW.....	55
11.1.1	Maintenance chart.....	57
11.2	HYDRAULIC SYSTEM MAINTENANCE.....	58
11.2.1	Checking and replacing the hydraulic oil.....	60
11.3	TROUBLESHOOTING CHART.....	61
12	ACCESSORIES.....	62
13	INTERCHANGEABLE EQUIPMENT.....	63
14	REPLACEMENT PARTS.....	64
15	WARRANTY.....	65

1 INTRODUCTION

Studying and adhering to the procedures and instructions given in this manual will assure optimum machine performance, longevity of the components and prevent workplace accidents, injuries and machine damage.

This manual should be thoroughly read and understood to become familiar with the hydraulic forklift prior to operation.

This manual should be considered a fundamental part of the machine and accompany it if the machine is sold and until it is decommissioned.

Some illustrations provided in the manual show the parts or accessories that may be different from those installed in your machine and some components may be removed for purposes of clarity.

C.M. srl reserves the right to make any modifications at any time without prior notice in its ongoing commitment to improve quality and overall safety without updating the manual.

The subjects dealt with in this manual are those expressly set forth by "Directive 2006/42/EC and applicable technical standards.

The machine comes with safety decals. The operator must assure they are always clearly visible and replace them when they are no longer readable.

The following signals words are used with the safety alert symbol:

DANGER!

WARNING!

CAUTION!



throughout the manual to call your attention to safety and correct machine operation. Learn to recognize these safety alerts and follow the recommended precautions and safe practices.

The manual has been compiled in accordance with regulations in force at the time of print.

It is an essential part of the machine and must accompany it, together with the CE declaration of conformity, even if the machine is re-sold.



CAUTION!

Thoroughly read and understand the Operation and Maintenance manual in its entirety before attempting to use the forklift and perform any type of work.

Special care must be taken to keep this manual safe from the weather and in readable conditions. The manual must be readily accessible for future reference if questions or concerns arise.

The Customer Service Department at **C.M. srl** can assist if the manual or parts of it are not understood.

1.1 GLOSSARY

In order to clearly understand the terminology used throughout this manual, some of the technical terms commonly encountered when operating an hydraulic forklift are explained below:

LIFT: load movement in vertical direction

TRAVEL: load movement in transverse direction in relation to tractor forward travel

TIP: tip in relation to vertical position of load's lift axis (forklift forward or back)

SAFETY DECAL: graphic alert symbol attached to the machine to point out areas where residual risks are posed and call the operators attention to take recommended precautions and safe practices.

CLAMP: mechanical device used to firmly secure the load through the pressure exerted from above by an hydraulically-actuated movable support.

FEM FORKS: adjustable width forks.

1.2 MANUFACTURER'S INFORMATION

C.M. srl

Via Bedazzo, 39

48022 - LUGO (RA) - ITALY

C.F. / VAT NO. / Reg. Imprese RA: 00269380390

R.E.A. n° 80762 CCIAA Ravenna

Authorized capital: 51,645,68 i.v.

tel. +39 0545 34134

e-mail cm@cm-elevatori.it

fax +39 0545 32117

web www.cm-elevatori.it

1.3 NAMEPLATE

A nameplate containing the CE mark, information about the manufacturer, the machine model and serial number, year of manufacture, weight, maximum capacity, operating pressure of the hydraulic circuit, maximum lift height and center of gravity of the load is attached on the back of each forklift.



Nameplate

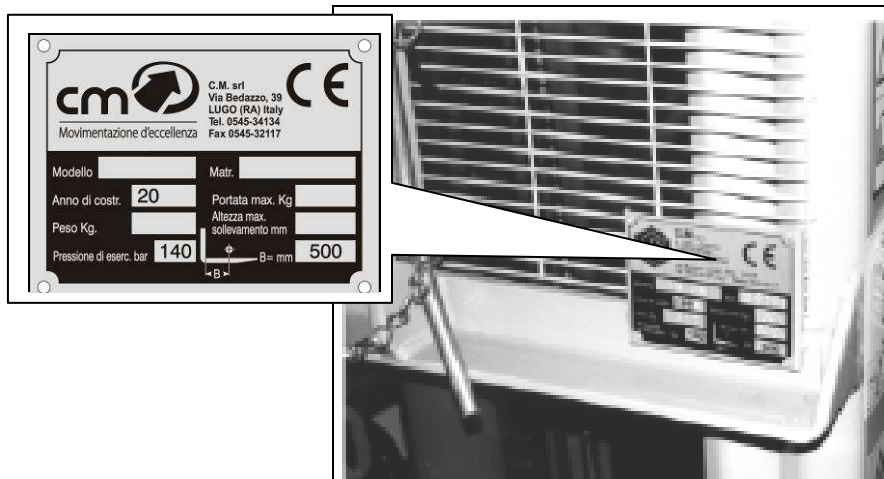

Location of nameplate

Location of **nameplate** on the machine



CAUTION!

Whenever ordering replacement parts, always supply the information given on the nameplate.

Before leaving the production facility, this specific model underwent stringent inspection and testing to assure unsurpassed reliability.

1.4 USI PREVISTI INTENDED USE OF THE MACHINE

1.4.1 Intended use

The C.M. hydraulic forklifts are designed and constructed to lift, handle and store crates, pallets and bins containing agricultural products. C.M. hydraulic elevators are designed and manufactured to be used attached to the back of a tractor in most cases or, less frequently, at the front. They are operated by just one operator sitting in the driver's seat of the tractor.

The machine is designed or intended for use only in the agricultural industry.

In particular, no passengers are allowed. Do not carry passengers anywhere on the C.M. hydraulic forklift.

The manufacturer may install specific accessories on the C.M. forklifts, as illustrated in par. **12 Accessories** in this publication.

As far as use of the **clamp** is concerned, it is strongly recommended to observe the following size limits for the load to be handled when the forklift is attached at the front of the tractor: **1200 xx x 1200 mm base x 1500 mm height**. In exceptional cases when the forklift needs to be used to handle bulky loads or in any case, a single item that is close to the recommended size limits, the clamp can be used. When working under poor visibility conditions a ground signalman using the hand signals set forth in Directive 92/58/EC must be present to give manoeuvring instructions to the operator.

The hydraulic forklift is designed and engineered for operation under environmental conditions present in central Europe at a temperature ranging from -10°C to $+40^{\circ}\text{C}$. Use under extreme environmental conditions (for example very dusty environments) may require more maintenance.

It is very important that all the workplace health and safety regulations and accident prevention norms currently in force are followed when operating the machine.

As far as driving the tractor with the hydraulic forklift attached on public roads is concerned, always follow the highway code.



WARNING!

**This machine must be used by just one well-instructed and properly trained operator.
Use different from that specified is to be considered unintended, inappropriate and erroneous.**

Using the machine correctly, carefully following the safety guidelines given herein and taking all the precautions to ward off hazards will prevent accidents or injuries from occurring while assuring top machine performance over time and cutting down faults to minimum.

C.M. srl shall not be held responsible for any consequences deriving from failure to heed the safety rules, procedures and precautions given in this manual.

1.4.2 Unintended use

Any use of the C.M. hydraulic forklift in manners different from those stated in paragraph **1.4.1 Intended use** is to be considered unintended, inappropriate and erroneous.

Unintended use of the hydraulic forklift may cause serious hazards for the operator and any bystanders who, for any reason, are within the range of action of the machine.

The machine may be used only where good lighting is assured. The machine must not be used under poor lighting conditions.

**WARNING!**

**The machine is designed to carry only agricultural products.
No passengers are allowed. Do not use the hydraulic forklift to
carry passengers.**

Any random modifications made to this machine will void the warranty and **C.M. srl** shall not be held liable for any property damage or injury, even serious, to the operators and third parties. The manufacturer cannot foresee all possible situations of unintended and inappropriate machine use. The most frequently encountered and reasonably foreseeable cases of misuse are given below:

- Attaching the hydraulic forklift to tractors whose weight or capacity is inadequate for the forklift model being used.
- Mounting ballast that are inadequate, incorrect size, makeshift or not well-secured.
- Working without first securing the anti-shaking rods of the tractor's three-point hitch system.
- Working without first securing the control lever for the arms of the tractor's hydraulic lift.
- Using the hydraulic forklift without accurately securing the dowels, cotter pins and safety pins present in the machine.
- Using the hydraulic lift's cylinder to aid in lifting.
- Removing, locking out, disabling or not re-arming the safety devices when necessary (valves, grids, etc...).
- Tipping the forklift forward with the load raised on the forks while the load is being transported.
- Using the forklift on steep grounds and surfaces.
- Installing the hydraulic forklift on tractors that do not meet the minimum safety requirements (in particular, not provided with tip-over protective measures such as seat belts and rollover protective structures (ROPS) and falling object protective structures (FOPS)).

- Lifting and/or carrying passengers on the forks.
- Failure to heed the size limits for the load handled.
- Using the **clamp** installed at the front of the tractor with loads whose dimensions are different from those given on page 10, if a "reversible drive tractor" is not used.
- Using a fully loaded hydraulic forklift under poor visibility conditions without the aid of a ground signalman.
- Installing the hydraulic forklift on articulated tractors.

1.5 TECHNICAL SPECIFICATIONS

The charts below show the models of hydraulic forklifts manufactured by C.M. srl which the information and instructions given herein refer to. It is strongly recommended to highlight your forklift model to quickly and easily identify the relevant specifications and performance values.

Machine technical specifications

Duplex

MODELS			5 DLS			9 DCL			
C	Lift height	mm	1600	2000	2500	2000	2200	2500	3000
H	Max. overall dimensions	mm	1400	1600	1850	1600	1700	1850	2100
-	Weight	kg	124	140	162	240	250	270	300
B	Min. spread	mm	-			950			
A	Max. spread	mm	-			1800			
L	Forklift width	mm	600			650			
T	Ground clearance	mm	200			200			
E	Fork spread	mm	620			500÷620			
D	Load center of gravity	mm	400			400			
Q	Max. capacity	kg	500			900			
	Power requirements	CV	30÷40			40÷50			

MODELS			16 DC						
C	Lift height	mm	1600	2000	2500	3000	3200	3600	4000
H	Max. overall dimensions	mm	1580	1780	2050	2300	2400	2600	2800
-	Weight	kg	328	344	370	384	392	410	430
B	Min. spread	mm	1100	1350					
A	Max. spread	mm	1950	2450					
L	Forklift width	mm	700						
T	Ground clearance	mm	300						
E	Fork spread	mm	490÷720						
D	Load center of gravity	mm	500						
Q	Max. capacity	kg	1600						
	Power requirements	CV	60÷70						

16 DH				
2500	3200	3600	4000	4500
1950	2300	2500	2700	2950
380	440	470	500	540
1350				
2450				
700				
300				
490÷720				
500				
1600				
60÷70				

MODELS		16 DBCH						20 DBCH				
C	Lift height	mm	2200	2800	3200	3600	4000	4500	3200	3600	4000	4500
H	Max. overall dimensions	mm	1800	2100	2300	2500	2700	2950	2400	2600	2800	3050
-	Weight	kg	400	440	470	500	530	570	690	730	770	820
B	Min. spread	mm	1350						1350			
A	Max. spread	mm	2450						2450			
L	Forklift width	mm	700						800			
T	Ground clearance	mm	300						300			
E	Fork spread	mm	490+720						240+1200			
D	Load center of gravity	mm	500						500			
Q	Max. capacity	kg	1600						2000			
	Power requirements	CV	60+70						80+90			

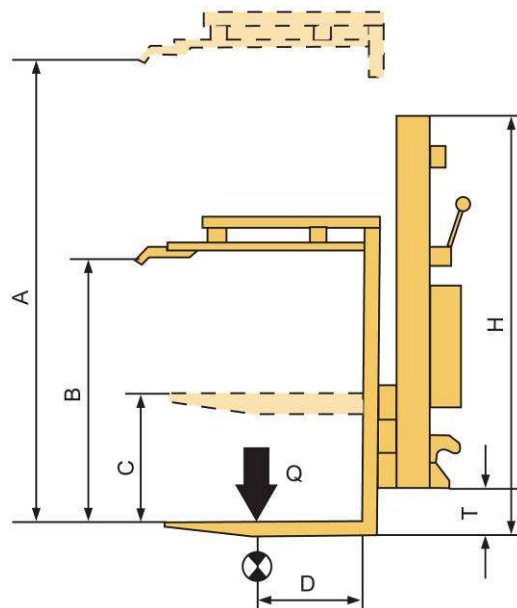
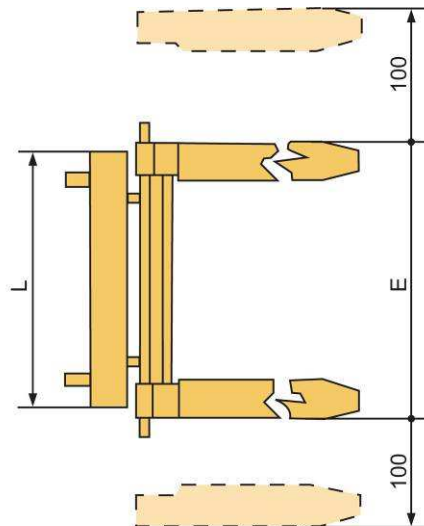

Triplex

MODELS		9 TCL		16 TC				16 THAL				
C	Lift height	mm	2500	3000	2500	3000	3200	3600	2500	3000	3200	3600
H	Max. overall dimensions	mm	1430	1600	1480	1730	1790	1930	1480	1650	1730	1850
-	Weight	kg	280	310	350	395	410	450	390	445	465	510
B	Min. spread	mm	950		1100	1350			1100	1350		
A	Max. spread	mm	1800		1950	2450			1950	2450		
L	Forklift width	mm	650		700				700			
T	Ground clearance	mm	200		250				250			
E	Fork spread	mm	500÷620		490÷720				490÷720			
D	Load center of gravity	mm	400		500				500			
Q	Max. capacity	kg	900		1600				1600			
	Power requirements	CV	40÷50		60÷70				60÷70			

MODELS		16 TBCH							20 TBCH						
C	Lift height	mm	2500	3000	3200	3600	4000	4500	5200	3200	3600	4000	4500	5200	6000
H	Max. overall dimensions	mm	1560	1730	1790	1930	2130	2300	2530	1850	2000	2150	2300	2550	2800
-	Weight	kg	438	470	480	520	555	600	680	715	750	790	840	930	1130
B	Min. spread	mm	1100	1350						1350					
A	Max. spread	mm	1950	2450						2450					
L	Forklift width	mm	700							800					
T	Ground clearance	mm	250			300				300					
E	Fork spread	mm	490÷720							240÷1200					
D	Load center of gravity	mm	500							500					
Q	Max. capacity	kg	1600							2000					
	Power requirements	CV	60÷70							80÷90					

Quadruplex

MODELS		16 QHAL			
C	Lift height	mm	2500	3300	4000
H	Max. overall dimensions	mm	1280	1480	1650
-	Weight	kg	470	520	580
B	Min. spread	mm	1100	1350	
A	Max. spread	mm	1950	2450	
L	Forklift width	mm	700		
T	Ground clearance	mm	250		
E	Fork spread	mm	490÷720		
D	Load center of gravity	mm	500		
Q	Max. capacity	kg	1600		
	Power requirements	CV	60÷70		

Hydraulic system specifications

Tank capacity	lt	7 – 10 - 15
Required delivery rate for hydraulic system	lt/min	40

C.M. srl strongly recommends contacting the manufacturer to obtain information or instructions regarding chain maintenance when using the hydraulic forklift.

1.6 IDENTIFICATION OF THE COMPONENTS

Duplex / triplex/quadruplex forklifts

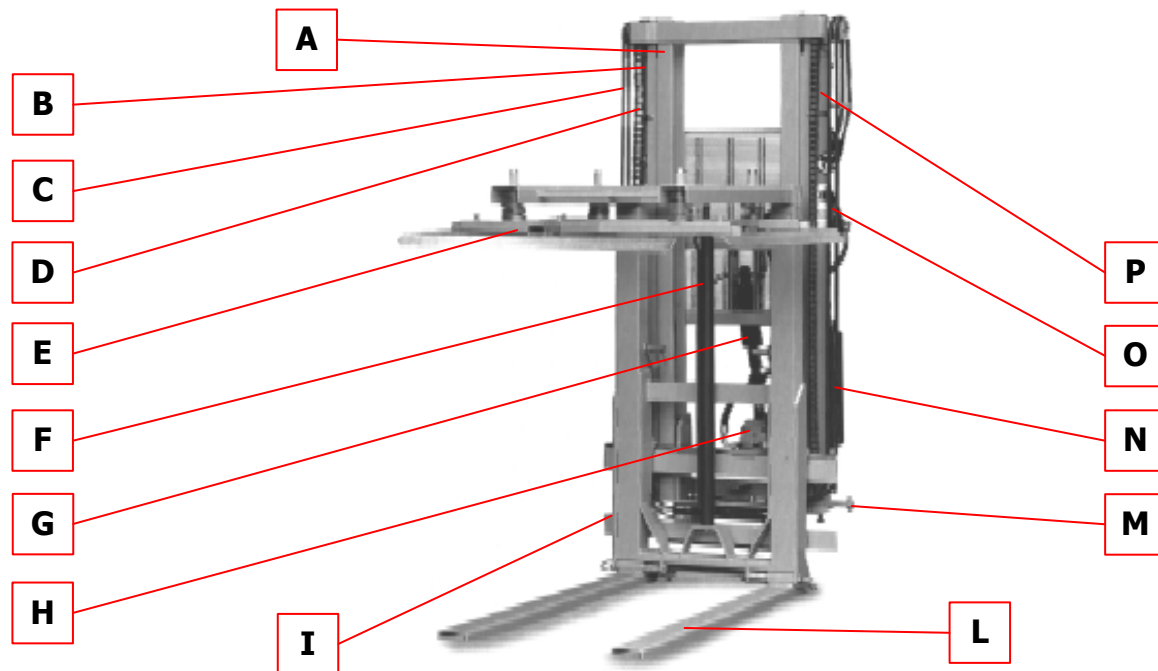

A typical machine consists of the following parts:

A – Internal mast (1 for duplex, 2 for triplex, 3 for quadruplex)	H – Booster-pump assembly (optional)
B – External mast	I – Carriage
C – Hydraulic hoses	L – Folding forks
D – Lift chains	M – Forklift attachment pins
E – Load clamp (optional)	N – Tank (optional)
F – Clamping cylinder (optional)	O – Distributor
G – Tilt cylinder	P – Lift cylinders

Optional equipment:

- Load clamp
- Clamping cylinder
- Booster-pump assembly
- Tank

1.7 DESCRIPTION OF THE MAIN COMPONENTS

MASTS: These make up the hydraulic forklift's framework: the external one is fixed while the internal one slides so that the forks attached to the carriage are able to reach the required height.

HYDRAULIC HOSES: These hoses deliver oil from the point in which it is stored (tank or tractor guard) to the hydraulic cylinders.

BOOSTER-PUMP ASSEMBLY: This unit is directly attached to the tractor's power take-off reaching a max. speed of 570 rpm. It allows the distributor and therefore all the cylinders to be supplied independently without having to use the tractor's quick-connect hitches.

DISTRIBUTOR: The distributor is the forklift's control center; the cylinders required to perform the desired movement are actuated by the levers when necessary.

CYLINDERS: These are the final part of the hydraulic system. The parts connected to them are driven thanks to the pressure exerted by the hydraulic oil inside them.

CHAINS: These devices are used to lift the load into the transmission position in relation to the lift cylinder.

FORKS: These devices engage and sustain the load.

LOAD CLAMP: This device firmly secures the load by means of the pressure exerted by a movable support on the top of the load itself.

1.8 AIRBORNE NOISE LEVEL

Based on the measurements taken in the various positions examined in all machine models, the airborne noise level of the hydraulic forklift on its own is well below the noise emitted by the tractor that actuates it. In any case it is below 70 dB.



CAUTION!

Regular cleaning, maintenance and lubrication play key roles in reducing the airborne noise level of the machine.

1.9 STORING – GARAGING

If the machine is not used for long periods of time, it should be stored in an area that assures protection from atmospheric agents and protected to avoid damage. Before garaging, accurately clean the entire machine and lubricate all the mechanical parts to protect them against rust.

Follow the directions given below before storing the machine:

- inspect the machine to identify any structural damage, scratches in the coating;
- replace any worn or damaged parts;
- carefully wash and dry the hydraulic forklift;
- make sure the safety decals are in place, in good condition and readable (see paragraph 2.3 in this manual);
- check and tighten the screws and bolts;
- grease all the mechanical parts in the spots equipped with grease fittings and the slideways;
- place the machine in a covered area, if possible, on a flat surface (see paragraph **5.1 Hydraulic forklift stability**) and cover with a sheet of breathable material.

Used oil must be collected. Legislation classifies used oil as hazardous waste and as such it must not be disposed in the environment. Used oil must be brought to authorized collection centers. Contact the nearest consortium for waste oil (**C.O.O.U.** - Obligatory Consortium for Waste Oil – **toll free number 800 863 048**).

Heeding the directions given above will extend the service life of the hydraulic forklift as well as assure operator safety.

1.10 PUTTING THE FORKLIFT BACK INTO OPERATION

After the machine has remained inoperative for an extended period of time, make the following checks before putting it back into operation:

- make sure the machine is not damaged;
- make sure there are no deep scratches in the coating or oxidized or rusty parts;
- verify that the mechanical parts are in good condition and work efficiently;

- check and tighten the screws and bolts;
- make certain the hydraulic circuit's tubing has no cracks or cuts;
- make sure the connecting cables are in good condition and the insulation is not ruined (for models equipped with solenoid valves);
- check the oil level in the hydraulic circuit (for models equipped with hydraulic pump and oil tank);
- make certain all moving parts and slideways are accurately greased;
- make sure the safety devices and guards are in good condition and correctly positioned;
- make certain all the safety decals are provided and clearly readable (see paragraph 2.3 in this manual).

1.11 DISPOSAL

If the machine is to be disposed at the end of its service life, it should be taken to an authorized waste collection center observing regulations in force in the country in which the machine is used. Separate plastic and rubber parts and electric and electronic components and bring them to authorized collection centers.

Used oil must be collected. Legislation classifies used oil as hazardous waste and as such it must not be disposed in the environment. Used oil must be brought to authorized collection centers. Contact the nearest consortium for waste oil (C.O.O.U. – **Obligatory Consortium for Waste Oil – toll free number 800 863 048**).

Never:

- Dispose the forklift or parts of it in the environment.
- Dispose oil or lubricants in the environment.
- Leave the forklift in conditions potentially dangers for people and/or things.



THE SAFETY GUIDELINES GIVEN BELOW SERVE TO SAFEGUARD YOUR WELL-BEING. THOROUGHLY READ, UNDEstand AND FOLLOW THEM AT ALL TIMES.

2 SAFETY GUIDELINES

When operating the machine, making the periodic checks and performing maintenance, always observe all current safety standards.

Failure to heed safety standards and precautions may lead to accidents when operating, performing maintenance and repairing the machine.

The C.M. hydraulic forklifts are designed and constructed to lift, transfer and store crates, pallets and bins containing agricultural products. Any other use must be explicitly authorized by the manufacturer in writing.

The manufacturer shall not be held liable for any consequential damage or personal injury resulting from modifications made to the machine not duly authorized with prior written consent.



CAUTION!

C.M. srl shall not be held responsible for any property damage or personal injury deriving from unintended, inappropriate or misuse of the machine or failure to heed the instructions given in this Operation and maintenance manual.

Most accidents that occur when using these kinds of machine are caused by failure to heed the most basic safety precautions and guidelines.

It is therefore extremely important to be fully aware of the potential risks posed when using this equipment and pay careful attention to any actions taken or maneuvers performed whenever operating, performing maintenance and making repairs.

The machine must be used only by authorized personnel who have been properly instructed and trained and fully understand the operating principle and hazards.

Please contact the technicians at **C.M. srl** directly regarding any doubts or questions you may have (refer to page 8 in this manual).

Before attempting to start the machine always:

- thoroughly read and become familiar with the content of this manual.
- study current standards in force regarding the type of work to be carried out.

Always review the most important points before using the machine.

If you sell your hydraulic forklift, this manual must be given to the new owner. The manual is a fundamental part of the machine and must accompany it throughout its service life.

All the instructions contained herein must be closely followed.

2.1 OPERATOR REQUIREMENTS

Both occasional and routine operators who use the C.M. hydraulic forklift must meet the following requirements:

Physical:

Good eyesight, good hearing, good coordination, able to safely perform all the required operations as stated in this manual.

Mental:

Capable of comprehending, understanding and observing all the established safety precautions, safety rules and standards.

The individual must be very alert and vigilant at work, use good judgment concerning his/her own safety as well as the safety of others and be committed to performing his/her tasks in the best possible way.

Training:

The individual must read and understand the content of this manual, the diagrams provided, plates and safety and warning decals. The individual must be qualified and properly trained to work correctly.

Legal:

The individual should possess the specific licenses, where required.



IMPORTANT INFORMATION

The operator may have to possess a particular license, depending on the country in which the machine is used; contact competent authorities to obtain detailed information.

Always wear protective clothing and all the required personnel protective equipment for the job whenever operating, performing maintenance, transporting and making repairs.

In particular, the following equipment should be used:



Work gloves



Work clothes



Protective footwear



Hearing protection



CAUTION

Use only material affixed with the $\text{C}\epsilon$ mark and in good condition.

2.2 ACCIDENTAL PREVENTION AND SAFETY STANDARDS



WARNING!

Carefully inspect the machine before attempting to use it.

Before starting and operating the machine, become familiar with all the devices, controls and functions: thoroughly read this manual.

- The safety symbols provided on the machine provide important information: they must be followed for your own safety. Make sure all the safety pictograms are readable. Clean and replace them with new decals (see paragraph 2.3 in this manual).

- Before attempting to use the machine make sure all the safety devices and guards are correctly positioned and integral. If the protective devices are faulty or damaged, replace them without delay.



WARNING!

Always verify that no people or animals are within the range of action of the machine before starting operation.

- The manual must always be close at hand so that it can be consulted to check operation. If lost or ruined, contact **C.M. srl** to get a replacement copy.
- Do not wear any loose or hanging clothes or other items that may be caught in moving machine parts (unbuttoned cuffs, belts, necklaces, bracelets).



When operating, performing maintenance, making repairs, transporting or storing the machine always wear safety shoes, protective overalls, work gloves and, hearing protection, if necessary.

- If the equipment has to be assembled on site, get a flat, compact area read that is large enough.
- Establish the best position in the work area.
- Never operate the machine if you are tired, ill or under the influence of alcohol, narcotics or certain prescription drugs that impair judgment, alertness or coordination.
- Always work with good lighting: never operate the machine under conditions in which visibility is poor.
- Lift equipment suitable for the weight to be unloaded and loaded on the machine must be used (see chapter **3 Shipment**).
- When the equipment is running, it is forbidden to go within the forklift's range of action: stay at least 20 m away.

- Keep the work area as neat and orderly as possible. Do not leave objects around that may obstruct the tractor or cause accidents.
- While working, the operator must have a clear view of work areas deemed dangerous.
- Be careful not to damage things and the environment.
- The operator must constantly supervise the load lifted by the forklift and work area. A signalman should be present, if necessary (using the hand signals set forth in Directive 92/58/EC).
- It is severely forbidden to walk and/or stand underneath the forklift's forks.
- Before using the hydraulic forklift:
 - Make sure autonomy is sufficient in order not to have to stop the machine during work or critical stages.
 - Make certain the periodic maintenance operations have been carried out as directed in chapter **11 Maintenance**.
 - Do not make make-shift repairs in order to start work.
- All maintenance, repairs, checks and adjustments to the forklift can be made only if the engine is shut off, the forks are on the ground making sure the machine is stable and cannot roll over.
- Make sure a first aid kit is readily available at the work site.
- Make certain the machine did not incur any damage during transport. If damage is found, contact C.M. srl immediately.
- Keep the machine free of extraneous materials (debris, tools, various objects) that may compromise performance or cause operator injury.



DANGER!

Do not allow anyone to get on the machine or carry riders.

- Park the machine on firm level ground making sure it is steady and stable.
- Check wear and tear of the hydraulic hoses. Replace them if worn.



WARNING!

NEVER walk and/or stand underneath the forks regardless of whether or not the load is suspended!!!

- Barricade the work area to prevent access by unauthorized persons using barriers and alert symbols.
- Any modifications made to the machine by the user may compromise safety. In this case, the user is the only person responsible for any accidents that arise.
- When performing maintenance or adjusting parts of the equipment, never use your hands to do any jobs for which specific tools exist.
- Do not use tools that are in poor condition or inappropriately.
- If the hydraulic hoses are detached for any reason, always verify that they are properly connected before pressurizing the system.
- Make sure no tools or other items have been left inside the machine after performing maintenance and making repairs.
- While maneuvering, it is forbidden to give hand signals and instructions at the same time to other people. **Instructions must be given to just one person.**
- Do not scare or call the operator's attention unless absolutely necessary. No horse-playing or joking around while using the machine.
- Always go up and down slopes with the load upstream.
- While lifting the load, the forks must be in the center. The transfer device can be used only with the means stopped and load in place.
- The tipper should be forward only when the means is parked on solid ground.

- When transferring, keep the load 20 – 30 cm off the ground with the forklift facing the operator:
 - Operate at low speed
 - Do not operate on cross slopes
 - Do not operate the transfer device
 - Keep the load at the back of the forks
- Never do any work, maintenance or repairs while the tractor is running and under poor lighting conditions.
- Before working on the hydraulic lines, depressurize the line to avoid contact with hot oil.
- Never leave the machine unattended in a dangerous position.

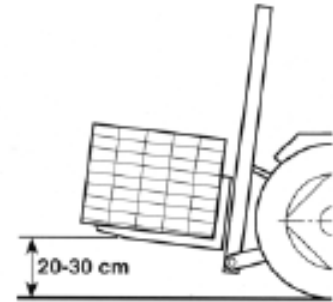

	<p>WARNING!</p> <p>Always verify there are no overhead power lines within the range of action of the machine.</p>
--	---

- When the machine is not working, park on flat ground, shift to 1st gear, shut off the engine, activate the parking brake and lower the forks to the ground.
- Do not use open flames in areas where fires or explosions may occur.

The operations to mount and dismount the forklift from the tractor, setting the devices and required adjustments must be carried out by just one operator who will leave the control post after assuring no maneuvers can be performed.

2.3 SAFETY SYMBOLS

CAUTION!



Make sure the safety pictograms are readable. Clean them with water, soap and a cloth. Replace any ruined decals putting the new ones back into the same exact position as described below.

If necessary, order them from the manufacturer, dealer or authorized service center.

2.3.1 Description of the pictograms



1. **CAUTION** – Read the Operation and maintenance manual in its entirety prior to operating the machine.



2. **CAUTION – WARNING**. Keep a safe distance away.



3. **CAUTION** – Falling **HAZARD**. Do not allow anyone to get on or carry any passengers.



4. **CAUTION – HAZARD** of falling from above and crushing. Keep a safe distance away.



5. **CAUTION** – Crushing **HAZARD**. Keep your hands a safe distance away.



6. **CAUTION** - Crushing **HAZARD**. Keep your lower limbs a safe distance away.



7. Lift point.

2.3.2 Location of the pictograms on the machine



3 SHIPMENT

The machine must be loaded on suitable means for shipment. Exercise extreme caution when loading and unloading. These operations can be performed only by qualified personnel (forklift truck operators, slingers, etc..).

If lifted, the size of the equipment used to handle the machine must be adequate for the weight involved, taking into consideration the weight given on the nameplate attached to the hydraulic forklift.

Raise the hydraulic forklift and hook the lift points A (following figure) marked with symbol  (see paragraph **2.3 Safety symbols**).

During shipment, the machine should be secured in place with ropes or cables attached to the points found at the ends of the loading platform.

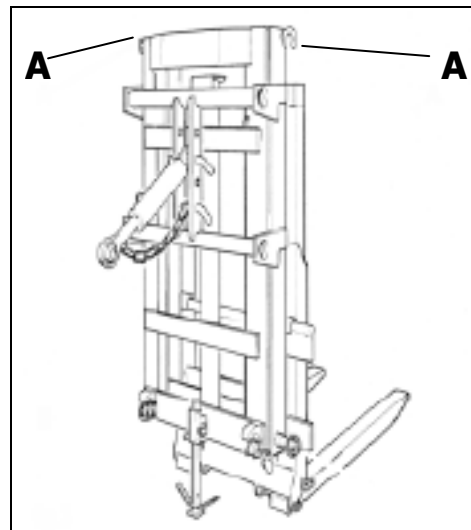

4 MOUNTING THE HYDRAULIC FORKLIFT ON THE TRACTOR

4.1 TRACTOR FEATURES

The hydraulic forklifts constructed by **C.M. srl** are designed for application on any type of farm tractor provided that they match the power requirements given in the technical specifications charts in par. **1.5** in this manual.



WARNING!

Mount the hydraulic forklift only on agricultural tractors and rollover protective structures (ROPS) and falling object protective structures (FOPS).

The tractor must satisfy the following requirements in order to mount the C.M. hydraulic forklift:

- Lift with universal three-point hitch.
- 540 rpm power take-off if the hydraulic pump assembly is installed (see chapter **13 Interchangeable equipment**).
- Hydraulic system with at least 40 l/min delivery rate and operating pressure of at least 140 bar.

The weight of the tractor + hydraulic forklift assembly must be distributed in order to assure stability as stated in chapter **5 Stability**. The tracks of the tractors should be set to the maximum width to improve side stability.

4.2 MOUNTING

When first mounting the hydraulic forklift, some adjustments have to be made which require lifting the machine. As a result, lift equipment whose capacity is not less than the weight of the empty machine is required. Secure the lift equipment to the hooks **A** (following figure) to handle the forklift in the best possible manner.

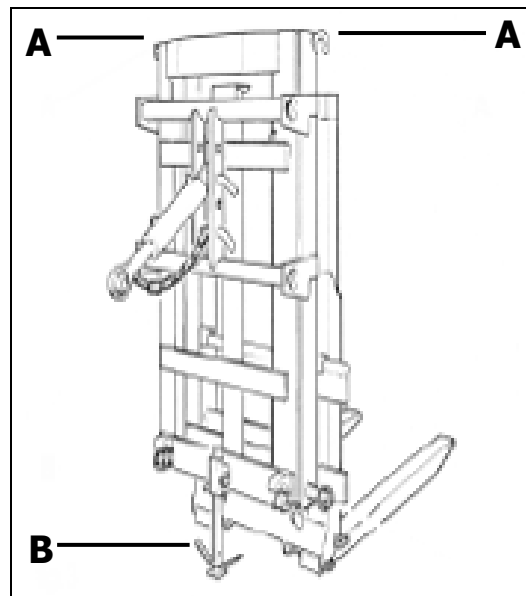

As regards tractors equipped with a universal three-point hitch either at the front or back, follow the directions given below to install:

1 When installing the first time, set up the hydraulic forklift attached to the lift equipment at the front of the tractor.

When installing there after, bring the tractor near the parked forklift as directed in paragraph **1.9 – Storing – garaging**.

2 Completely lower the tractor's lift arms and slowly approach the forklift.

3 Insert the ball joint of the tractor's lift arm in the lower pin C of the hydraulic forklift (figures below) being careful to secure it with the safety dowels provided.

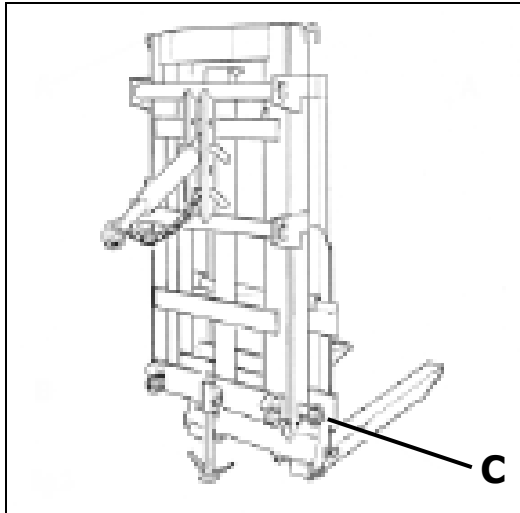

4 Connect the forklift's tilt cylinder **D** (figure below) to the top of the third point of the tractor and secure with the safety dowel provided with the tractor.



IMPORTANT INFORMATION

If necessary, use the lift equipment to bring the hydraulic lift near the tractor.



CAUTION!

The position in which the tilt cylinder is hitched to the farm tractor is to be adjusted according to the recommended angle of incidence which is approximately **20 – 30°**.

The plate of the forklift's third point has four holes to permit optimal adjustment (following figure).

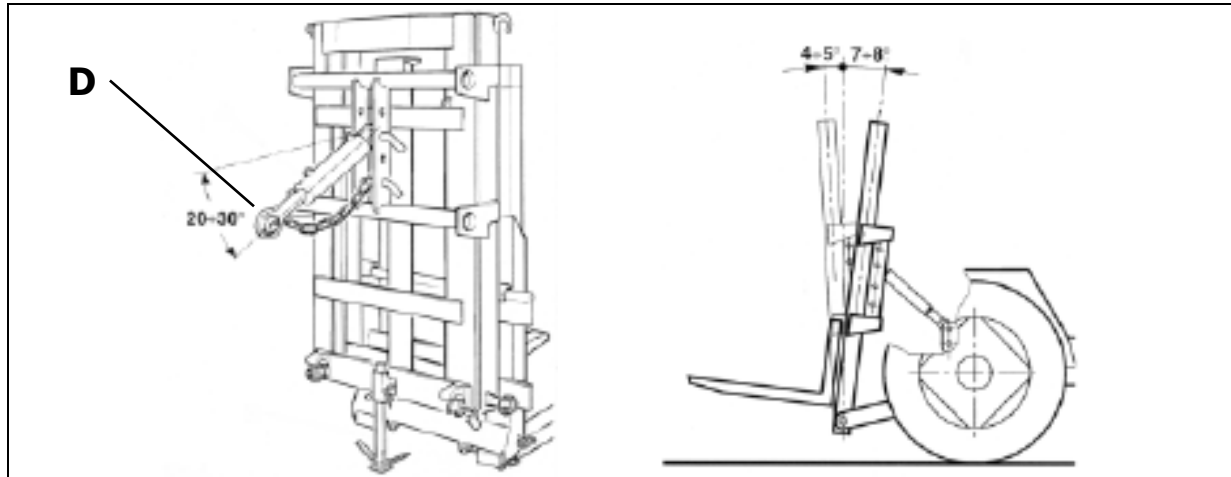

5 With the tilt cylinder fully retracted, select the most suitable mounting hole in the tractor so that the forklift is positioned as illustrated (previous figure):

- Towards the operator, tractor side **7 – 8°** max.
- Tilted forward, cylinder fully extended, **4 – 5°** max.

6 Connect the safety chain **E** in one of the holes available in the tractor's third point (following figure) to prevent forklift rollover in the event that the tilt cylinder breaks.

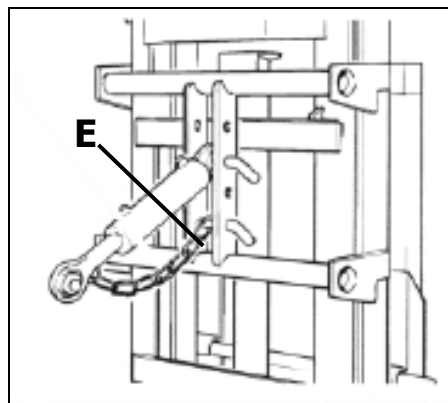

CAUTION!

When the tilt cylinder is fully extended, the chain should not be tight. In fact, the forklift should be able to move a few centimeters.

7 Block the tractor's lift arms with the chains and tie rods which the arms are usually provided with.



WARNING!

It is extremely important to secure the lift's arms to avoid dangerous shifting or shaking.

8 Raise the arms of the tractor's lift a few centimeters so that the stabilizer foot can be moved into the rest position. Firmly secure by placing the cotter pin or dowel provided in the highest hole in the foot holder.

9 Lower the lift's arms again and **secure the actuating lever.**



DANGER

It is fundamental to secure the lever of the tractor's lift to prevent the hydraulic forklift from rolling over against the cab or tractor's roll-bar.

Never use the tractor's lift to aid in lifting!



WARNING!

Always verify that the connecting pins have a safety cotter pin and that it has been correctly inserted.



WARNING!

Always verify that no people or animals are within the range of action of the machine before starting operation.

4.3 HYDRAULIC CONNECTIONS

In order for the hydraulic forklift to work properly and obtain the required performance, its hydraulic system has to be connected to the tractor's.

The quick connect couplers of the tractor from which the forklift directly receives oil or a pump-booster assembly on the 540 rpm power take-off can be used for this purpose.

In the latter case, the oil is supplied from the tank provided with the forklift (see chapter **12 Accessories**).

4.3.1 Connection to the tractor's quick connect couplers



IMPORTANT INFORMATION

If the forklift needs to be connected to the tractor's hydraulic system, it is fundamental to verify a distributor with double-acting lever possibly with a retaining system is available.

C.M. srl supplies distributors designed for tractors with open-center distributors; if tractors with closed-center distributors are used, it must be specified when placing the order.



CAUTION!

Carefully check in which direction the lever has to be actuated so that pressurized oil is present in the quick-connect coupler which the delivery line of the forklift's distributor will be connected to.



CAUTION!

If the tractor's lever is actuated in the wrong direction, i.e. sending pressurized oil into the discharge side of the forklift's distributor may cause serious damage to the hydraulic system.

Once the tractor's pressure tap has been located (by carefully reading its Operation and maintenance manual), proceed as follows:

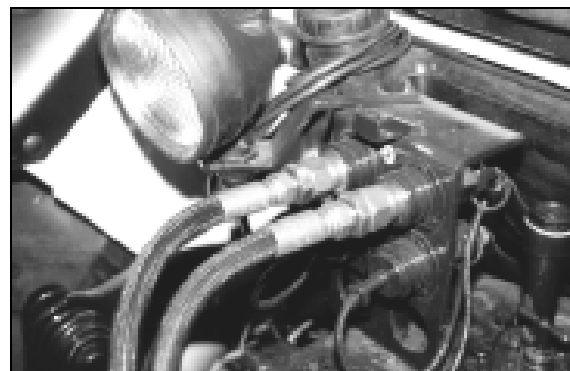
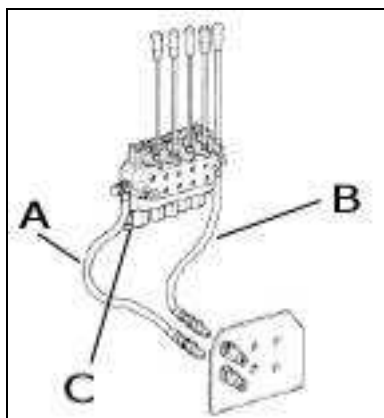

- 1** Connect delivery hose **A** (previous figure) for the forklift's distributor (side on which pressure relief valve **C** is found) to the tractor's oil delivery quick connect coupler.
- 2** Connect discharge hose **B** (previous figure) for the forklift's distributor to the tractor's other quick connect coupler.
- 3** Actuate the tractor distributor's lever to deliver oil and then secure it so that a continuous flow is delivered to the forklift.



IMPORTANT INFORMATION

Before connecting the quick connect couplers, remove any dust or debris present on them.

Always discharge the hydraulic system before attempting to disconnect and connect the quick connect couplers.

In the event of contact with the hydraulic oil, thoroughly wash with soap and water.

4.3.2 Connecting the pump-booster assembly to the tractor



IMPORTANT INFORMATION

When the forklift needs to be connected to the tractor with the pump-booster assembly, always verify the tractor has a power take-off set to 540 rpm.

C.M. srl supplies pumps with delivery rates ranging from 14 to 20 liters/min together with boosters with 3.5:1 ratio.

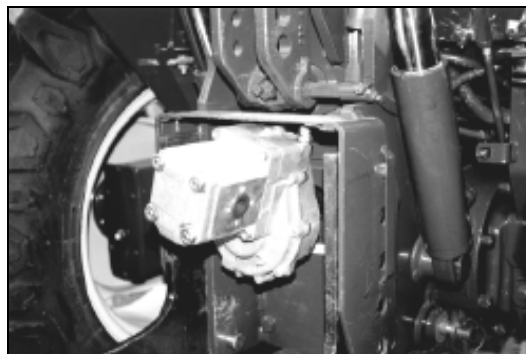

In particular, 3 types of hydraulic tanks are available:

- Small: 7 liter capacity, designed for forklifts up to 9 tons
- Medium: 10 liter capacity, designed for forklifts up to 16 tons
- Large: 15 liter capacity, designed for forklifts up to 20 tons

The filler plug has a dipstick to check the oil level in the tank.

1 Connect the pump-booster assembly (following figure) to the tractor's power take-off.

2 Secure the clamp present on the booster (figure below) with the chain provided to prevent the entire assembly from turning when inserted in the power take-off. Leave the chain loose.

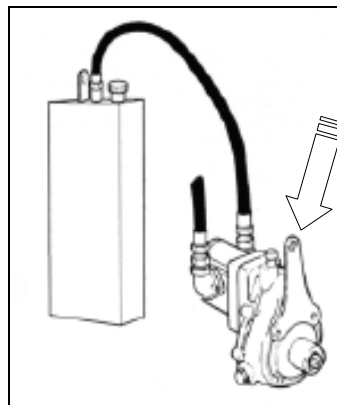

4.3.3 Hydraulic connection to tractor with cab

If the forklift is to be attached to tractors with cabs, clearly specify it at the time of order so that hydraulic hoses or flexible controls long enough to install the distributor inside the cab are provided.



Follow the directions given below for hydraulic connections:

1 Place the forklift's distributor inside the driver's cab (previous figure). Secure in a position that is comfortable and ergonomically correct for the operator. Make sure all the safety devices and guards required by current laws and supplied with the forklift are installed.



CAUTION!

When the distributor is installed inside the cab it should not obstruct the other controls or create additional hazards.

If present, secure the distributor to the tractor's bayonette fitting provided to fix the lever of the trailer's parking brake. **C.M. srl** supplies a complete kit already ready for distributor installation in the cab for most tractors available on the market.

2 Try to arrange the bundle of hydraulic tubes so that they cannot get caught in mechanical parts, are not twisted and, above all, do not ruin the cab compromising performance (figure below).

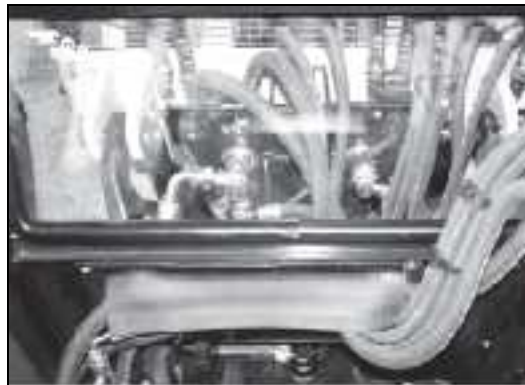

3 Connect the forklift as directed in paragraph **4.3.1** or **4.3.2**.

4.4 MOUNTING THE FORKLIFT WITHOUT ITS OWN DISTRIBUTOR

In order to install hydraulic forklifts not equipped with their own hydraulic distributor, the tractor which it is mounted on must have an auxiliary distributor.

In this case, the fitter and user must carefully examine and determine the connections required and how to make them. This should be done by checking the controlled movements and how the machine responds under safe conditions making sure there are no bystanders and testing movements with the machine unloaded.

4.5 INSTALLING THE DOUBLE TIPPER KIT

The C.M. hydraulic forklift can also be installed on farm tractors that do not have a three-point hitch.

WARNING!



The C.M. hydraulic forklift is designed and constructed and carries the CE mark in its standard configuration (see paragraph 1.5 and 1.6). Any individuals who make modifications or connections different from those illustrated in paragraphs 4.1 – 4.4 are responsible for conducting a new risk analysis, performing new inspection and testing and affix the CE mark on the new machine resulting from the changes.

To connect, obtain the double tipper kit (see chapter **12 Accessories** and the figure to the side) from **C.M. srl**. The kit includes two hydraulic cylinders with safety chain and relative hydraulic connections which represent the connection interface on the forklift side.

On the other hand, as regards the tractor side, the fixed support brackets are not supplied by **C.M. srl** as they vary according to the model of the farm tractor to be connected.

As a result, it is not possible for **C.M. srl** to include this type of connection to the tractor in its risk analysis and CE marking: these are at the expense of the fitter who installs the machine on his own tractor. This individual should contact



the tractor manufacturer and/or competent technical body for authorizations, tests or inspections.

	<p>IMPORTANT INFORMATION</p> <p>When installing the double tipper kit, always consult the Installation manual provided by the individual who affixes the new CE mark.</p>
---	---

5 STABILITY

5.1 HYDRAULIC FORKLIFT STABILITY

The term stability refers to the machine's capacity to remain in a steady and stable position when parked after being dismantled from the farm tractor.

Place the hydraulic forklift vertically on a level compact surface. Place it on the ground being careful to lower the foot **B** (figure below) in order to assure stability of the forklift.

It is strongly recommended to park the forklift inside a protected area to prevent unauthorized persons from going near the machine.

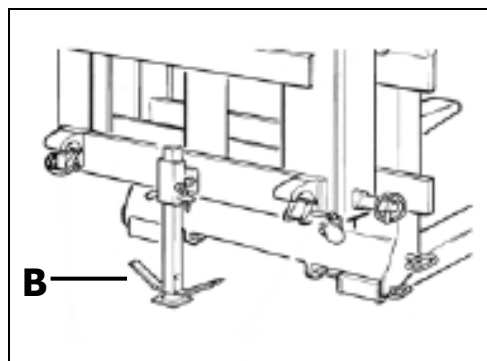

5.2 UNIT STABILITY AND BALLASTING

The weight of the machine alters stability of the tractor + hydraulic forklift unit affecting steering and braking capacity. For this reason it is important to work at low speed.

In particular, it is good practice to make sure the front axle always rests on a load equal to at least 20% of the weight of the tractor + trailer unit.

Carefully evaluate the entity and distribution of the loads, using additional ballast if necessary, as shown below.



DANGER!

Attaching towed equipment causes the loads on the tractor's axes to shift: this may cause rollover.



IMPORTANT INFORMATION

Before installing, always consult the Operation and maintenance manual that deals with the tractor to evaluate the weights that can be applied on the axles and tires installed.

If in doubt, contact the technicians at C.M. srl.

The farm tractor + hydraulic forklift assembly is illustrated in the diagram below:

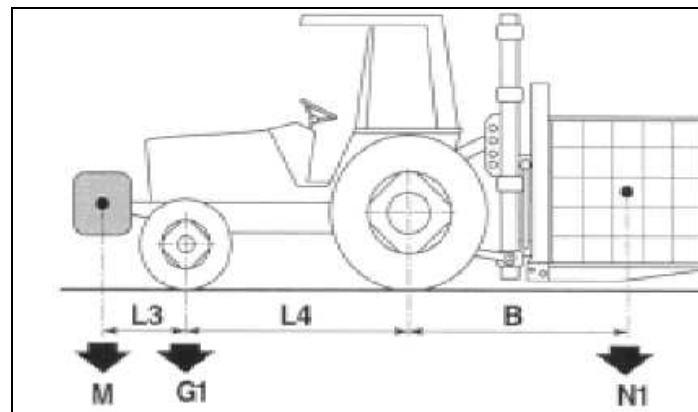

Where:

M = weight, expressed in kg, of the ballast to be mounted at the front of the tractor

N1 = max. load, expressed in kg, that can be applied on the forklift (→ par. **1.5 Technical specifications**)

G1 = weight, expressed in kg, applied on the front axle without ballast and with the hydraulic forklift mounted

B = horizontal distance, expressed in mm, between the center of gravity of the load and rear axle of the tractor

L4 = tractor step, expressed in mm

L3 = horizontal distance, expressed in mm, between the center of gravity of the front ballast and front axle of the tractor

In order to assure trouble-free motion, ALWAYS remember to lock the tractor's lift bars to avoid sideshifting compromising crosswise stability of the unit.

An empirical formula to determine the type of ballast to be mounted at the front of the tractor is given below in reference to the previous figure:

$$\begin{array}{cc} \mathbf{N1 \times B} & \mathbf{0,66 \times (G1 \times L4)} \\ \textit{First term} & \textit{Second term} \end{array}$$



IMPORTANT INFORMATION

After calculating, if the *first term* is less than or equal to the *second term*, it is possible to work without a ballast; on the other hand, if the *first term* is greater than or equal to the *second term*, a ballast must be mounted on the tractor before performing any operations, referring to the formula given below:

$$M \geq \frac{N1 \cdot B - 0,66 \cdot (G1 \cdot L4)}{L3 + L4}$$



DANGER!

Always firmly secure the ballast and never use make-shift devices in order to work.

6 CONTROLS

6.1 HYDRAULIC DISTRIBUTORS

6.1.1 Standard hydraulic distributor

An hydraulic distributor is mounted in a vertical position on the forklift to control the cylinders employed for movements.

The standard version comes with a 4-element distributor (following figure), whose functions are described below:

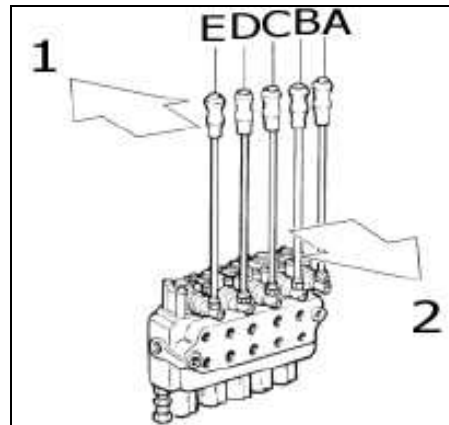

1 = Towards load
2 = Towards operator

Lever A: Function: **Tipping** (tilting the forklift forward or backward)

A1 Tipper forward



A2 Tipper return (towards forklift)



Lever B: Function: **Lift** (movement of forks)

B1 Forks down



B2 Forks up



Lever C: Function: **Side travel**

C1 Fork movement to left (operator sitting on tractor)

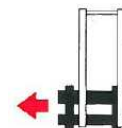

C2 Fork movement to right (operator sitting on tractor)

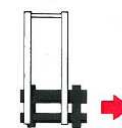

Lever D: Function: **Load clamp** (when provided) or interchangeable equipment (see chapter **13 Interchangeable equipment**)

D1 Clamps load



D2 Releases load



On request, a 5-element distributor can be installed on C.M. forklifts in order to actuate interchangeable equipment (see chapter **13 Interchangeable equipment**); the additional lever serves only for the services.

Lever E: Function: **Services**

E1 Tilts load downwards (away from operator)

E2 Tilts load towards operator (tractor

Consult the Operation and maintenance manual for the interchangeable equipment for information about the connections and operating mode.

6.1.2 Remote hydraulic distributor

When the hydraulic forklift is mounted on tractors equipped with a cab, a remote distributor is installed in a horizontal position. It has the same features and functions in the same way as the standard distributor described in paragraph 6.1.1.

6.1.3 Tractor auxiliary distributor

In order to mount the hydraulic forklift in the version not equipped with its own hydraulic distributor, the farm tractor which it is attached to should have an auxiliary distributor.

In this case, the fitter and user must carefully examine and determine the connections required and how to make them. This should be done by checking the controlled movements and how the machine responds under safe conditions making sure there are no bystanders and testing movements with the machine unloaded.

6.2 ELECTROHYDRAULIC DISTRIBUTORS

These kinds of distributors allow the forklift to be remote controlled without however having any bulky bundles of tubes in the way. This is accomplished by using just one wire that runs from the tractor's electrical outlet.

These applications are particularly indicated for tractors with cabs as the cab can be kept close without losing the advantages.

6.2.1 Selector with electro-hydraulic control monolever



IMPORTANT INFORMATION

If this type of device is used, the forklift is supplied with:

- Electrohydraulic distributor
- Single control lever
- Complete electrical system.

Follow the directions given below to install:

- Secure the monolever on the tractor distributor's lever corresponding to the hydraulic outlets used to supply.
- Fissare la monoleva sulla leva del distributore della trattore corrispondente alle prese idrauliche usate per l'alimentazione.
- Supply the distributor with the quick connect couplers as directed in paragraph **4.3 Hydraulic connections** in this manual.
- Insert the electric plug into the tractor's socket.
- Check operation and performance.



WARNING!

Connect the forklift's electrical system only to tractors with a 12 Vdc system.

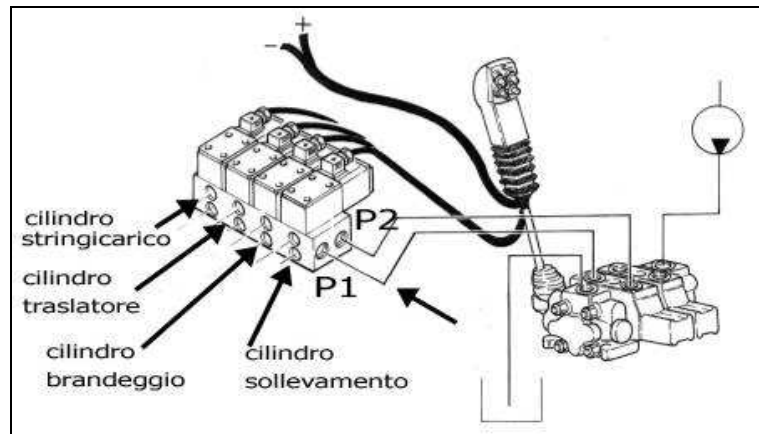

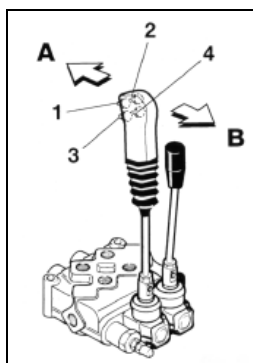

Clamping cylinder - Transfer cylinder - Tilting cylinder - Lift cylinder

Operation of the electro-hydraulic monolever takes place only when one of the buttons is pressed (moving the lever will not have any effect on the hydraulic forklift). It is summarized below:

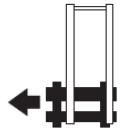
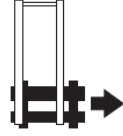

Position	Button	Action	Symbol
A	1	Forklift down	
B	1	Forklift up	
A	2	Tipper forward	
B	2	Tipper back (return)	

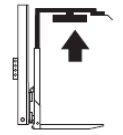
A	3	Travel to left (operator on tractor)	
B	3	Travel to right (operator on tractor)	
A	4	Clamp down (closed)	
B	4	Clamp up (open)	

6.2.2 Distributor with electric control panel



IMPORTANT INFORMATION

If this type of device is used, the forklift is supplied with:

- Electrohydraulic distributor
- Electric control panel complete with hermetic levers.

Follow the directions given below to install:

- Attach a plug to the control panel's power cord that can be plugged into the tractor's socket.
- Secure the control panel inside the driver's cab in a position convenient and comfortable for the operator.
- Supply the distributor with the quick connect couplers as directed in paragraph **4.3 Hydraulic connections** in this manual.

- Insert the electric plug into the tractor's socket.
- Check operation and performance.



WARNING!

Connect the forklift's electrical system only to tractors with a 12 Vdc system. The electro-hydraulic distributor is designed for an open-center supply system.

Operation of the electrical control panel is summarized below:

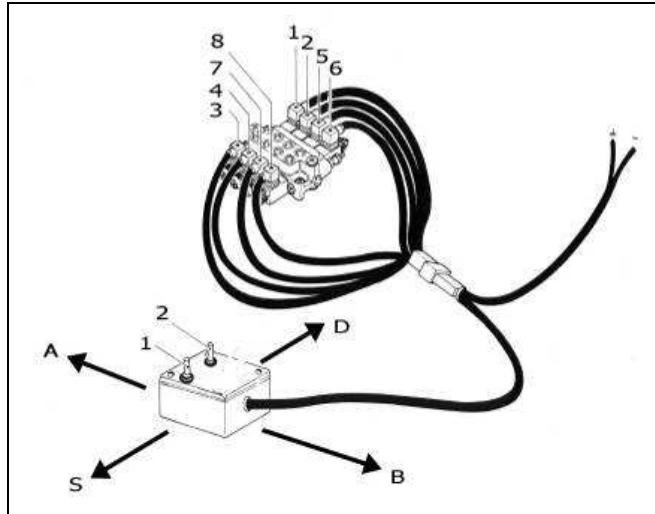

The switches are moved in the direction indicated by the arrow. The forklift performs the desired movement according to the direction in which the switches are turned.



WARNING!

If movements do not take place in the desired direction, reverse the position of the solenoid valves for the same distributor element.

Position	Solenoid valves connected	Action
1	5 - 7	Lift
	2 - 4	Tipper
2	1 - 3	Transfer device
	6 - 8	Load clamp

Position	Button	Action	Symbol
A	1	Forklift down	
B	1	Forklift up	

S	1	Tipper forward	
D	1	Tipper back (return)	
A	2	Clamp down (closed)	
B	2	Clamp up (open)	
S	2	Travel to left (operator on tractor)	
D	2	Travel to right (operator on tractor)	

7 CHECKS AND ADJUSTMENTS

7.1 CHECKS



WARNING!

Before attempting to start work, ALWAYS visually inspect. If problems are found, remedy them immediately and contact the manufacturer, if necessary. Do not start up the machine until all the problems have been cleared.

Before starting work:

1. Read and understand the Operation and maintenance manual and all the safety decals.
2. Do not operate the machine whenever a safety device or guard is damaged or has been removed.
3. Keep hands, feet, clothes and hair away from rotating parts.
4. No passengers allowed. Do not carry passengers anywhere on the machine.

5. Clear the area, Ensure that all bystanders, particularly children are at a safe distance before starting up.
6. Prior to start up, make sure all the screws, bolts, nuts and other fasteners are tight.
7. Do not perform any operations when there are leaks in the hydraulic system.
8. Before attempting to pressurize the hydraulic system, make sure all the components are tight and that the tubes, fittings and joints are in good condition.
9. Visually inspect the machine prior to start up.
10. Check wear and tear of the lift chains as directed in paragraph **11.1 Maintenance chart**.
11. Make sure the parts shown in the diagram in paragraph 11.1 are adequately lubricated.
12. Check the level in the oil tank (if present);
13. Check the level in the booster (if present);
14. Inspect the hydraulic hoses (water-proofness and porosity): any leaks in the hydraulic system must be immediately remedied.
15. Before attempting to start up the tractor, visually verify that the stabilizer foot is raised in the transfer position and firmly locked in place.



CAUTION!

Before attempting to use the machine, make sure there are no people or animals present within a 20 meter radius.

Make certain that all the machine parts and equipment function properly while working. Keep in mind that most malfunctions and faults that may occur during machine operation result from poor maintenance.

As all the mechanical parts and hydraulic connections undergo a break-in period so that they can “adjust” to one another when the machine is first started up, it is **FUNDAMENTAL** to carefully perform the checks listed below.

After firmly attaching the hydraulic forklift to the tractor and making the hydraulic connections as directed in chapter **4 Mounting the hydraulic forklift on the tractor**, final inspection is required to check and test forklift installation.



IMPORTANT INFORMATION

If the machine works with the pump-booster assembly, engage the power take-off control lever present on the tractor to run the forklift.



DANGER!

Conduct the tests and become familiar with the machine in an open area, away from people and things.



CAUTION!



Always use the required personal protective equipment.

Check the oil level in the tank (see paragraph 11.2.1) (if present) before starting work).

7.2 ADJUSTING THE FORKS

The width of the forks, regardless of their version, can be adjusted to adapt to the size of the load to be lifted.



CAUTION!

Move both forks the same distance so that the load is always balanced.

7.2.1 Adjusting folding forks

Follow the directions given below to adjust the folding forks:

- 1** Remove the dowel **D** (following figure).
- 2** Remove the rear stop pin **A** and pivot pin **C** to disengage the fork **B**.
- 3** Place the fork in the most suitable position, insert the pins and secure with the dowels.

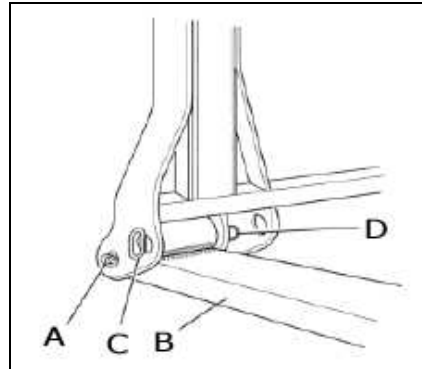

7.2.2 Adjusting the FEM forks

Follow the directions given below to adjust the FEM forks:

- 1** Raise the stop lever **A** (figure to the side).
- 2** Place the fork in the desired work position.
- 3** Engage the stop lever **A**.

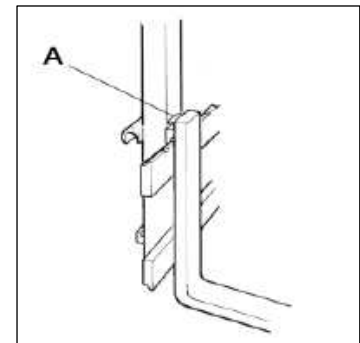

CAUTION!

When engaging the stop lever, make sure it is actually in place on the fork holder; move the fork with your hands to verify it is in place.

7.3 ADJUSTING THE LOAD CLAMP

The side of the load clamp should be adjusted according to the size of the load to be lifted. Proceed as follows:

- 1** Loosen the fixing screws **V** for the sides (figure to the side).
- 2** Move the side until the required width is reached, inserting or removing it.
- 3** Fully tighten the fixing screws **V**.

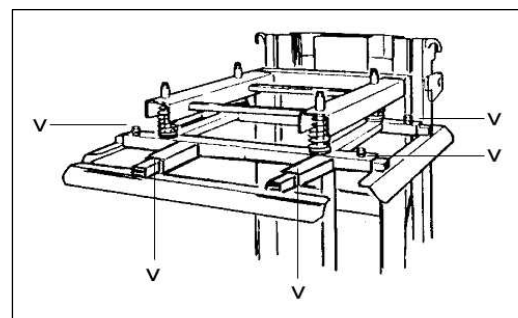

8 OPERATION OF THE HYDRAULIC FORKLIFT

Keep in mind that the hydraulic forklift is designed to lift, handle and store crates, bins and pallets containing agricultural products.

C.M. hydraulic elevators are designed and manufactured to be attached to the back of a tractor or, less frequently, at the front. They are operated by just one operator sitting in the driver's seat.

As far as use of the **load clamping** device is concerned, always observe the following size limits for the load to be handled when the forklift is mounted at the front of the tractor: **1200 mm x 1200 mm base x 1500 mm height**. In exceptional cases when the forklift needs to be used to handle bulky loads or in any case, a single item that is close to the recommended size limits, the clamp can be used. When working under poor visibility conditions a ground signalman using the hand signals set forth in Directive 92/58/EC must be present to give manoeuvring instructions to the operator.

The machine is intended to be used only in the agricultural industry.

In particular, no passengers are allowed. Do not carry passengers anywhere on the C.M. hydraulic forklift.



WARNING!

Learn about all controls and have knowledge of the machine and its workings before operating the forklift machine.



WARNING!

Before attempting to start up the forklift, carefully check it over (see chapter 7 Checks and adjustments).

- Always verify that no people, above all children, or animals are within the range of action of the forklift. When the equipment is being used, it is forbidden to enter the range of action of the forklift. Always keep at least 20 meters away.
- Carefully observe the load limits given on the nameplate and in this manual. Personnel must be adequately instructed and trained.
- Carefully follow all the safety and work procedures.

The hydraulic forklift's work stages are summarized below:

- A Loading**, during which the load is engaged and lifted with the forks 20 – 30 cm off the ground.
- B Handling** during which the load is taken from the pick up area to the work or storage areas.
- C Unloading** during which the load is placed in the work or storage area.

8.1 LOADING STAGE

- 1** Bring the tractor near the load to be handled and stop.
- 2** Place the forklift in a vertical position using the tipper and set the forks so that they can correctly engage the load.
- 3** Center the fork insertion point using the side transfer device and slowly advance until the load is completely engaged.
- 4** Lift the forks a few centimeters until the load is completely on them.
- 5** Secure the load with the clamp if provided.
- 6** Slightly back up to take the load out of the placing area and return the forklift to the tractor with the tipper.
- 7** Lift the load approximately 20 30 cm off the ground.
- 8** Bring the transfer device back into the central position.



DANGER!

Before attempting to handle the load, always evaluate the forklift's load and lift capacity. The loading operation should be done on flat terrain.

8.2 HANDLING STAGE

- 1 Go to the placing area operating the tractor at low speed.
- 2 Do not loosen how the load is secured or tilt the forklift.



DANGER!

While traveling, reduce the speed according to the terrain conditions and visibility to avoid sudden stops or losing the load. Always face slopes with the load upstream. Avoid side slopes. Always travel with the load close to the ground and forklift towards the tractor. Always avoid sudden movements.

8.3 UNLOADING STAGE

- 1 Activate the tractor's brake.
- 2 Go near the unloading point.
- 3 Place the masts in a vertical position.
- 4 Lift the load to a height slightly higher than the placing position (about 10 cm higher).
- 5 Slowly release the brake.
- 6 Center the placing point using the transfer device. Move slowly until the exact position in which the load is to be placed has been reached.
- 7 Tilt the forklift forward and slowly lower the forks to place the load and disengage it.
- 8 Remove the load from the forks and slowly go away until they are entirely free.
- 9 Bring the forks back into the work position.

**DANGER!**

Work on terrains that are as flat and level as possible to avoid rollover.

9 ROAD TRAVEL

As far as road travel is concerned, follow current regulations and the highway code in force in the country in which the machine is used.

The operators must contact competent authorities to get more detailed information.

10 DISMOUNTING THE HYDRAULIC FORKLIFT

When dismantling the hydraulic forklift, the following guidelines and instructions must be followed to avoid risks and problems to the greatest extent possible:

- 1** Select a firm level ground so that the foot completely rests on the terrain. If this cannot be done, place a solid block under the foot.
- 2** Make sure the forks are securely attached with the lock pins.
- 3** Bring the forklift into a vertical position with the forks on the ground.
- 4** Adjust the foot so that it supports the weight of the forklift.
- 5** Disconnect:
 - Lift's arms
 - Tilt cylinder

**CAUTION**

In order to disconnect the lift's arms, use the foot to relieve the weight from the lift's arms.

- 6** Disconnect the quick-connect couplers or pump-booster assembly (if present).

**CAUTION!**

If the forklift works with the pump-booster assembly, once the unit has been removed from the tractor's power take-off, put the safety guard back in place.

Before storing for long periods, follow the directions given in paragraph **1.9 Storing-garaging** in this manual.

11 MAINTENANCE

11.1 OVERVIEW

Regular cleaning and maintenance play key roles in obtaining efficient, reliable and safe operation of the C.M. hydraulic forklift. Good routine maintenance will keep running costs down and while obtaining top machine performance.

It is therefore fundamental to observe the maintenance chart given below (par. 11.1.1) to prevent malfunctions which, in turn, may cause damage and/or injuries.

**WARNING!**

All maintenance jobs, adjustments and repairs must be performed only with the tractor's engine shut off and forks placed on the ground.

Keep in mind that all maintenance jobs must be performed by properly trained qualified personnel with the machine stopped.

The maintenance jobs and repairs should not be done outdoors but in suitably equipped service repair shop.

Before attempting to start maintenance work, perform the following operations:

- always use the required personal protective equipment (work overalls, safety footwear, work gloves);
- use all forms of accident prevention and take all the precautions established for the type of job.

Damaged parts should be replaced and special jobs not dealt with in this manual should be performed only by properly trained personnel. Contact the Customer service department at **C.M. srl** for this purpose.

If pressurized water or compressed air is used to clean the machine, always wear protective glasses or masks and keep people or animals away from the machine. Do not use inflammable fluids.

If high-pressure water is used to clean the machine (pressure washer), never direct the water jet onto electric components.

When working above shoulder-height, use a ladder or platform that meets current regulations.

Basic maintenance jobs to be done on the machine in order to maintain efficiency and extend its service life are illustrated below.

The times and methods given in this manual are given for reference purposes only and with "normal" machine use. As a result, the intervals may be shorter when working under harsh conditions, in dusty environments or just for greater rigor.

- Before greasing, clean the grease fittings and in any case do not allow mud, dust or debris to get into the grease.
- Maintenance jobs are to be carried out with the machine stopped, disconnected from the power source with the forks on the ground.
- Maintenance jobs are to be carried out by competent qualified personnel.
- Always use tools suitable for the jobs to be done when performing maintenance.
- **Do not forget rags, tools or other material used to perform maintenance work on the machine or inside sliding parts.**

11.1.1 Maintenance chart

The intervals indicated in the chart below containing approximate values which refer to operation under normal environmental conditions. These intervals are reduced when the machine is used under particular environmental conditions (high dust concentration, extreme weather, etc..).

Every 8 hours of service

- Visually inspect the machine.

Every 50 hours of service

- Grease the sliding parts of the:
 - Masts.
 - Transfer device.
 - Carriage.
- Check wear and tear of the safety devices.
- Check wear and tear of the decals.
- Visually inspect the machine.

Every 500 hours of service

- Check the oil level in the tank (if present) and change the oil, if necessary.
- Check the oil level in the booster (if present) and change the oil, if necessary.
- Check the screws and bolts for tightness.

- Make sure the hydraulic fittings are tight.
- Check wear and tear of the pump (if present).

Every 1000 hours of service

- Visually inspect the lift chains (detached links, cracks, end links securely attached).

Every 3 months

- Have the lift chains inspected by an authorized service center.
- Write down the condition of the chains.
- Check the bearings.

11.2 HYDRAULIC SYSTEM MAINTENANCE



WARNING!

Work on the hydraulic system only after shutting down the machine and reading the entire Operation and maintenance manual.



WARNING!



Always use the required personal protective equipment.

**WARNING!****Burn hazard due to the hot hydraulic oil.**

It is strongly suggested to pay special attention to cleanliness to keep the hydraulic system and entire machine efficient.

Hydraulic system maintenance basically includes checking the levels and changing the hydraulic oil and hoses.

Change the hydraulic oil at least once every 500 hours of service. Empty the oil tank and then fill it up again.

Frequently check wear and tear of the hydraulic hoses. Replace them, if worn (or at least every 2 years).

If a hose has to be replaced, thoroughly clean inside with compressed air before installing it.

Repairs can be made only by specially trained persons.

In the event of leaks in the hydraulic system, repair immediately contacting **C.M. srl**.

When topping up the oil in the pump's tank, do not mix together oils that are not compatible and above all **do not mix mechanical oil with hydraulic oil**.

11.2.1 Checking and replacing the hydraulic oil

Read the level on the dipstick (figure below) when checking the oil level in the tank.



Dipstick

The oil level should be between the bottom and top lines: when it drops below the bottom line, add oil to the tank.

To empty the tank, remove the two screws that hold the tank in place and remove the tank, unscrew the cap and empty the tank.

Used oil must be collected. Legislation classifies used oil as hazardous waste and as such it must not be disposed in the environment. Used oil must be brought to authorized collection centers. Contact the nearest consortium for waste oil (**C.O.O.U.** - Obligatory Consortium for Waste Oil – **toll free number 800 863 048**).

Do not dispose oil or lubricating substances in the environment.



11.3 TROUBLESHOOTING CHART

PROBLEM	CAUSE	REMEDY
Too much oil used	Leak in system	Remedy leak
Forklift moves down with the load on static forks	Seals not tight	Replace them
	Distributor leaks	Replace the distributor
Forklift tilts with load on forks	Tipper seals not tight	Replace them
Forklift does not work	Oil does not flow	Engage the power take-off (version with tank and booster)
		Check couplers
		Engage control lever for tractor's distributor
Forklift does not move in steps during lifting and lowering	Safety valves faulty	Clean or replace
	Oil level too low	Top up
Control console does not work	No electrical connection	Correctly connect electric connectors
Hydraulic controls do not work or work erroneously	Hydraulic hoses not connected or incorrectly connected	Correctly connect hydraulic hoses
	Leak in hydraulic system	Remedy the leak, checking the hydraulic hoses

12 ACCESSORIES

The main accessories available for the range of C.M. forklifts are listed below:

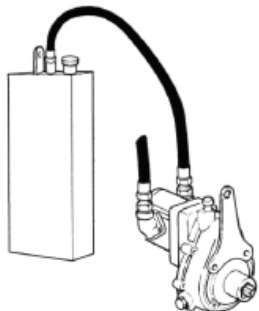

Pump assembly

It uses the tractor's outlet to run the forklift's hydraulic system.

Steel folding forks

Thanks to their reduced thickness, they are capable of engaging even the thinnest pallets.

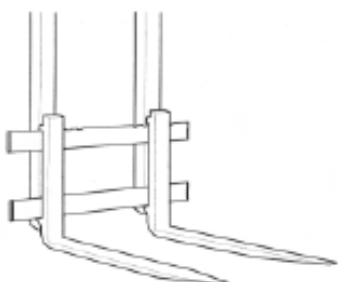

FEM forks

Similar to those used in the forklift trucks, they are capable of engaging all types of pallets as they are width-adjustable.

Load clamp

This device is used to secure the load with a movable support controlled by one or two hydraulic cylinders.

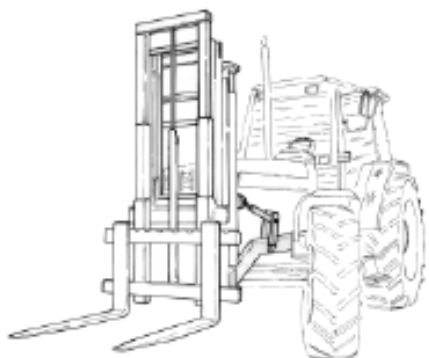
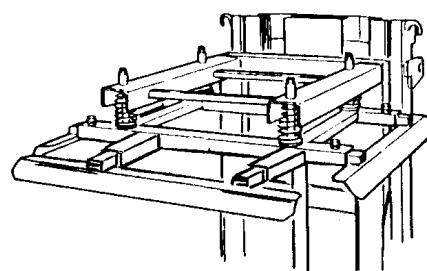

Double tipper kit

This kit allows the forklifts to be attached at the front of tractors that do not have a third hitch. The fixed brackets are not supplied by **C.M. srl.**

13 INTERCHANGEABLE EQUIPMENT

The interchangeable equipment available for C.M. forklifts is listed below:

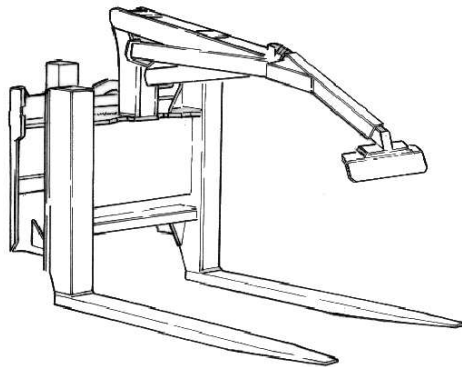

Hydraulic tippers

These devices can be attached to the forklifts to move and turn over products stored in bins.

Hydraulic buckets

These devices can be attached to the forklifts to handle and move agricultural products, cereals, sand, gravel, inert materials, liquids.

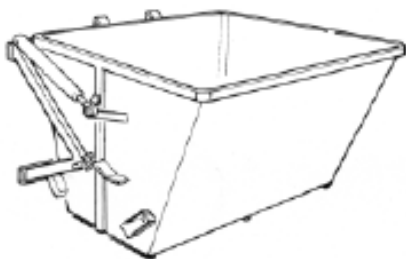
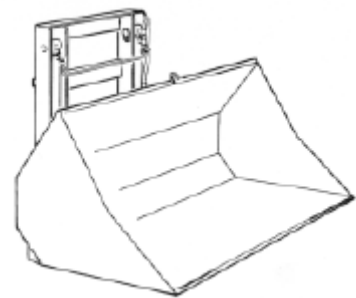

Grape container

This device can be attached to the forklifts with a special frame to handle and turn over and collect and transport agricultural products.

14 REPLACEMENT PARTS

When replacing machine parts, the customer should use only genuine spare parts ordering them directly from **C.M. srl** or authorized dealers.

When placing the order, always specify the information given on the nameplate, in particular:

- series
- model
- year of manufacture
- serial number

To identify the required replacement parts, consult the specific catalogue. When submitting the written order, indicate the component data:

- type and model
- serial number
- name of part
- quantity
- preferred means of shipment

Notwithstanding we strive to make our spare parts service as efficient, committed and focused as possible, **C.M. srl** shall not be held responsible for any delays, damage or loss of shipped material.

Shipping charges are always the recipient's responsibility.

Replacement parts are shipped cod except in special cases agreed upon with the sales offices in advance.

C.M. srl assures availability of replacement parts for at least **5 years from when production of the model ceased.**

15 WARRANTY

C.M. srl warrants that its product shall be free from defects in material and workmanship. If the product is deemed defective by C.M. during the warranty period, the company shall repair or replace the defective parts free of charge. If the repair is made at an authorized service center, labor and the replacement parts shall be provided free of charge by C.M. srl.

The machines are covered by a 12-month warranty.

The warranty does not cover any damage incurred during shipment or accidents, if the serial number has been removed canceled or altered, if the machine owner is not the original one, if the event of misuse, negligence, inadequate or poor maintenance, repairs, modifications or alterations performed by persons not duly authorized by **C.M. srl** and in any case causes that do not depend on the manufacturer and, in particular, unintended use of the machine and tampering of the safety devices. In this case, the customer shall be held responsible for the cost of labor, replacement parts and travel expenses.

Any defective parts replaced under warranty are the property of **C.M. srl**.

The manufacturer shall not be held responsible for lost time or any other expenses incurred due to lost time.

These terms and conditions cannot be modified or replaced by any other verbal agreement unless done in writing by **C.M. srl**.

