



EN

# ***Green Climber***

## ***LV600 Plus***

### **OPERATIONS AND MAINTENANCE MANUAL**



VISIT OUR WEBSITE



<https://www.mdsrl.com>

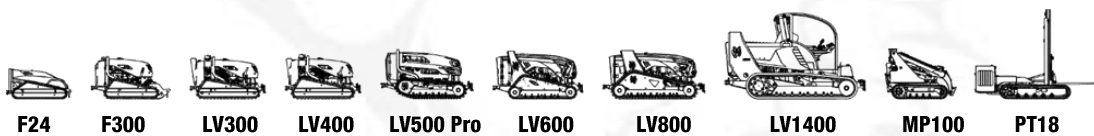

**A COMPANY WITH QUALITY MANAGEMENT SYSTEM CERTIFIED BY DNV GL ISO 9001:2015**



Manual Version Rev. 00  
of 17/12/2020



---

## TABLE OF CONTENTS

FOREWORD .....	4
<b>1. GENERAL INFORMATION .....</b>	<b>5</b>
1.1 IDENTIFICATION OF THE DOCUMENT “OPERATIONS AND MAINTENANCE MANUAL” .....	5
1.2 PURPOSE OF THE MANUAL.....	5
1.3 STORAGE .....	6
1.4 GENERAL INFORMATION .....	6
1.5 WARRANTY AND INFORMATION REGARDING RESPONSIBILITY .....	9
1.6 MANUFACTURER ID.....	11
1.7 MACHINE ID .....	12
1.8 DESCRIPTION OF THE MACHINE .....	13
1.8.1 TECHNICAL DATA	
1.8.2 WORK ENVIRONMENT .....	14
1.8.3 GENERAL DESCRIPTION OF THE MACHINE AND OPERATIONS .....	15
1.9 OPERATING CONDITIONS.....	20
1.10 WORKSTATIONS .....	21
1.11 REFERENCE STANDARDS .....	22
<b>2. OPERATING THE LV600 .....</b>	<b>24</b>
2.1 TRANSPORT .....	24
2.2 OPERATING THE MACHINE .....	25
2.2.1 HOW TO USE THE HAND LEVERS .....	45
2.2.2 EMERGENCY OPERATIONS .....	46
2.2.3 EMERGENCY INTERVENTION.....	50
DESCRIPTION OF THE CONTROL PANEL.....	52
2.2.5 REFUELLING .....	56
2.2.6 CHECKING THE LEVEL, TOPPING UP AND CHANGING HYDRAULIC OIL .....	58
2.2.7 CHECKING AND TOPPING UP COOLANT FLUID .....	59
2.2.8 CHECKING THE ENGINE OIL LEVEL AND TOPPING UP .....	61



# Operations and Maintenance



## LV600

---

2.2.9 CHECKING THE FUEL FILTER CARTRIDGE .....	64
<b>3. MAINTENANCE AND TECHNICAL ASSISTANCE .....</b>	<b>67</b>
3.1 MAINTENANCE .....	68
3.1.1 CLEANING .....	68
3.1.2 VISUAL INSPECTION.....	73
3.1.3 LUBRICATION .....	75
3.1.4 TRACK MAINTENANCE .....	77
3.2 TECHNICAL ASSISTANCE .....	80
3.2.1 RELAY AND FUSE POSITION DIAGRAM .....	85
3.2.2 PROBLEM SOLVING GUIDE .....	89
<b>ATTACHMENT A .....</b>	<b>93</b>
<b>ATTACHMENT B .....</b>	<b>94</b>
B.1 FOREWORD.....	94
B.2 APPLYING EQUIPMENT TO THE MACHINE.....	95
B.3 USING THE LV600 WITH THE TXL-D SERIES FLAIL MOWER .....	98
<b>LOG BOOK.....</b>	<b>101</b>
ROUTINE MAINTENANCE.....	101
UNSCHEDULED MAINTENANCE.....	118



# Operations and Maintenance



## LV600

---

### FOREWORD

MDB S.r.l. would like to thank you for choosing this machine. This manual contains the description of the functions and the instructions required to correctly perform the main operations of use and maintenance, both routine and occasional, of the LV600 machine.

*The instructions for use must be strictly observed to obtain the best performance, to ensure long working life of the parts and to work safely.*

Users of the **LV600** must read this manual before operating the machine. *This manual must be considered as an integral part of the machine, be kept in good condition, and handed over to any future owners together with the machine.*

Pursuant with a policy of providing increasingly safe, efficient and technologically advanced vehicles, **MDB S.r.l.** reserves the right to use qualitatively better equipment and means at any time.

Sincerely,

Legal Representative

*DiBiase Mario*



C.da Sant'Onofrio, 6/A  
66034 Lanciano (CH) – ITALY  
Tel. (+39) 0872.50221 – Fax (+39) 0872.50231  
E-mail: [info@mdb srl.com](mailto:info@mdb srl.com) – Web: [www.mdb srl.com](http://www.mdb srl.com)



## 1. GENERAL INFORMATION

### 1.1 “OPERATIONS AND MAINTENANCE MANUAL” IDENTIFICATION

The “Operation and Maintenance Manual” is a document issued by **MDB S.r.l.** and must be considered an integral part of the machine.

#### COPYRIGHT

**MDB S.r.l.** owns the copyright of this operation and maintenance manual. This manual is intended for the personnel who use the LV600 . It contains instructions and drawings of a technical nature, which must not be reproduced (even in part), nor disclosed by any means, used for competitive purposes nor made available to third parties.

**MDB S.r.l. prohibits the total or partial reproduction of this manual and the disclosure of its contents in any form.**

### 1.2 PURPOSE OF THE MANUAL

The purpose of the “Operation and maintenance manual” is to provide all personnel delegated to operate the LV600 with all the instructions necessary to operate it diligently and maintain it in optimal conditions. Obviously, particular attention has been paid to ensure that this takes place in the safest possible conditions for the operators.

The equipment is provided to be used as specified in this manual. When using the machine, operators must



# Operations and Maintenance



## LV600

---

always be aware of safety aspects, to improve its safety.



---

### PLEASE NOTE:

The machine manufacturer may not be held responsible for damage to persons, animals, property or the environment resulting from use of the equipment by operators who do not meet the necessary requirements.

---

## 1.3 STORAGE

The following instructions must be followed closely in order to keep the manual in perfect conditions:

- ☞ Use the manual in such a way that it is not damaged in any manner;
- ☞ Do not remove, add, change or write in any part of the manual; updates may be carried out only by MDB S.r.l.
- ☞ Keep the manual in an area protected against damp, so that its lifetime is not compromised;
- ☞ Hand over the manual to any other user or future owner of the machine.

## 1.4 GENERAL INFORMATION

Get to know the equipment before starting to use it by reading this manual carefully. Operators must be properly and fully trained on the contents of [CHAPTER 2](#) concerning how to operate the machine and how it works before the machine is used for the first time.



C.da Sant'Onofrio, 6/A  
66034 Lanciano (CH) – ITALY  
Tel. (+39) 0872.50221 – Fax (+39) 0872.50231  
E-mail: [info@mdbsrl.com](mailto:info@mdbsrl.com) – Web: [www.mdbsrl.com](http://www.mdbsrl.com)



## Operations and Maintenance



### LV600

---

The operation and maintenance instructions for the LV600 are two integral parts, and must be followed for its whole service life, up to when it is dismantled and scrapped.

MDB S.r.l. declines all responsibility regarding problems, breakages, damage to persons, property or animals, even if caused by non-use of the equipment or failure to comply with the procedures and instructions in this manual;

- Due to failure to comply with the normal workplace safety regulations; of operation
- Due to lack of diligence when working;
- Due to personnel's lack of expertise and improper use of the machinery;
- Due to failure to comply with accident prevention regulations while operating or carrying out maintenance on the machinery, even if not expressly mentioned in our manual;
- Due to changes, variations and/or installation of accessories not authorised by MDB S.r.l.
  
- **MDB S.r.l.** may not be held responsible for damage caused by:
  - ☞ Natural disasters;
  - ☞ Revolts and riots;
  - ☞ Lack of maintenance or incorrect maintenance;

For replacements parts, the customer must only use ORIGINAL SPARE PARTS.

To obtain optimal performance from the equipment, check it periodically, and if necessary, replace all parts that, by their nature, are subject to wear.



C.da Sant'Onofrio, 6/A  
66034 Lanciano (CH) – ITALY  
Tel. (+39) 0872.50221 – Fax (+39) 0872.50231  
E-mail: [info@mdb srl.com](mailto:info@mdb srl.com) – Web: [www.mdb srl.com](http://www.mdb srl.com)





## Operations and Maintenance



### LV600

---

Replacing a part at the right time, not only allows the machine's operation to meet expectations, but also prevents more serious damage and/or personal injuries.

Using original spare parts maintains the machine's quality over time and entitles you to the product's WARRANTY for the period for which it is provided.

To highlight the risks or hazardous operations, this manual contains safety alerts. Each alert starts with a symbol followed a warning.

The following lines describe the symbols used:



#### DANGER

This symbol indicates an imminent risk that, if not prohibited, would cause serious injury or death to the persons involved.



#### CAUTION:

This symbol indicates a potential risk to the machine's integrity that, if not prevented, could cause damage to the machine, which could indirectly cause serious injury or death to the persons involved.



#### PLEASE NOTE:

This symbol indicates conditions that are particularly important to be able to work with the machine in a simpler and safer way.



## 1.5 WARRANTY AND INFORMATION REGARDING RESPONSIBILITY

The warranty covers manufacturing defects.

The manufacturer may not be held responsible for any damage that occurs during transport.

The machine is shipped without packaging, covered with a plastic film that protects the parts subject to oxidation in the event of contact with water or moisture.

The manufacturer undertakes to take care of fastening the machine, assuming liability if the transportation is carried out with his own means.

If the transportation is performed by a carrier, all care will be taken to ensure that the machine is not damaged but, as already noted above, the manufacturer assumes no liability if it is.

For this reason, if transported by a carrier, adequate insurance coverage should be requested.

The customer is responsible for checking the state of the goods on arrival and promptly notifying the carrier and the manufacturer of any damage.

If the customer deems it appropriate, the machine may be packed in a wooden crate at an additional cost.

The accessories and documents that accompany the machine are located on board, duly protected to prevent any damage.

Items not covered by the warranty are:

- Items that are part of the machine, but that are not manufactured by MDB (such as: tracks, transmission belts, bearings, gearboxes, etc.): these are only covered by the warranty provided by their respective manufacturers.
- Items that have deteriorated due to wear.



## Operations and Maintenance



### LV600

---

Exceptions that void the warranty:

- Modifications carried out on the machine without the written approval of MDB.
- Repairs carried out by unauthorised workshops.
- Use of non-original spare parts.
- Negligence during maintenance.
- Use of the machine not compliant with what defined in this manual.
- Removal of protection devices applied to the machine. These must never be removed, must also be inspected periodically and, if damaged, reinstated to their original conditions;
- Failure to comply with the safety measures regarding the machine subject of the operations manual.

The warranty period is specified in the offer and does not exceed 12 months from the date of shipment.

#### Warranty request

A warranty request must be made in writing to MDB by the dealer, within 4 weeks from the fault, specifying: name and address of the user; type, model, serial number, date of sale, date of the fault, number of hours of operation, circumstances and alleged causes.

For the warranty to be granted, the parts must be sent to MDB for examination and, once confirmed, replacement of the part will be authorised.



C.da Sant'Onofrio, 6/A  
66034 Lanciano (CH) – ITALY  
Tel. (+39) 0872.50221 – Fax (+39) 0872.50231  
E-mail: [info@mdbsrl.com](mailto:info@mdbsrl.com) – Web: [www.mdbsrl.com](http://www.mdbsrl.com)



## Operations and Maintenance



### LV600

---

## 1.6 MANUFACTURER IDENTIFICATION

Name: **MDB S.r.l.**

Head office: **C.da Sant'Onofrio, 6/A – LANCIANO (CH) -  
ITALIA**

Phone: **+39 0872.50221**

Fax: **+39 0872.50231**

E-mail: **info@mdbsrl.com**

VAT number: **01960690699**

### 1.6.1 TECHNICAL ASSISTANCE

Technical assistance is always provided by the manufacturer. For further information, please call:

**+39 0872.50221**



C.da Sant'Onofrio, 6/A  
66034 Lanciano (CH) – ITALY  
Tel. (+39) 0872.50221 – Fax (+39) 0872.50231  
E-mail: [info@mdbsrl.com](mailto:info@mdbsrl.com) – Web: [www.mdbsrl.com](http://www.mdbsrl.com)



## LV600

### 1.7 MACHINE IDENTIFICATION

The LV600 is identified by the CE mark, drawn in accordance with the specifications given in the 2006/42/EC European Directive, in Italian Legislative Decree No. 17/2010, which implements the Machine Directive, and in the Legislative Decree 81/08 and subsequent amendments and additions.

The essential data regarding the marking can be found on the ID plate positioned in the lower part of the same machine (see Fig. a) and is positioned as indicated in the photo on page 16, (n. 19).

			
C.da S. Onofrio, 6/A - 66034 Lanciano (CH) ITALY Tel. (+39) 0872 50221 - 508566 - Fax (+39) 0872 50231			
<input type="radio"/>	<b>Designazione:</b> <input type="text"/>	<input type="radio"/>	
<b>Modello:</b>	<input type="text"/>	<b>Anno:</b>	<input type="text"/>
<b>Potenza:</b>	<input type="text"/>	<b>Matricola:</b>	<input type="text"/>
<b>Portata:</b>	<input type="text"/>	<b>Peso:</b>	<input type="text"/>
Conforme alle Direttive comunitarie CEE/2006/42/CE e successive implementazioni In conformity with ECC rules 2006/42/CE and subsequent implementation			

Fig. a: CE Identification Label



## LV600

### 1.8 DESCRIPTION OF THE MACHINE

#### 1.8.1 TECHNICAL DATA

##### DESCRIPTION

Machine height	1100 mm
Min. machine width	1360 mm
Max. machine width	1760 mm
Machine length	2160 mm
Machine weight	1292 kg
Maximum working slope with open tracks	56°
Engine type and model	LOMBARDINI KOHLER KDI1903TCR/26B
Rated engine power	42 kW
Engine fuel	diesel
Diesel tank capacity	38 Lt
Max speed	9 Km/h
Capacity of hydraulic oil tank	32 Lt
Type and mode of radio remote control	IMET M880-THOR B2

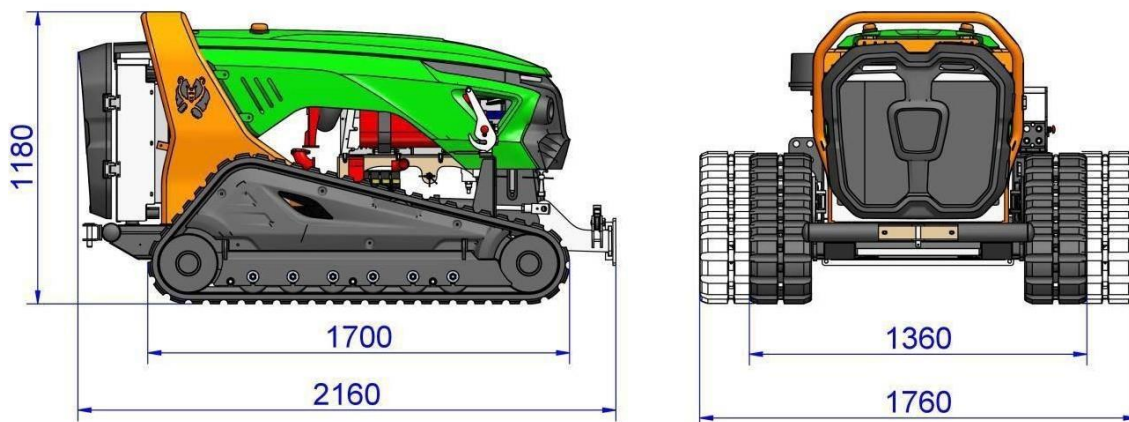



# Operations and Maintenance



## LV600

---

### 1.8.2 WORK ENVIRONMENT

#### LIGHTNING

The machine has two lighting devices at the front to improve the machine's visibility in the work area and not to light the work area at night. The machine must only be used during the day, with sufficient visibility for the operator to see the work area for a radius of at least 100 m.

#### VIBRATIONS

The machine generates vibration during use. Since it is operated from a distance by means of a radio remote control, these vibrations cannot harm the operator. For emergencies, the machine is equipped with hydraulic levers located on the left side. Their use is only permitted in an emergency, so the vibrations to the hand - arm system are negligible.

#### NOISE

The machine is intended only for outside use. Noise measurements have been made at the control position, as prescribed by the machine directive (dynamic measurement at 1m from the machine in motion, measurement time 30" for a distance of 5.6 m), with the operator at the left of the machine. The measured sound pressure level was 87 dB(A) with an uncertainty of  $K_{pA} \pm 2.8$ .

#### DEMOLISHING THE MACHINE

According to normal disposal of the machinery (after dismantling) and delivery of each component to a company specialised in the transport, disposal and/or recovery of waste.



C.da Sant'Onofrio, 6/A  
66034 Lanciano (CH) – ITALY  
Tel. (+39) 0872.50221 – Fax (+39) 0872.50231  
E-mail: [info@mdbsrl.com](mailto:info@mdbsrl.com) – Web: [www.mdbsrl.com](http://www.mdbsrl.com)



## Operations and Maintenance



# LV600

---

### 1.8.3 GENERAL DESCRIPTION OF THE MACHINE AND ITS OPERATION

The LV600 is made up of:

1. S355 and S700 steel base frame. Welded structure;
2. Tracks;
3. Hydraulic oil reservoir;
4. Diesel tank;
5. Bonnet;
6. Roll-bar;
7. Rear cover panel;
8. Air filter;
9. Exhaust assembly;
10. Engine;
11. Battery;
12. Radio remote control receiver;
13. Quick coupling for equipment;
14. Headlights;
15. Flashing lights;
16. Spare battery and battery charger for the radio remote control;
17. Vortex filter;
18. Towing hook;
19. CE plate.



C.da Sant'Onofrio, 6/A  
66034 Lanciano (CH) – ITALY  
Tel. (+39) 0872.50221 – Fax (+39) 0872.50231  
E-mail: [info@mdbsrl.com](mailto:info@mdbsrl.com) – Web: [www.mdbsrl.com](http://www.mdbsrl.com)





# Operations and Maintenance



## LV600

LV600

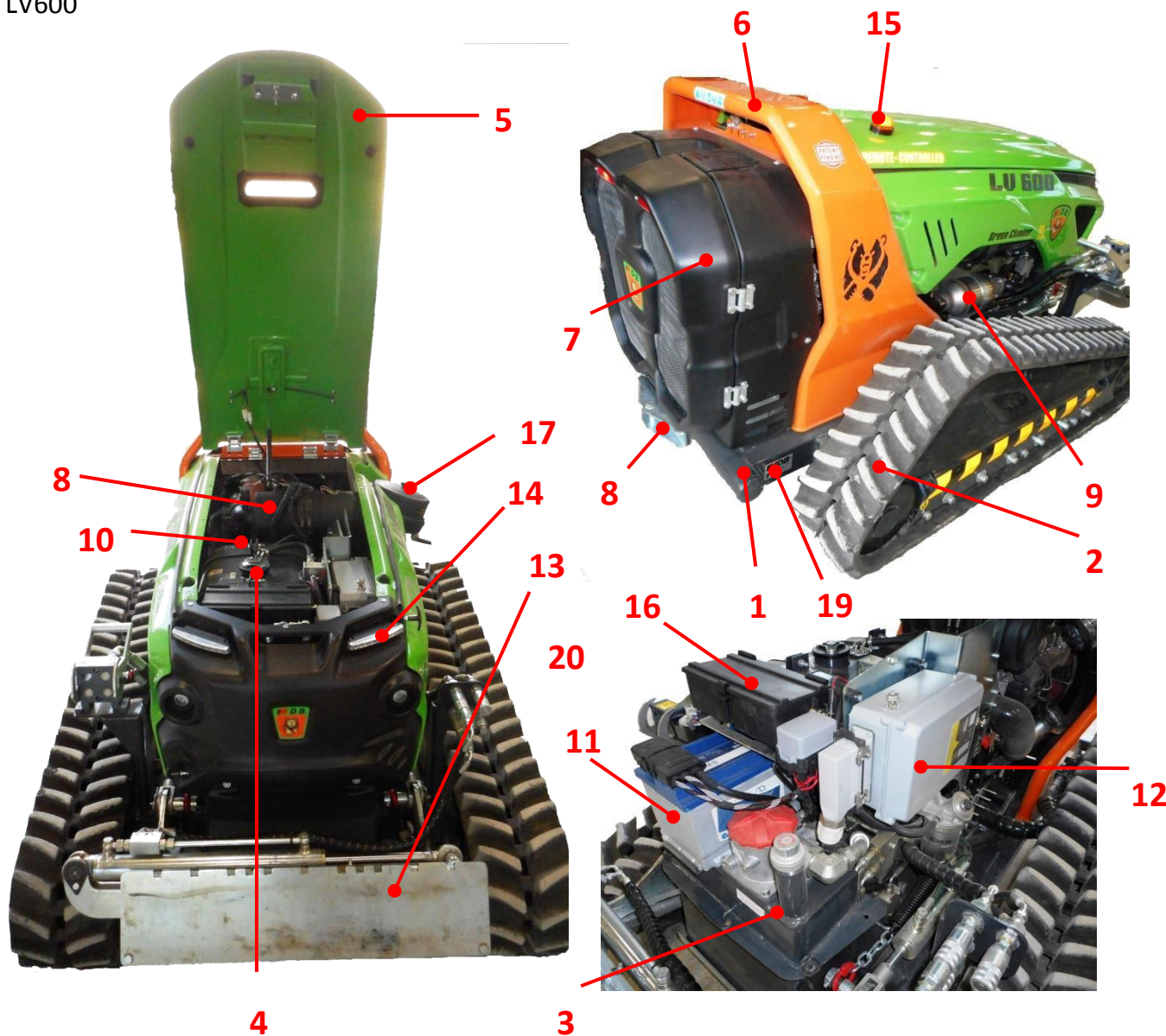

The LV600 is made up of components fixed to a welded steel frame. It is moved by rubber tracks. The vehicle's gauge is variable and configurable by means of the radio remote control system. The diesel engine drives the machine's hydraulic circuit by means of hydraulic pumps.

The LV600 is a self-propelled machine designed to be used in agriculture and forestry. The front area is equipped with quick coupling for



C.da Sant'Onofrio, 6/A  
66034 Lanciano (CH) – ITALY  
Tel. (+39) 0872.50221 – Fax (+39) 0872.50231  
E-mail: [info@mdb srl.com](mailto:info@mdb srl.com) – Web: [www.mdb srl.com](http://www.mdb srl.com)



## Operations and Maintenance



### LV600

hooking only equipment designed and manufactured by MDB. The equipment authorised by MDB to be used with the LV600 is:

Trincia serie  
UTD-130



Trincia serie  
UT-125



Trinciatrice forestale  
serie TF 130



& GD 6DQW ·2QRIULR \$  
66034 Lanciano (CH) – ITALY  
Tel. (+39) 0872.50221 – Fax (+39) 0872.50231  
E-mail: [info@mdbsrl.com](mailto:info@mdbsrl.com) – Web: [www.mdbsrl.com](http://www.mdbsrl.com)



## Operations and Maintenance



### LV600

Tiller CS-135



Sprayer BV300



Stump grinder FTR400





## Operations and Maintenance



### LV600

Snow blower DS-14



Finishing mower SRM-215



Trencher MT-1200





## Operations and Maintenance



### LV600

Thanks to its extremely low centre of gravity, the LV600 machine can easily work on any type of terrain. The machine has been tested by simulating a transverse slope of more than 56° with the maximum width configuration (fully extended undercarriage)



Its remote control allows the operator to work with in maximum safety, even on the most awkward and impassable terrain.

#### 1.8.4 OPERATING CONDITIONS

The LV600 has been built in compliance with the applicable safety-at-work regulations, directives and European standards. Only the equipment indicated in point 1.8 of this manual can be connected to it. Before applying equipment other than that indicated in point 1.8, the customer must request authorisation from MDB's technical department, that will perform the necessary checks and reply, confirming the application or otherwise. If any equipment not intended by MDB for use with the LV600 is applied to it, without first requesting authorisation and receiving a formal reply, MDB is exempted from any constructional or functional liability for the machine. Before starting work, inspect the work area and check that there are no people and/or animals present, in which case accompany them to a safe area. Mark out the work area to prevent access by unauthorised persons.



C.da Sant'Onofrio, 6/A  
66034 Lanciano (CH) – ITALY  
Tel. (+39) 0872.50221 – Fax (+39) 0872.50231  
E-mail: [info@mdb srl.com](mailto:info@mdb srl.com) – Web: [www.mdb srl.com](http://www.mdb srl.com)



## LV600

---

### 1.9 WORKSTATIONS

The operator in charge of operating the LV600 machine must be trained and informed by the MDB retailer/dealer before use. The end user is responsible for the application of the laws of the country of origin for the proper use of the equipment. While the machine is in use, other persons may not stand and/or work near the machine nor enter the marked-out area. The operator controls the machine via a remote control and is therefore not near the danger area. He must, however, bear in mind that he must remain at a distance of at least 3 metres behind the machine, never in front of it. The maximum operating range of the radio remote control is set to 100 m. The operator using this machine must have psycho-physical ability certified by a competent physician.



**Danger!** Safety alerts of the machine are both visual and acoustic. It is forbidden to allow persons who do not have a good level of vision and hearing to use the machine.



### 1.10 REFERENCE STANDARDS

#### 1.8.1 ITALIAN LEGAL REGULATIONS

- ☞ LEGISLATIVE DECREE no. 81/2008 and subsequent amendments and additions;
- ☞ LEGISLATIVE DECREE no. 17/2010;
- ☞ LEGISLATIVE DECREE no. 262/2002;
- ☞ LEGISLATIVE DECREE no. 80/2016;
- ☞ LEGISLATIVE DECREE no. 86/2016

#### 1.8.2 EUROPEAN STANDARDS

- ☞ MACHINERY DIRECTIVE 2006/42/EC;
- ☞ ELECTROMAGNETIC COMPATIBILITY DIRECTIVE 2014/30/EU;
- ☞ LOW VOLTAGE DIRECTIVE 2014/35/EU;
- ☞ DIRECTIVES FOR THE IMPROVEMENT OF THE SAFETY AND HEALTH OF WORKERS AT WORK 80/1107/CEE, 82/605/CEE, 83/477/CEE, 86/188/CEE, 88/642/CEE, 89/391/CEE, 89/654/CEE, 89/655/CEE, 89/656/CEE, 90/269/CEE, 90/270/CEE, 90/394/CEE, 90/679/CEE, 93/88/CEE, 95/63/CE, 97/42/CE, 98/24/CE, 99/38/CE, 99/92/CE, 2001/45/CE, 2003/10/CE, 2003/18/CE, 2004/40/CE, 92/58/CEE, 2002/44/CE, 2006/25/CE, as applicable;
- ☞ ENVIRONMENTAL ACOUSTIC EMISSION DIRECTIVE FOR MACHINES AND EQUIPMENT INTENDED TO OPERATE OUTDOORS 2000/14/CE and 2005/88/CE.



# Operations and Maintenance



## LV600

---

### 1.8.3 TECHNICAL HARMONISED STANDARDS

- ☞ EN ISO 12100:2010 - Safety of Machinery – General Principles for Design – Risk Assessment and Risk Reduction;
- ☞ EN ISO 4254-1:2015 - Agricultural machinery – Safety – Part 1: General Requirements;
- ☞ EN ISO 60204-1:2006 + AC:2010 - Safety of Machinery – Electrical Equipment of Machines – Part 1: General Requirements;
- ☞ EN ISO 16231-1:2013 - Self-propelled agricultural machinery – Assessment of stability – Part 1: Principles;
- ☞ EN ISO 16231-2:2015 - Self-propelled agricultural machinery – Assessment of stability – Part 2: Determination of static stability and test procedures;
- ☞ EN 349:1993+A1:2008 - Safety of machinery – Minimum gaps to avoid crushing of parts of the human body;
- ☞ EN ISO 13857:2008 Safety of machinery - Safety distances to prevent hazard zones being reached by upper and lower limbs
- ☞ EN ISO 4254-7:2010 - Agricultural Machinery – Safety – Part 7: Combine harvesters, forage harvesters and cotton harvesters;
- ☞ EN ISO 4254-12:2012 - Agricultural machinery – Safety – Part 12: Rotary disc and drum mowers and flail mowers;
- ☞ EN ISO 3744:1995 - Acoustics - Determination of sound power levels of noise sources using sound pressure;
- ☞ ISO 6395:1988 - Acoustics - Measurement of exterior noise emitted by earth-moving machinery - Dynamic test conditions.





## LV600

## 2. HOW TO USE THE LV600 MACHINE

### 2.1 TRANSPORT

The LV600 is delivered to the buyer adequately protected against impact during transportation. On arrival at the destination, use the machine's lifting points, located in the areas identified in the photos, to place it on the ground.





## LV600

### 2.2 USING THE MACHINE

The LV600 has a unique radio remote control system. To operate the machine, you must start its heat engine. First make sure that the red battery isolator lever (Fig. 1) has been turned clockwise 

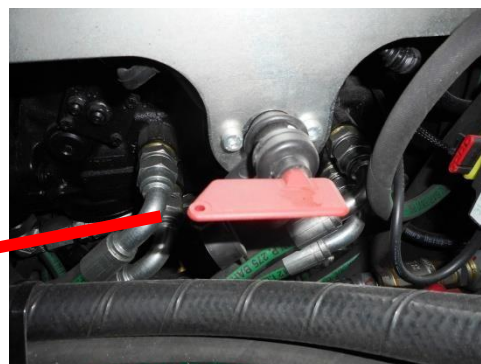

Fig. 1

Then use the control panel at rear left of the machine as shown in figure 2.



Fig. 2



## Operations and Maintenance



### LV600

---

#### CONTROL PANEL



Use the key-operated selector switch to turn on the engine, by performing the following operations:



Key inserted in the zero position.



Turn the key clockwise to the 1st click in position (1).

The engine of the LV600 machine can be powered up in two different ways:

- A. Turning the key to the “start” position as follows;
- B. By using the remote control.



## Operations and Maintenance



### LV600

---

#### POWERING UP THE ENGINE USING THE KEY FROM THE CONTROL PANEL



Turn the key clockwise, until it clicks for the 2nd time and bring it to START position, releasing it when the engine has started (the key will return to position 1 automatically).

The engine is now running, accelerate until it reaches 2000 rpm so that it can effectively transfer power to the machine's hydraulic system. Make sure that all the control warning lights are off when the engine is running.

If the engine fails to start, refer to the dedicated section in this manual (PARAGRAPH 3.2.2 PROBLEM SOLVING) to solve the problem.



**Caution!**  
If the machine does not start up, wait a few seconds before repeating the ignition procedure.



**Caution!**  
NEVER keep the key in START position for more than 15 seconds or the engine will overheat.



**Caution!**  
NEVER operate the starter motor when the engine is running, as this could damage the starter motor pinion and/or the spur gear.

Keep the engine running idle for at least 15 seconds before starting work.



## Operations and Maintenance



### LV600



**Caution!**

At first start-up, allow the engine to run idle for at least 15 minutes, while checking that the engine oil pressure is correct, that there are no diesel fuel or coolant fluid leaks and that the warning lights and/or indicators work correctly.



**Caution!**

Vary the speed and load of the engine during the first hour of operation. Short periods of maximum engine speed and load are recommended. Avoid prolonged operations with minimum and maximum speeds and loads during the next four to five hours.

Work can now be started using the remote control (fig. 6) after having connected the transmitter to the radio receiver.

Make sure that all the control warning lights are off when the engine is running.

If the engine fails to start, refer to the dedicated section in this manual (PARAGRAPH 3.2.2 PROBLEM SOLVING) to solve the problem.

### CONNECTING THE TRANSMITTER TO THE RADIO RECEIVER

Turn on the radio transmitter, with the transmitter unit off:

- ☞ Insert a charged battery into the transmitter.
- ☞ Check that the STOP mushroom-shaped button is not activated and there are no other active commands.

Wait 2 seconds until the "RX" radio receiver runs the safety tests. If the test result is positive, the red "STOP A" and "STOP B" LEDs, and the green POWER LED (on the receiver itself) will remain on.



# Operations and Maintenance



## LV600



Fig. 3

Turn on the transmitter via the START button in fig. 4, waiting for the connection between the transmitter “TX” and the receiver “RX” to establish (to check if the connection was successful, check that the GREEN and the BLUE LEDs on the TX are flashing [Fig. 4] and that the RF LED Busy WHITE is lit on the RX [Fig. 3]) .



Fig. 4



C.da Sant'Onofrio, 6/A  
 66034 Lanciano (CH) – ITALY  
 Tel. (+39) 0872.50221 – Fax (+39) 0872.50231  
 E-mail: [info@mdb srl.com](mailto:info@mdb srl.com) – Web: [www.mdb srl.com](http://www.mdb srl.com)



## Operations and Maintenance



### LV600

---

#### B. and D. IGNITION WITH RADIO TRANSMITTER

The machine engine can now be started by pressing button “A” in fig. 5.



Fig.5



It is forbidden to turn on the transmitter in places that do not allow full visibility of the machine operated by remote control. Activating the transmitter indoors or away from the receiver, does not allow to have real awareness of the manoeuvres that are being carried out, resulting in a situation of danger.

When the engine is running; accelerate until it reaches 2000 rpm so that it can effectively transfer power to the machine's hydraulic system. Make sure that all the control warning lights are off when the engine is running.



## Operations and Maintenance



### LV600

If the engine fails to start, refer to the dedicated section in this manual (PARAGRAPH 3.2.2 PROBLEM SOLVING) to solve the problem. Keep the engine running at idle speed for a variable time that depends on outside temperature, see the table below:

Environmental temperature	TIME
$\leq -20^{\circ}\text{C}$	2 minutes
from $-20^{\circ}\text{C}$ to $-10^{\circ}\text{C}$	1 minute
from $-10^{\circ}\text{C}$ to $-5^{\circ}\text{C}$	30 seconds
from $-5^{\circ}\text{C}$ to $5^{\circ}\text{C}$	20 seconds
$\geq 5^{\circ}\text{C}$	15 seconds

Start operating with the radio control (fig. 6).



Fig. 6





# Operations and Maintenance



## LV600

### RADIO REMOTE CONTROL LED INDICATORS

The radio remote control is equipped with LEDs that signal the following to the user:

- The operating status
- Malfunctions
- Type of fault

TRANSMITTER	
	The receiver is equipped with 3 LEDs informing the operator: The operating status Malfunctions Type of failure and diagnostic functions Low battery
STATUS OF THE LED TX (GREEN)	INDICATION
Off	The transmitter is off or is faulty (see chap. 3.2.2)
On	The transmitter is operating
Flashing	The transmitter is turned on but is not operational
STATUS OF THE LED (YELLOW)	INDICATION
Two flashes every 20s.	Low battery
Morse Code	Indication of transmitter error
RX LED STATUS (BLUE)	INDICATION
Off	The receiver is off or faulty
Flashing	Radio connection with receiver established
On	The receiver is operational





# Operations and Maintenance



## LV600

### BATTERY CHARGE STATUS

The battery charge status is indicated by the YELLOW LED.  
YELLOW LED off means that the battery is charged  
If the YELLOW LED is flashing regularly, it indicates that the battery is low, and the transmitter must be switched off to replace the battery with a charged one. A low battery will last for about 10-15 min.



### JOYSTICK FUNCTIONS - LEFT-HAND SIDE - X-

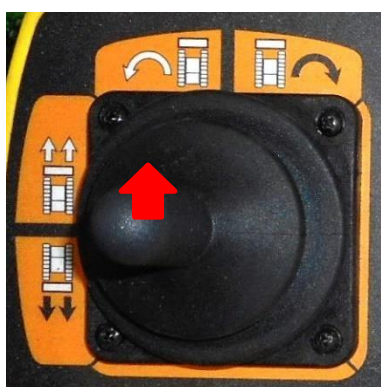

FORWARD

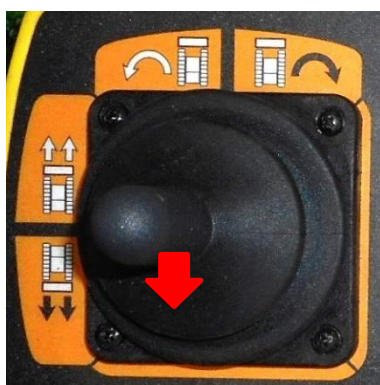

REVERSE





# Operations and Maintenance



## LV600



DRIVE FORWARD, TURN RIGHT

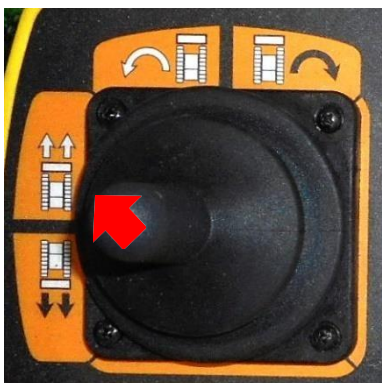

DRIVE FORWARD, TURN LEFT



REVERSE, TURN LEFT





# Operations and Maintenance



## LV600



REVERSE, TURN RIGHT



COUNTER ROTATION TO THE RIGHT



COUNTER ROTATION TO THE LEFT





# Operations and Maintenance



## LV600

### RIGHT-HAND SIDE JOYSTICK FUNCTIONS - Y-



LIFTING OF ATTACHMENT PLATE



LOWERING OF ATTACHMENT PLATE



LEFT SIDE SHIFTING OF ATTACHMENT PLATE





# Operations and Maintenance



## LV600



### RIGHT SIDE SHIFTING OF ATTACHMENT PLATE



### CENTRAL CONTROL FUNCTIONS

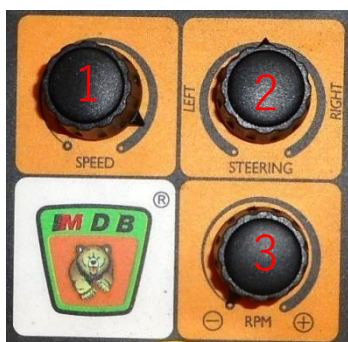

- 1 ADJUSTING SPEED
- 2 SET MACHINE DIRECTION
- 3 INCREASE ENGINE RPM

#### 1 - ADJUSTING THE SPEED

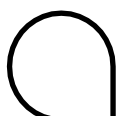

TURN CLOCKWISE: MAXIMUM SPEED

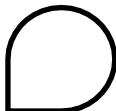

TURN ANTICLOCKWISE: MINIMUM SPEED

#### 2 - SET MACHINE DIRECTION

The direction function allows the machine to advance straight or more or less towards left or right, depending on how far knob n. 2 is turned clockwise or anticlockwise. This function is necessary to steer the machine towards the desired direction, without being influenced by the uneven ground, when it is running on steep terrain.



C.da Sant'Onofrio, 6/A  
 66034 Lanciano (CH) – ITALY  
 Tel. (+39) 0872.50221 – Fax (+39) 0872.50231  
 E-mail: [info@mdbsrl.com](mailto:info@mdbsrl.com) – Web: [www.mdbsrl.com](http://www.mdbsrl.com)



# Operations and Maintenance



## LV600

TURN  
ANTICLOCKWISE

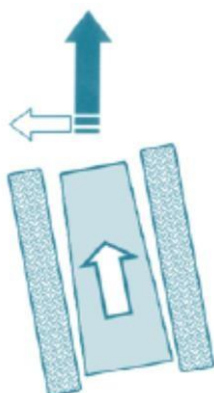
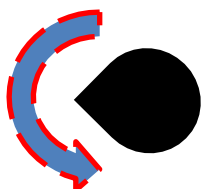

LEFT DIRECTION

TURN THE  $\pm$  KNOB ANTICLOCKWISE TO STEER THE MACHINE STRAIGHT WITH A DIRECTION TOWARDS THE LEFT

POSITION  
"0"

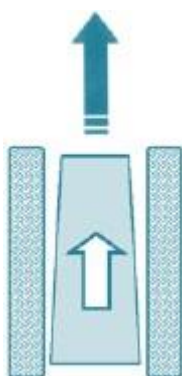

"0" POSITION

THE MACHINE WILL GO STRAIGHT WITHOUT FOLLOWING ANY DIRECTION

TURN  
CLOCKWISE

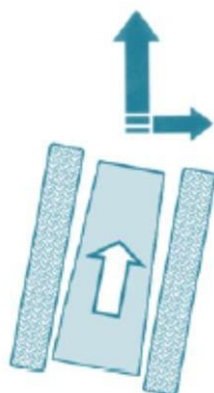
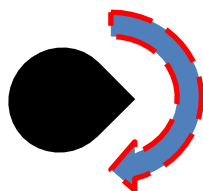

RIGHT DIRECTION

TURN THE KNOB  $\pm$  CLOCKWISE TO STEER THE MACHINE STRAIGHT WITH A TRAJECTORY TOWARDS THE RIGHT





## Operations and Maintenance



### LV600

#### 3 - ENGINE RPM

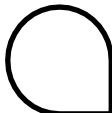

TURN CLOCKWISE: MAX. ENGINE SPEED

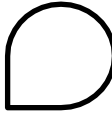

TURN ANTICLOCKWISE: MIN ENGINE SPEED

#### LOWER CONTROL FUNCTIONS



EQUIPMENT ON/OFF: ON SWITCHED ON - OFF SWITCHED OFF.

1 Hold the switch in the ON position for at least 3 seconds to turn on the equipment.

Blue led on indicates that the equipment is on.



2 REVERSES EQUIPMENT ROTATION

3 REVERSES THE DIRECTION OF THE MACHINE

4 INCREASES/REDUCES THE MACHINE'S GAUGE

5 EMERGENCY BUTTON

6 FLOATING PLATE MODE ACTIVATION

7 HEADLIGHTS ON/OFF: ON SWITCHED ON - OFF SWITCHED OFF

8 AUXILIARY HYDRAULIC CONTROL OF THE EQUIPMENT (see reference chapter on equipment for information about its use)

9 START FAN FOR CLEANING THE RADIATOR



C.da Sant'Onofrio, 6/A  
66034 Lanciano (CH) - ITALY  
Tel. (+39) 0872.50221 - Fax (+39) 0872.50231  
E-mail: [info@mdbsrl.com](mailto:info@mdbsrl.com) - Web: [www.mdbsrl.com](http://www.mdbsrl.com)



# Operations and Maintenance



## LV600



**Danger!**  
If equipment is installed on the machine, do not operate it from the front, always stay behind it.



**Caution!**  
With equipment installed on the machine, there is a hazard to the operator's body and face from blunt objects being projected from the front area of the machine. Always wear the PPE indicated in this manual and on the labels on the machine. Always use as intended and follow safe practices, remaining behind the machine and NEVER in front of it. Do not fail to comply with this obligation for any



reason.



**Danger!**  
Never stand or manoeuvre the machine from a position in the area below it on steep terrain, as the machine could overturn in this area. Always stand or manoeuvre the machine from the area above it.





# Operations and Maintenance



## LV600



### **Caution!**

The radio signal between the transmitter and the receiver has been set for a maximum operating radius of 100 metres. If this distance is exceeded, the signal could be lost, which would block the machine and turn off the engine. To restore normal operation, follow the instructions in paragraph 2.2.1 of this manual.

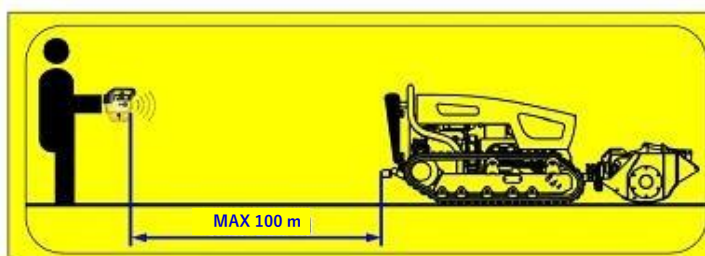

### **Danger!**

Make sure that there are no persons and/or animals in the work area before starting work and manoeuvring the machine. Mark out the work area so that people and/or animals cannot enter. Failure to comply with this safety procedure could cause risk of serious injury and/or death to persons or animals.

### OPERATING THE MACHINE CORRECTLY



While driving, never steer from flat terrain onto uphill terrain. If it is absolutely necessary to do so, steer gradually, taking great care.



## Operations and Maintenance



### LV600

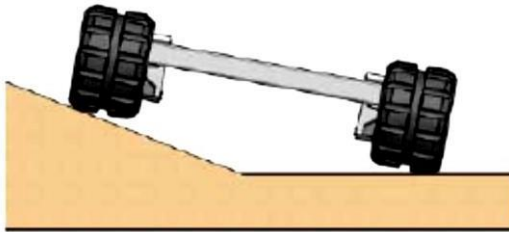

Avoid moving along the edge of sloping terrain or in rough terrain with one track on horizontal ground and the other on a slope. Always drive with the slides resting on the same level to avoid damaging the tracks.

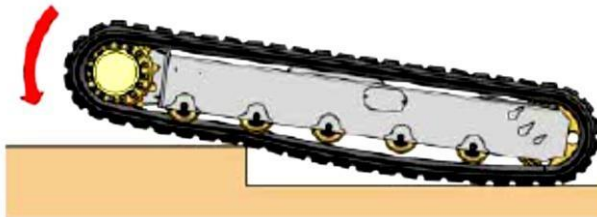

When the machine moves as shown in the figure, a space is created between the supporting rollers and the track, with the risk that the track comes out of its housing.

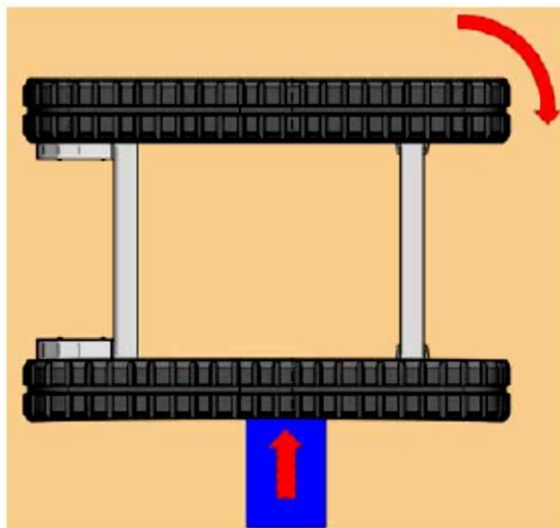

When changing direction in a situation in which the track cannot move sideways because of an obstacle, the track could be damaged and come out of its seat.

#### STOPPING THE MACHINE

The machine engine can be stopped in two ways:

- Manually;
- With the remote control.

To turn off the engine manually, turn the key switch on the control panel shown in Fig.2 on page 26 to the "0" position.

To turn off the engine in "RADIO" mode, press button "B" shown in Fig. 5.



C.da Sant'Onofrio, 6/A  
66034 Lanciano (CH) – ITALY  
Tel. (+39) 0872.50221 – Fax (+39) 0872.50231  
E-mail: [info@mdb srl.com](mailto:info@mdb srl.com) – Web: [www.mdb srl.com](http://www.mdb srl.com)



# Operations and Maintenance



## LV600



### Caution!

Unless you are in an emergency situation, always remember not to turn off the engine suddenly, especially when it is running at high rpm or the machine is moving fast. Before turning off the engine, let it run idle for a short time and always deactivate any equipment using lever 1 on the LOWER CONTROL FUNCTIONS (page 31), until the blue LED goes off. Turning off the machine's engine before deactivating the equipment could damage the hydraulic system.

At the end of the work session, always turn the battery isolator shown in Fig. 1 anticlockwise  to open the safety circuit.



### Danger!

Do not use the emergency button to turn off the machine, unless there is an emergency situation. Continuous use of this button to stop the engine in normal circumstances could damage the hydraulic system.



### Danger!

Never tamper with the machine's safety systems, nor remove its fixed or mobile guards.



### Caution!

Before starting the machine at the beginning of the work shift, always check that all the safety systems are in working condition, the fluid levels are correct and the tension of the tracks correspond to the parameters given in the maintenance chapter.



# Operations and Maintenance



## LV600

### 2.2.1 HOW TO USE THE MANUAL LEVERS

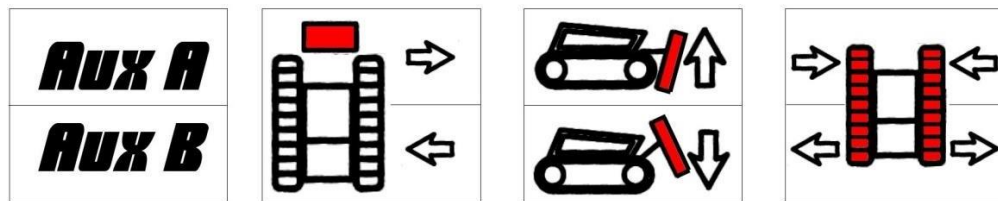
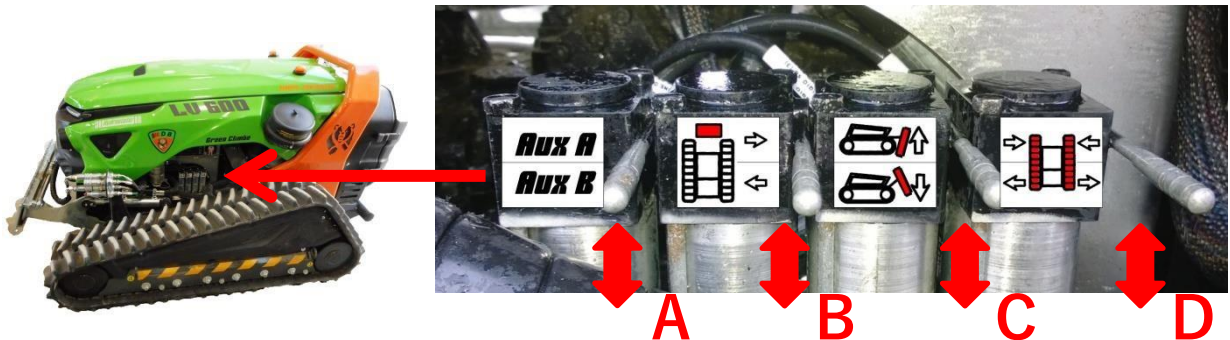



Fig. 7

The four manual levers are positioned under the control panel, on the left side of the machine (fig. 7).

As indicated by pictograms in these places, the levers have the following operations:

**A**  AUXILIARY COMMAND (varies for each equipment. Consult the attachments to this manual, to find out to which equipment the control has been coupled)

**B**  SHIFT FRONT PLATE TO RIGHT/LEFT

**C**  RAISE/LOWER FRONT PLATE

**D**  INCREASE / REDUCE MACHINE TRACK



C.da Sant'Onofrio, 6/A  
 66034 Lanciano (CH) – ITALY  
 Tel. (+39) 0872.50221 – Fax (+39) 0872.50231  
 E-mail: [info@mdb srl.com](mailto:info@mdb srl.com) – Web: [www.mdb srl.com](http://www.mdb srl.com)



## LV600

### 2.2.2 EMERGENCY OPERATION

In the event of a radio remote control failure, repair the machine on site. If this is not possible, inform the breakdown services so that lifting equipment can be used to take the machine to the nearest authorised workshop.

If the radio battery is flat, replace the battery with the spare one in the special container shown on page 16 of this manual and in fig. 8.



Fig. 8

The machine can also be operated by connecting the transmitter of the radio control directly to the control panel of the radio receiver with the cable supplied.



# Operations and Maintenance



## LV600

### HOW TO CONNECT THE CABLE FROM THE TRANSMITTER TO THE RADIO RECEIVER

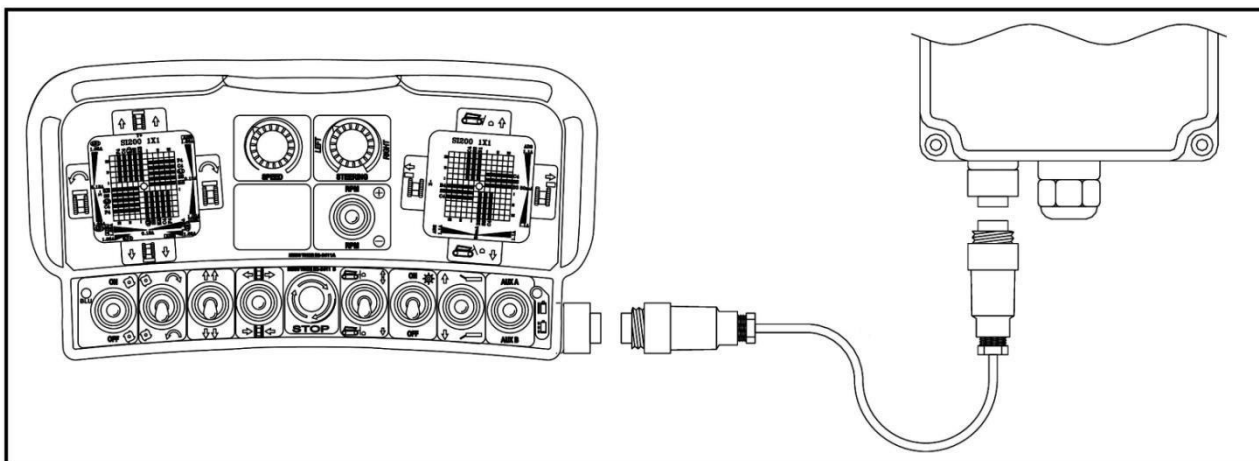

Take the wiring cable shown in the figure.

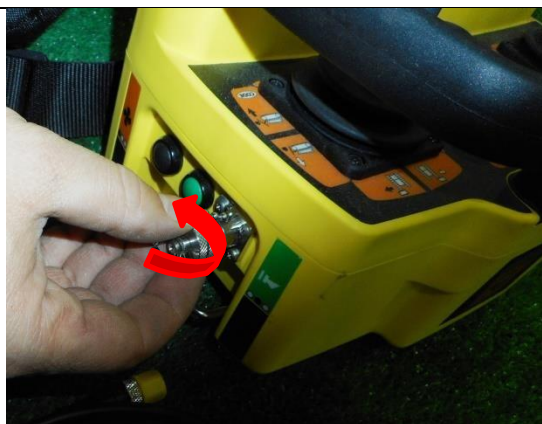

Turn the metal knob shown in the diagram above the receiver of the remote control counterclockwise, until it is completely disconnected.





## Operations and Maintenance



### LV600



Remove the yellow rubber coating at the end of the wiring cable by turning it counterclockwise.



Take the end of the cable with 4 male connectors shown in the figure.



Insert the end of the cable, making sure to match the 4 male connectors with the 4 female sockets of the connector located on the transmitter of the radio control.

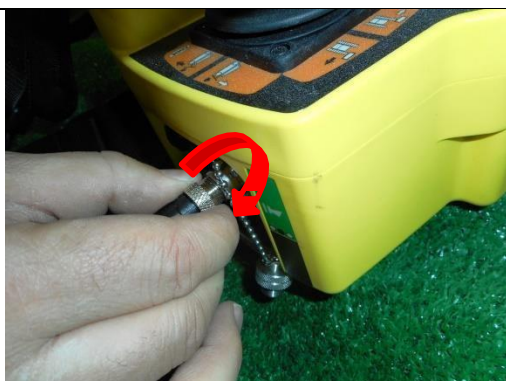

Turn clockwise to tighten the contact.



## Operations and Maintenance



### LV600



Open the first hood of the machine using the lever shown in the figure.

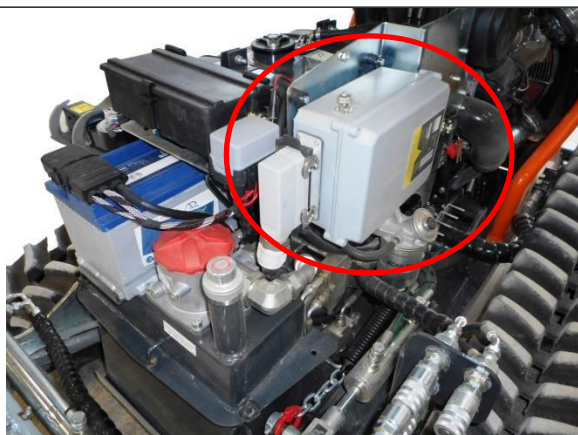

Locate the radio receiver.



Turn the metal knob shown in the diagram above the receiver of the remote control counterclockwise, until it is completely disconnected.



Take the end of the cable with 4 male connectors shown in the figure.



## Operations and Maintenance



### LV600



Insert the end of the cable, making sure to match the 4 male connectors with the 4 female sockets of the connector located on the receiver of the radio control.

### 2.2.3 EMERGENCY INTERVENTION

If, while using the machine, the operator needs to block the machine and is unable to do so using the normal radio remote control and/or control panel, the machine is equipped with 2 emergency buttons. One is on the left side of the machine, on the control panel, and the other is on the radio remote control. These are easily identifiable red mushroom-shaped buttons (Fig. 9).

Fig. 9





## Operations and Maintenance



### LV600



When the emergency button is pressed, it remains down, and the machine's engine is immediately turned off, blocking any movement. To start the machine again once safe working conditions have been restored:

- Turn the red emergency button clockwise (fig. 10)



Fig. 10

- The button is now released. To start the engine and continue working, follow the instructions in paragraph 2.2 of this manual.



## Operations and Maintenance



### LV600

#### 2.2.4.1 DESCRIPTION OF THE CONTROL PANEL

The control panel is located on the left side of the machine.



Upon system start-up, the machine displays the welcome page for a short time



The main work page appears after a few seconds. This page contains all information regarding the engine.



# Operations and Maintenance



## LV600



Angle page

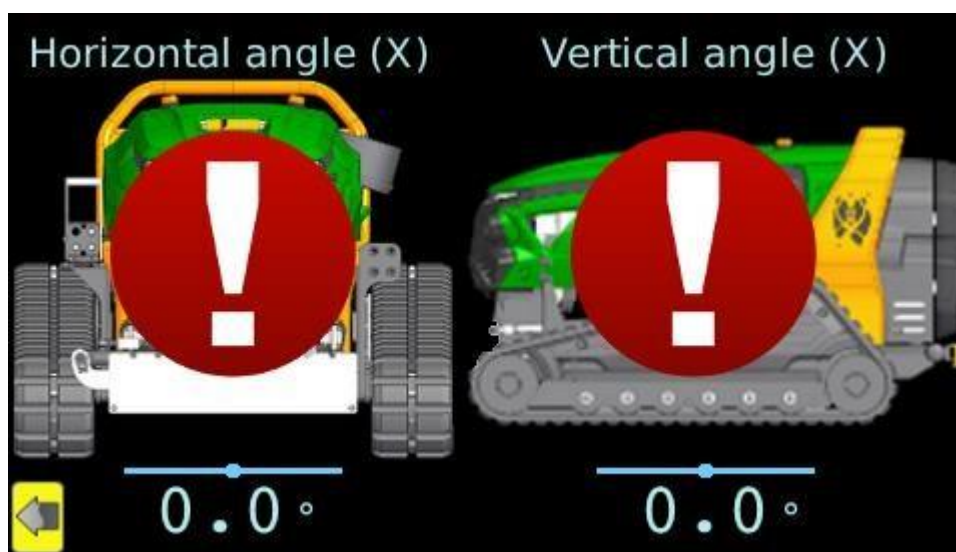

This page will be displayed using the **W** key. The angle of the machine can be monitored both horizontally and vertically; once it reaches a horizontal and/or vertical angle of 36 degrees, the alarm signal will appear over the image. To exit the page, use the **Q** key at bottom left.



### **Danger!**

**NEVER** exceed 36° horizontal and/or vertical inclination with closed tracks and **NEVER** exceed 42° with the tracks open. The machine could overturn and cause serious harm to people or objects!



C.da Sant'Onofrio, 6/A  
66034 Lanciano (CH) – ITALY  
Tel. (+39) 0872.50221 – Fax (+39) 0872.50231  
E-mail: [info@mdbsrl.com](mailto:info@mdbsrl.com) – Web: [www.mdbsrl.com](http://www.mdbsrl.com)



# Operations and Maintenance



## LV600

### Alarm page

This page will automatically appear upon the occurrence of one or more conditions of engine alarm, colour may vary depending on the type of alarm:

**GREEN** alarm type **LOW**, self-diagnosis of the control unit has detected anomalies which are then resolved automatically.

**YELLOW** alarm type **MEDIUM**, the system alerts with visual and acoustic signals that there are abnormalities that must be kept under control, the machine must be taken to a service centre as soon as possible.

**RED** alarm type **HIGH**, the system warns with acoustic and visual signals that there are anomalies or serious situations, the error is saved.

### ALARM DESCRIPTION

**RED** alarm type **HIGH**, 3 beeps are emitted, the error is stored, the message remains on the display until manual reset is carried out by the operator.

### Message with red logo

This type of alarm is set for the following anomalies:

- 1) The engine has reached 110°;
- 2) Low engine oil pressure;
- 3) The machine has reached a vertical and/or horizontal gradient of 36°;
- 4) Presence of water in the fuel filter;
- 5) Motor rpm out of range;
- 6) High temperature of diesel fuel inside of the pump;
- 7) Clogged air filter;

Alarms type **HIGH**, excluding the control of horizontal and vertical inclination of the machine, affect engine power directly, reducing it to 60%.

### PLEASE NOTE:



If the engine reaches a temperature of 110°C, bring the rpm to minimum level and turn it off after a few minutes. **Do not turn off the engine immediately to avoid causing serious damage!**



## Operations and Maintenance





### LV600

**YELLOW** alarm type **MEDIUM** Two beeps are emitted, and the display shows timed Message with **YELLOW** logo. The error message remains large on the display for a few seconds and then returns to normal size. This type of alarm is set for the following anomalies:

- 1) alternator faulty;
- 2) Low battery;
- 3) scheduled maintenance due
  - Hydraulic oil and filter replacement 1000 hours;
  - Change the air filter 250 hours;
  - Engine service 500 hours;
- 4) hydraulic oil pressure below 18 bar;
- 5) fuel level below 30%;

#### CONTROL UNIT DISPLAY

	Low diesel	The warning light indicates the fuel level inside the tank.
	Working time	The display shows the working hours of the machine.





## LV600

### 2.2.5 REFUELLING DIESEL

Once the fuel warning light on the control panel has come on (see paragraph 2.2.4 of this manual), immediate refuelling is recommended. Lift the first bonnet using the elastic pin shown in fig. 11



Fig. 11

Find the fuel tank shown in fig. 12, open the plug by turning it counter-clockwise and fill up with fuel using a funnel, if necessary, to prevent the liquid from spilling.



Fig. 12

The only fuel types allowed are those shown in the table below. Fuel containing 10% methyl ester or B10 are suitable for use with this engine, provided that they comply with the specifications indicated in the table.



# Operations and Maintenance



## LV600

Fuel compatibility								
	Compatible		Warranty coverage		Engine deterioration		Emissions certification	
	YES	no	YES	no	YES	no	YES	no
EN 590, DIN 51628 - Military NATO fuel F-54 (S=10 ppm)								
Bio Fuels (EN14214)	(4)		(4)			(4)	(4)	
ARCTIC (EN 590/ASTM D 975)	(2)							
No 1 Diesel (US) - ASTM D 975 - Grade 1-D S 15 (S=15 ppm)								
No 1 Diesel (US) - ASTM D 975 - Grade 1-D S 500 (S=500 ppm)				(1)		(1)		
No 2 Diesel (US) - ASTM D 975 - Grade 2-D S 15								
No 2 Diesel (US) - ASTM D 975 - Grade 2-D S 1500				(1)		(1)		
High sulfur fuel < 5000 ppm (<0.5%)				(1)		(1)		
High sulfur fuel > 5000 ppm (>0.5%)				(3)		(3)		
High sulfur fuel > 10000 ppm (>1%)								
Civil Jet Fuels Jet A/A1								
Civil Jet Fuels Jet B								



### Caution!

Do not use vegetable oil as biofuel for this engine.



### Caution!

Damage caused by the use of fuels other than those recommended shall not be covered by warranty.



### Caution!

Do not wait for the tank to empty completely, which would cause the engine to stop. This could damage the engine and make subsequent starting difficult.



### Caution!

Do not smoke or use naked flames while refuelling, to prevent explosions or fires. These operations must be carried out only outdoors or in well ventilated areas as fuel fumes are highly toxic.



### Caution!

Do not release fuel in the environment as it is highly pollutant.



### Caution!

Do not fill the fuel tank completely to allow the fuel to expand.



C.da Sant'Onofrio, 6/A  
66034 Lanciano (CH) – ITALY  
Tel. (+39) 0872.50221 – Fax (+39) 0872.50231  
E-mail: [info@mdb srl.com](mailto:info@mdb srl.com) – Web: [www.mdb srl.com](http://www.mdb srl.com)



# Operations and Maintenance



## LV600



### Caution!

Fuel fumes are highly toxic, refuelling must be carried out only outdoors or in well-aired environments. Do not get too close to the cap with your face so as to avoid inhaling harmful



### Danger!

Top up only with the engine off.

### 2.2.6 CHECKING THE LEVEL, TOPPING UP AND CHANGING HYDRAULIC OIL

The hydraulic oil level must be topped up and checked with the vehicle not on a slope and with the engine stopped. Lift the machine hood using the elastic pin as shown in figure 11. Locate the hydraulic oil reservoir and the relative cap shown in fig. 13. To simply top up, remove the cap, pour in the oil while checking the maximum level indicator on the right side of the machine, next to the tank, and then screw the cap back on.

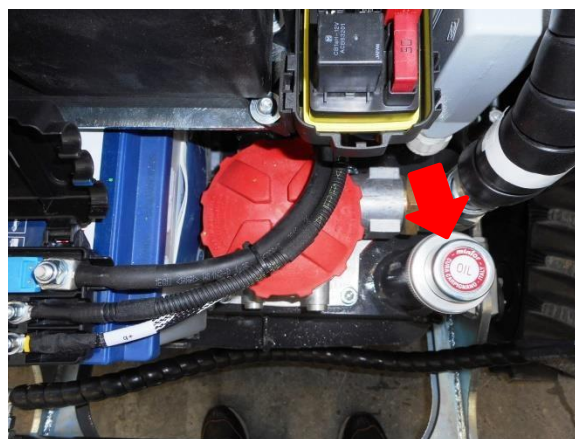

Fig. 13



## Operations and Maintenance



### LV600

To change the hydraulic oil completely, empty the tank with the engine warm, but stopped, so that the fluid drains away quickly and completely.



#### **Caution!**

Always wear protective gloves to protect the skin when carrying out these operations. Consult the safety data sheet of the oil you are using when choosing the right kind of gloves. The manufacturer recommends using AGIP OSO 46 oil.



#### **Caution!**

Do not release used oil in the environment as it is highly pollutant. Before starting up the machine again, make sure that the drain plug and filler cap are screwed on correctly in order to avoid lubricant spills.

**2.2.7 CHECKING AND TOPPING UP COOLANT** Checking and topping up the coolant should be carried out with the machine on a flat even surface, not sloping, and with the engine off and cold. Locate the radiator plug, fig. 14, at the back of the machine.



Fig. 14



## Operations and Maintenance



### LV600

Lift the cover as shown in fig. 15:



Fig. 15

To top up, unscrew the plug, pour the coolant up to the maximum level, screw the plug back on.



**Caution!**

Continuing to use the machine if there is a leak in the cooling circuit or the liquid level is too low, could cause irreparable machine damage. Locate the cause and repair the fault immediately before using the machine.



**Caution!**

The cooling fluid must be made up of: 50% ANTIFREEZE and 50% decalcified water.



**Caution!**

The fluid must cover the pipes inside the radiator by about 5mm. Do not fill the radiator completely but leave an adequate free space for expansion of the coolant.



## LV600

### 2.2.8 CHECKING THE ENGINE OIL LEVEL AND TOPPING UP

The engine oil level must be checked and refilled with the machine not on a slope and with the engine stopped and warm. After using the machine, stop the engine, wait at least 10 minutes before you begin the check and possible topping-up. Open the first hood by following the steps in Figure 11. Open the second hood by following the steps in Figure 16.



Fig. 16

Locate the dipstick for the oil level check B placed at the right side of the machine.

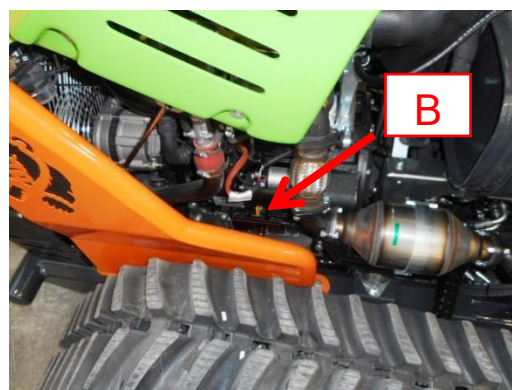



## Operations and Maintenance



### LV600

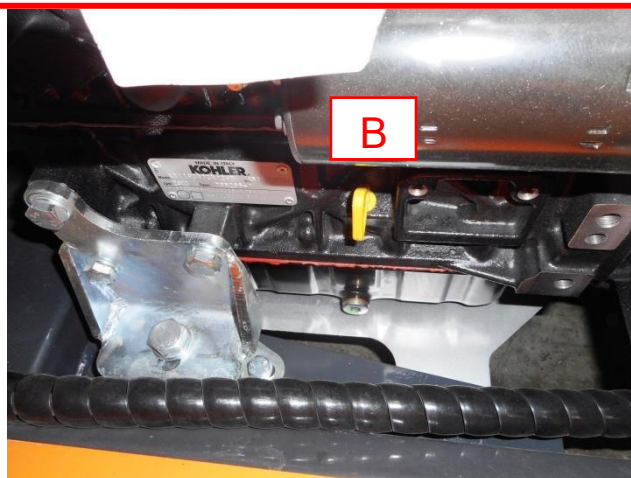

Remove the oil level check dipstick B and check that the level is close but not beyond MAX.

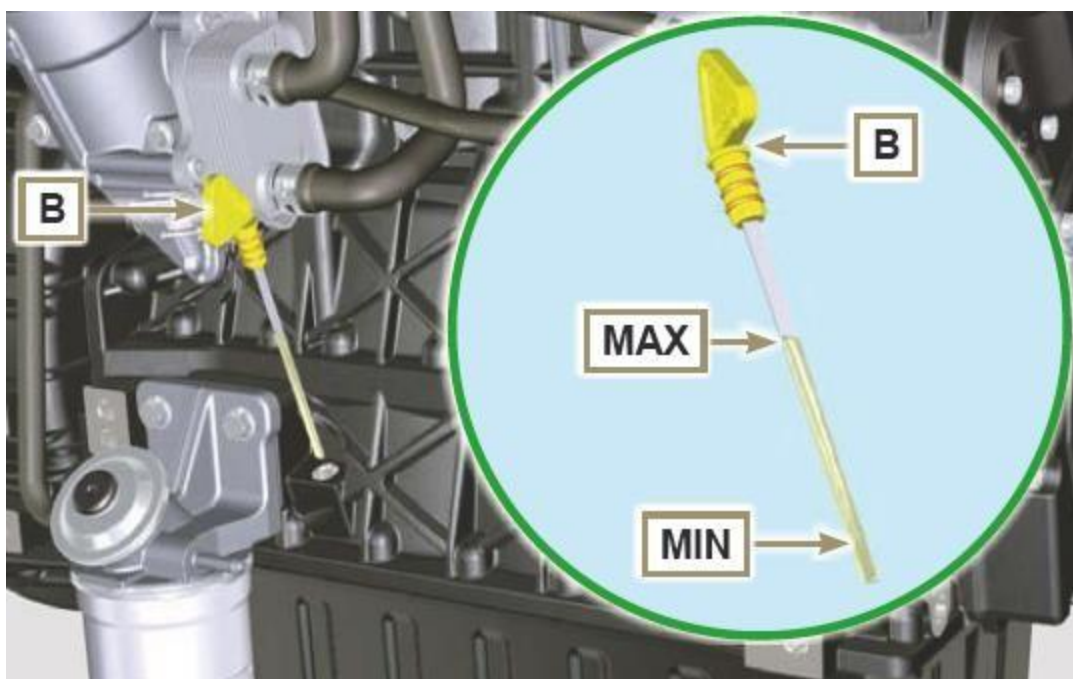

Refill if the level is not close to the MAX by unscrewing the oil filler plug A or the oil filler plug C if the plug A is not accessible. Reinsert the dipstick "B" correctly.



# Operations and Maintenance



## LV600

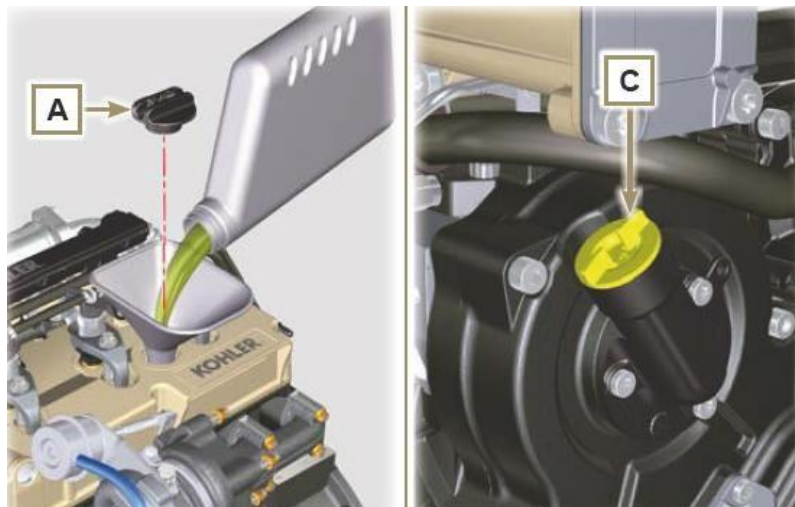

Use only oil with the properties listed in the table below:

Recommended oil			
Viscosity	SAE	15W-40 (-15°C ÷ +50°C) 10W-30 (-25°C ÷ +40°C) 10W-40 (-25°C ÷ +50°C) 5W-30 (-30°C ÷ +40°C) 0W-40 (-40°C ÷ +50°C)	
		TCR TIER IV FINAL - STAGE V <sup>(1)</sup>	TCR/D TIER III or NOT CERTIFIED <sup>(2)</sup>
with specifications	API	CJ-4 Low S.A.P.S	CI-4 Plus
			CI-4
	ACEA	E9 Mid S.A.P.S. E6 Low S.A.P.S.	E7
			E5

The oil viscosity must be adjusted to the temperature of the space in which the engine operates.



### **Caution!**

The engine may be damaged if operated with incorrect oil level. Never exceed the MAX level as its combustion can cause an abrupt increase in engine speed.



### **Caution!**

Use only the recommended oil in order to ensure adequate safety, efficiency and service life of the engine. Using an oil of lower quality than that recommended will greatly affect the engine service life.



C.da Sant'Onofrio, 6/A  
66034 Lanciano (CH) – ITALY  
Tel. (+39) 0872.50221 – Fax (+39) 0872.50231  
E-mail: [info@mdb srl.com](mailto:info@mdb srl.com) – Web: [www.mdb srl.com](http://www.mdb srl.com)





## LV600

### 2.2.9 CHECKING THE FUEL FILTER CARTRIDGE

When there is water in the fuel filter cartridge the machine emits 3 beeps, the red alarm signal appears on the control unit and the engine shuts down. Locate the fuel filter cartridge on the left side of the machine, after lifting the first and the second hoods as shown in figures 11 and 16.



- 1 - Slightly loosen the wing bolt A without taking it out.
- 2 - Drain water if present.
- 3 - Tighten the wing bolt A as soon as the fuel flows out.

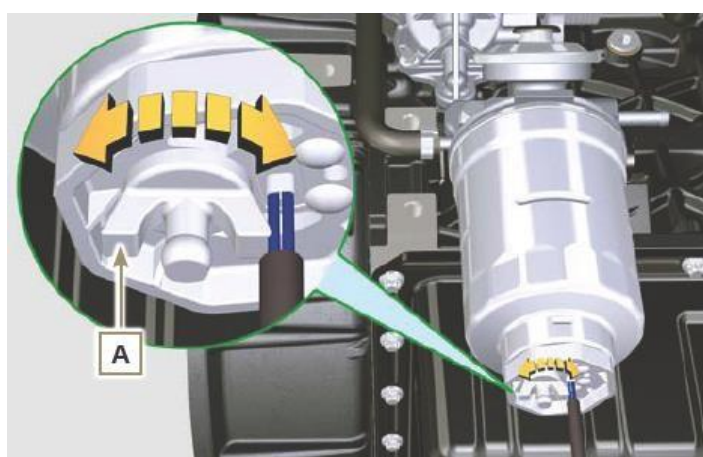



# Operations and Maintenance



## LV600

---

### LEGEND TO THE LABELS ON THE MACHINE

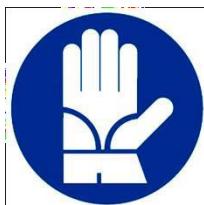

WEAR PROTECTIVE WORK GLOVES



CONSULT THE OPERATIONS AND  
MAINTENANCE MANUAL



USE PROTECTIVE FOOTWEAR



USE EAR PROTECTION EQUIPMENT



USE A HARD HAT



USE A PROTECTIVE FACE VISOR



USE WORK CLOTHING



# Operations and Maintenance



## LV600

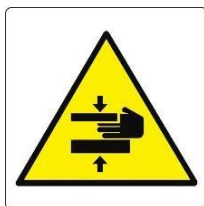

**DANGER: WATCH YOUR HANDS**



**DANGER: HIGH TEMPERATURE**



**DANGER OF CRUSHING AND COLLISION DO NOT STAND NEAR THE MACHINE. DO NOT OPERATE THE MACHINE STANDING BELOW IT ON STEEPLY SLOPING TERRAIN,**



**DANGER OF CONTACT WITH MOVING WORKING PARTS. DO NOT APPROACH THE MACHINE'S MOVING FLAILING PARTS, WITH THE TRANSMISSION CONNECTED AND THE ENGINE RUNNING. DO NOT WEAR LOOSE CLOTHING.**



**DANGER, DO NOT DIRECT WATER UNDER PRESSURE TOWARDS THE POINTS WHERE THERE IS THE FOLLOWING WARNING AND/OR AS INDICATED IN THIS MANUAL.**



### 3. MAINTENANCE AND TECHNICAL ASSISTANCE

The machine's reliability, safety and service life depend on its maintenance and technical assistance. Performing maintenance and technical assistance is not a recommendation, but something that the machine's owner is obliged to carry out.

The manager must make sure that the all maintenance is carried out according to the instructions in this manual, and in compliance with the applicable laws in force.

MDB does not assume any liability for damage to the machine or for accidents due to inadequate maintenance, inadequate technical assistance or failure to comply with the laws in force.

If components need to be replaced during repair or technical assistance, only MDB spare parts or parts authorised by MDB may be used. MDB does not assume any liability for damage to the machine or for accidents due to use of non-original parts.



#### **Important!**

Observe the maintenance and technical assistance instructions and frequency indicated by MDB. Lack of doing so will void any liability and warranty rights.

#### RESPONSIBILITIES AND DUTIES

TYPE OF OPERATION	REQUEST	CARRIED OUT BY
Maintenance	Owner	Owner/Operator/ MDB technical assistance centre
Technical Assistance	Owner	MDB technical assistance centre

Only use original MDB lubricants or lubricants compliant with the lubricant specifications given in this chapter.



# Operations and Maintenance



## LV600

### WORKING TIME COUNTER

The MDB control unit has a working time counter. The machine must be taken to the nearest technical assistance centre (\*) to undergo routine maintenance.

(\*) The technical assistance centres authorised by MDB are indicated at the end of this manual.



#### **Important!**

Observing the prescribed maintenance and technical assistance frequency increases the machine's service life and prevents the onset of unpredictable faults during its operation. Failure to observe the technical assistance frequency or if it is not carried out by an MDB authorised technical assistance centre, will void warranty rights.

## 3.1 MAINTENANCE MANUAL

Sequence of maintenance work: 1. Cleaning.

2. Visual inspection.

3. Lubrication and fluid level checks. 4.

Track maintenance.



#### **Important!**

Maintenance work must be carried out only by expert persons.

### 3.1.1 CLEANING



#### **Important!**

Proper cleaning increases the device's reliability and durability.



## Operations and Maintenance



### LV600

Only use only environmentally friendly, pH-neutral detergents that do not irritate the skin. This will protect the environment and avoid oxidising the device. Only clean in places that are suitable for washing (with oil separators). Do not use rags that could scratch or scrape.

#### CLEANING TASKS



#### **Caution!**

Wet or damp electrical components can cause the device to malfunction or create short circuits in the electronic systems.

Only clean the device when it is not connected to the power supply, every day or at least after each use.

#### High pressure cleaning:



#### **Caution!**

Failure to follow these instructions could damage the device.

- Instructions for use of the high-pressure washer.
- The water/detergent temperature must not exceed 60°.
- The nozzle must always be kept at a sufficient distance from the equipment.



- The water jet must never be  pointed towards:
  - ⇒ Electrical or electronic components (water entry).
  - ⇒ Plastic components (deformation, fracturing).



## Operations and Maintenance



### LV600

- ⇒ Bearings or support points (dirt and lubricant must be removed from the bearing).
- ⇒ Labels (they could be removed or become illegible).



#### **Caution!**

Clean and remove all residues that remain attached to the machine such as foliage, straw, grass and any other type of flammable material that could easily cause a fire at the end of each working day and after each use of the machine.

#### Cleaning the engine air filter:

The engine air filter should be cleaned every 10 hours of operation or at least every 6 months. The display of the control unit signals that the engine air filter is clogged with 2 beeps and a yellow alarm message. To clean the filter, remove the cover by releasing the two metal clips shown in fig. 17, take out the filter elements B and G, and use a damp cloth to remove the impurities from the inside of the parts A and D.

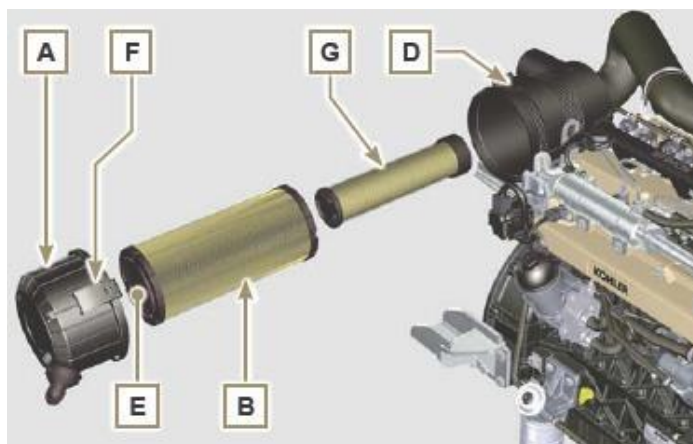
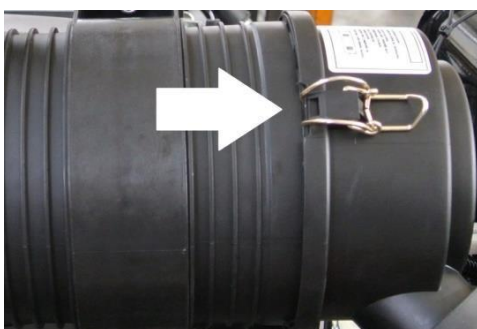

Fig. 17



#### **Caution!**

Do not use compressed air, slightly and repeatedly beat the front side "E" over a flat surface.



## Operations and Maintenance



### LV600



#### **Caution!**

When the "G" cartridge is dirty, do not clean but replace cartridges "B" and "G" before 50 hours of operation.

Once you have cleaned it, refit the filter element and close the protective cover with the two metal clips.

#### Intercooler and radiator exchange surface cleaning:

Intercooler and radiator exchange surface must be cleaned every day after the operation and more accurately after 250 hours of operation as per the maintenance schedule shown in paragraph 3.2 of this manual. Locate the radiator on the back of the machine. Open the cover by releasing the elastic clips shown in figure 18.







## Operations and Maintenance



### LV600



Fig. 18

The radiator exchange surface must be cleaned on both sides.



Check the exchange surfaces of the radiator and clean the surfaces with a brush soaked in a suitable detergent if they are clogged.



**Caution!**

Wear protective goggles if using compressed air.



## LV600

### 3.1.2 VISUAL INSPECTION



#### **Important!**

Missing, damaged or worn components must be replaced immediately.

Carry out the following checks daily before each use:

#### Clamping elements

- Check the safety systems, the working condition of the screws, deformation of the bolts and the necessary safety conditions.
- Tighten any loose screws/nuts.

Replace any missing or damaged fastening components immediately.

#### Steel components

- Cracks on the components, in particular in the welds and curved edges.
- Deformations.
- Corrosion.

#### Hydraulic system

- Complete hydraulic system (cables, pipes, cylinders, etc.) to check for leaks.
- Hydraulic lines for impacts, cracks, deformations.
- Leaking pipes, grease, dents, splits, porosity, etc.
- Hydraulic oil level.

#### Electrical system

- Cable integrity, dents, splits, porosity, etc.
- Sheathing for completeness, damage, etc.
- Control unit, switches, display, sensors for correct installation, damage, etc.

#### Labels

Check completeness and legibility.



C.da Sant'Onofrio, 6/A  
66034 Lanciano (CH) – ITALY  
Tel. (+39) 0872.50221 – Fax (+39) 0872.50231  
E-mail: [info@mdbsrl.com](mailto:info@mdbsrl.com) – Web: [www.mdbsrl.com](http://www.mdbsrl.com)



# Operations and Maintenance



## LV600

---

### Safety device checks

- Check emergency stop buttons operations.



### Danger!

Machines that do not stop when the emergency button is pressed can cause a high risk of fatal accidents.

Working with a defective emergency stop switch is gross negligence. Do not use the machine if the emergency button(s) does not work; contact the MDB assistance centre immediately.

### OPERATIONAL CHECK:

- Press any control lever on the radio remote control or on the control panel. The machine must move without problems.
- Press the emergency stop button with the machine in motion. First the one on board the machine, then perform the same check on the one on the radio remote control. The machine must stop with the engine off when the emergency button is pressed.
- Press any control lever again. The machine must not move.
- Release the emergency stop button. Operate the levers on the radio remote control and on the control panel: the machine must not move.
- Carry out the steps given in paragraph 2.2.1 of this manual: operating the control levers on the radio remote control or on the control panel, the machine should move.

### Checking the rubber pipes:

Check these elements according to the frequency indicated in the maintenance schedule in section 3.2 of the following manual. Checking must be carried out by applying slight pressure or bending of the pipe along its entire length and in the vicinity of the fixing clamps. The components must be replaced if they have cracks, cuts, leaks and do not have a certain degree of flexibility.



C.da Sant'Onofrio, 6/A  
66034 Lanciano (CH) – ITALY  
Tel. (+39) 0872.50221 – Fax (+39) 0872.50231  
E-mail: [info@mdbsrl.com](mailto:info@mdbsrl.com) – Web: [www.mdbsrl.com](http://www.mdbsrl.com)



# Operations and Maintenance



## LV600

Check if the following are intact:

- Pipes for fuel A circuit.
- Sleeves for cooling circuit B.
- Pipes for vent circuit C.
- Sleeves for air circuit D.
- Sleeves for oil return circuit E.

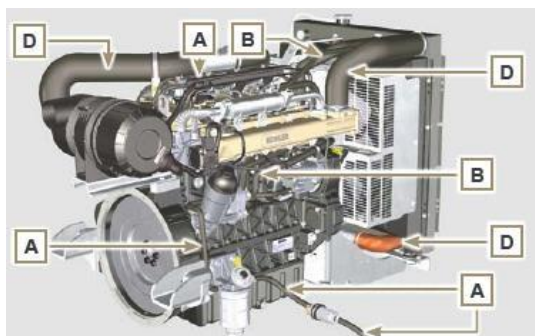

### 3.1.3 LUBRICATION

Grease every 8 hours and in any case after each wash.



#### **Important!**

MDB recommends using biodegradable lubricants.  
Do not mix different lubricants together.  
Even biodegradable greases must not be released into the environment.  
Lubricants must be free of solid residues. Do not use graphite-based lubricants.



#### **Caution!**

Failure to respect maintenance schedules, improper or lack of lubrication can damage the device and lead to high repair costs and downtime.



#### **Danger!**

The machine must not be operated in any way during lubrication as it would cause fatal danger.



# Operations and Maintenance



## LV600

Lubrication process:

- Thoroughly clean any old parts or parts covered in grease or impurities. Otherwise, any dirt from the old grease would be pressed onto the device's surfaces.



### Caution!

**In this application, the presence of dirt can quickly lead to wear, machine downtime and high repair costs.**

- Compress the grease onto the support point.
- After lubricating, remove any excess grease.
- Excess grease cannot be reused.
- Dispose of the excess grease in accordance with the applicable national laws.



### Caution!

**If you get lubricant in your eyes, rinse immediately with clean water and contact a doctor or go to the hospital! If you get lubricant on your skin, clean the affected area with clean water.**

## CHANGING THE HYDRAULIC OIL, HYDRAULIC OIL MAINTENANCE

Replacing the hydraulic oil

The hydraulic oil must be changed after the first 500 hours of operation, and then every 2000 hours of operation or at least once a year.

Hydraulic oil maintenance



### Important note!

**Annual oil maintenance greatly extends the oil change intervals.**

**This means a reduction in costs for the user company, but**



C.da Sant'Onofrio, 6/A  
66034 Lanciano (CH) – ITALY  
Tel. (+39) 0872.50221 – Fax (+39) 0872.50231  
E-mail: [info@mdbsrl.com](mailto:info@mdbsrl.com) – Web: [www.mdbsrl.com](http://www.mdbsrl.com)



# Operations and Maintenance



## LV600

also a reduction in costs for the disposal of used oils and a reduction in pollution.

Oil maintenance must be carried out each year by the MDB authorised support centre.

Oil maintenance consists of the following:

- Filtering the oil.
- Eliminating the water.
- Checking the oil's purity.
- Replacing the filter.

Hydraulic oil



**Important!**

MDB recommends using ENI OSO 46 oil.



**Important!**

Maintenance and oil changes must be carried out as described in paragraph 2.2.5 of this manual.

START

Check the engine oil level using the dipstick following the steps indicated in section 2.2.5 at the end of each working day.

### 3.1.4 TRACK MAINTENANCE

DAILY MAINTENANCE

- Check the track tension (see the following paragraphs).
- Check that the gear motors function properly.
- Check the track wear and condition.



**Caution!**

Replace the tracks when there is 10 mm of tread left, or before if there are cuts.



C.da Sant'Onofrio, 6/A  
66034 Lanciano (CH) – ITALY  
Tel. (+39) 0872.50221 – Fax (+39) 0872.50231  
E-mail: [info@mdbsrl.com](mailto:info@mdbsrl.com) – Web: [www.mdbsrl.com](http://www.mdbsrl.com)



## Operations and Maintenance



### LV600

- Check that there are no foreign bodies between the rollers and the tracks, between the idle wheels and the tracks, or between the drive wheels and the tracks.

#### MONTHLY MAINTENANCE

- Visually check the roller mountings.
- Check for any play in the bearings.

#### TENSIONING THE TRACKS

The tracks must be tensioned if the track backlash is greater than 1 cm.

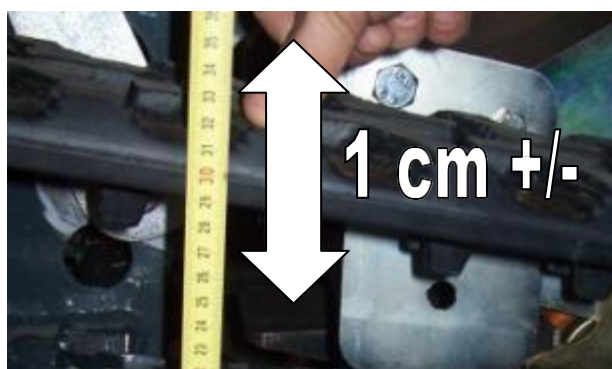

This check must be carried out daily, especially when the tracks are new and the rubber covering the ground chain starts to wear (pay particular attention during the first 10 hours of operation).

Remove the black undercarriage covers:



Locate the track tensioner cylinder lubrication unit.



C.da Sant'Onofrio, 6/A  
66034 Lanciano (CH) – ITALY  
Tel. (+39) 0872.50221 – Fax (+39) 0872.50231  
E-mail: [info@mdbsrl.com](mailto:info@mdbsrl.com) – Web: [www.mdbsrl.com](http://www.mdbsrl.com)



## Operations and Maintenance



### LV600

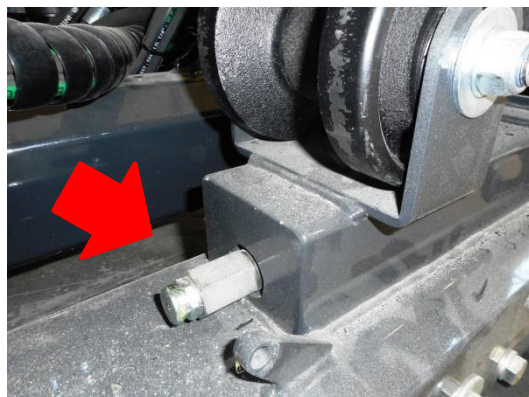

Connect the grease pump to the track tensioner lubrication unit.



#### Caution!

The grease pump must be equipped with a pressure gauge with scale up to 200 bar (see picture below).



Lubricate up to a pressure of 160 bar.





## LV600

### 3.2 TECHNICAL ASSISTANCE



**Important note!**

Technical assistance can only be carried out by MDB authorised assistance centres. Otherwise, any form of warranty is lost.

See the machine operating time on the control unit display to schedule technical assistance.

The owner of the machine must start to schedule machine maintenance when the counter shows a use of 0 to 10 hours. Keep a logbook of the maintenance carried out. All maintenance and repairs must be recorded in the logbook and must be signed and stamped by the MDB authorised assistance centre.

#### Maintenance service symbols

Functional test	
Replacement	
Visual inspection	
Screw tightness check	
Cleaning	









# Operations and Maintenance







## LV600

### FIRST TECHNICAL ASSISTANCE AFTER 10 HOURS OF OPERATION OR 6 MONTHS

Name	Action
Engine oil level	
Coolant level	
Air filter	 
Rubber pipes	
Check the tension of the nuts and tighten them	
Tensioning of the tracks	



### EVERY 10 HOURS OF OPERATION OR AT LEAST EVERY 6 MONTHS

Name	Action
Air filter	 
Rubber pipes	
Engine oil level	

### EVERY 50 HOURS OF OPERATION OR AT LEAST ONCE A YEAR

Name	Action
Battery check	

### EVERY 125 HOURS OF OPERATION OR AT LEAST ONCE A YEAR

Name	Action
Tracks: wear, condition of links, pins, lower rollers	
Tightening the track screws	



C.da Sant'Onofrio, 6/A  
 66034 Lanciano (CH) – ITALY  
 Tel. (+39) 0872.50221 – Fax (+39) 0872.50231  
 E-mail: [info@mdb srl.com](mailto:info@mdb srl.com) – Web: [www.mdb srl.com](http://www.mdb srl.com)



# Operations and Maintenance



## LV600

EVERY 250 HOURS OF OPERATION OR AT LEAST EVERY 6 MONTHS

Name	Action
Radiator exchange and intercooler surface	
Alternator belt tensioning	

AFTER 500 HOURS OF OPERATION OR AT LEAST AFTER ONE YEAR

Name	Action
Hydraulic oil	
Hydraulic oil filter cartridge	

EVERY 500 HOURS OF OPERATION OR AT LEAST ONCE A YEAR

Name	Action
Engine oil	
Engine oil filter cartridge	
Fuel filter cartridge	
Alternator belt	
Remote control	
All safety devices	
Pump capacity - rpm	
Electrical lines/hydraulic pipes, tighten the screw clamps	



C.da Sant'Onofrio, 6/A  
 66034 Lanciano (CH) – ITALY  
 Tel. (+39) 0872.50221 – Fax (+39) 0872.50231  
 E-mail: [info@mdbsrl.com](mailto:info@mdbsrl.com) – Web: [www.mdbsrl.com](http://www.mdbsrl.com)



# Operations and Maintenance



## LV600

Control levers, control bars	
Rubber sleeves (air/coolant intake)	
Fuel pipes	

### EVERY 1000 HOURS OF OPERATION

Name	Action
Fuel tank	
Rubber air filter intake sleeves	
Hydraulic piping	
Hydraulic oil filter cartridge	
Coolant fluid	
Coolant sleeves	

### EVERY 1500 HOURS OF OPERATION

Name	Action
Fuel pipes	

### EVERY 2000 HOURS OF OPERATION OR AT LEAST ONCE EVERY 2 YEARS

Name	Action
Hydraulic oil	
Hydraulic oil tank	







## Operations and Maintenance



### LV600

EVERY 5000 HOURS OF OPERATION

Name	Action
Starter engine	 
Alternator	 

TRACK TREAD HEIGHT  $\leq$  10 mm

Description	Action
Tracks	



## LV600

### 3.2.1 RELAY AND FUSE POSITION DIAGRAM

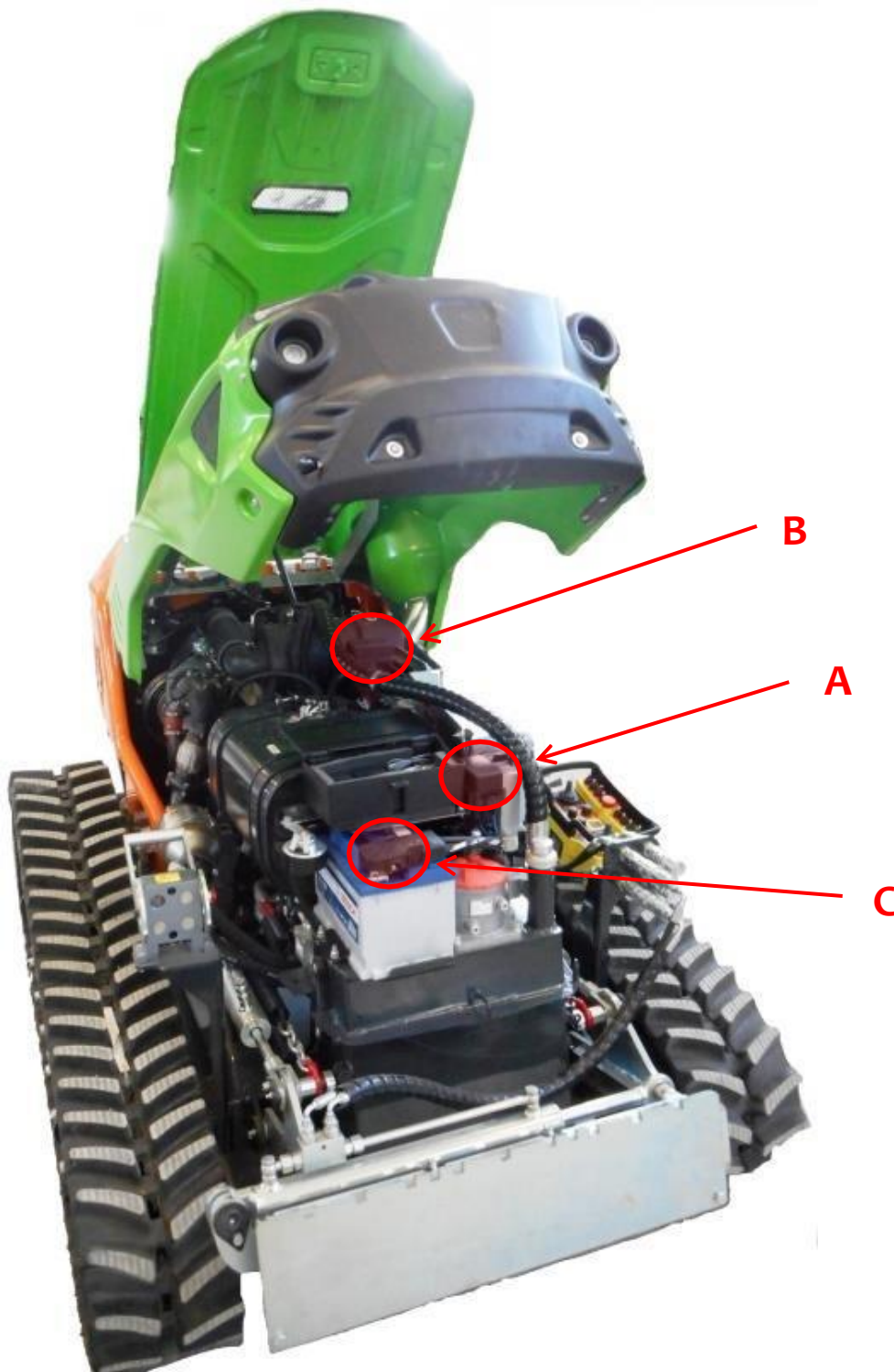



# Operations and Maintenance



## LV600

### A – RELAYS AND FUSES – MISCELLANEOUS SERVICES



#### COMPONENT “A” LEGEND:



- F1 (5A) DISPLAY
- F2 (5A) - HORN
- F3 (5A) - CLEARANCE LIGHTS
- F4 (5A) - BATTERY CHARGER
- F5 (20A) CLEANER
- F6 (5A) - LIGHTS



R1- LIGHTS



R2 - HEATER

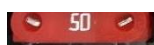

F7 (50A) - HEATER



R3 - CLEANER



# Operations and Maintenance



## LV600

### B-MOTOR RELAYS AND FUSES UP TO THE S/N \*0246\* MACHINE



COMPONENT "B" LEGEND:



- F1 (20A) - MAIN
- F2 (20A) STARTER + A.C. PUMP F3 (5A) ECU B
- F3 (5A) - ECU B
- F4 (5A) - EGR
- F5 (15A) - SWITCHBOARD POWER SUPPLY
- F6 (3A) - OBD II



- R1 - MAIN
- R2 - STARTER
- F7 - MAIN
- R3 - A.C. PUMP

### B-MOTOR RELAYS AND FUSES OF THE S/N \*0247\* MACHINE

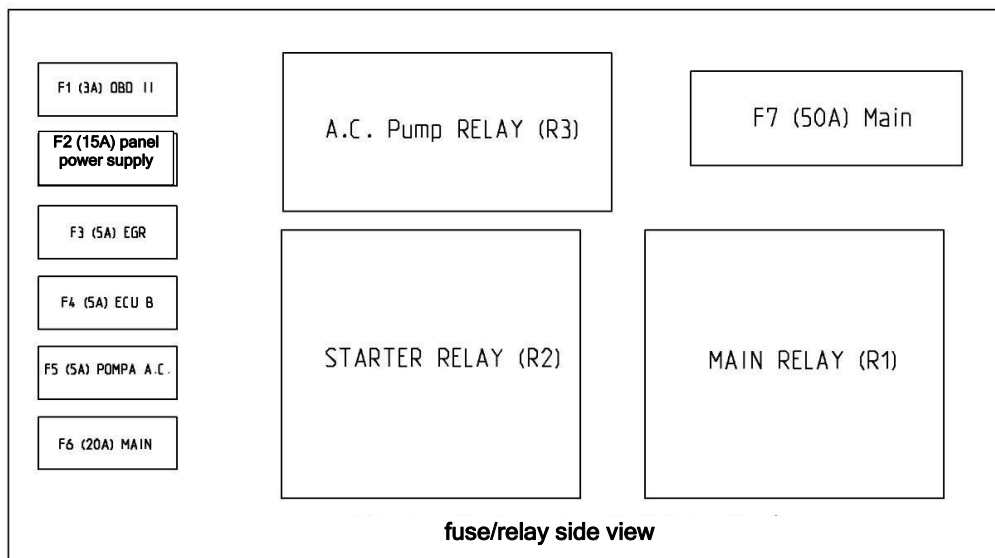

**Important!**



Fuses and relays must be replaced only with original Kohler parts.  
**Parts other than the original ones can permanently damage the engine and/or its components!**

≡



C.da Sant'Onofrio, 6/A  
66034 Lanciano (CH) - ITALY  
Tel. (+39) 0872.50221 - Fax (+39) 0872.50231  
E-mail: [info@mdbsrl.com](mailto:info@mdbsrl.com) - Web:





## Operations and Maintenance



### LV600

#### C - FUSES - MISCELLANEOUS SERVICES

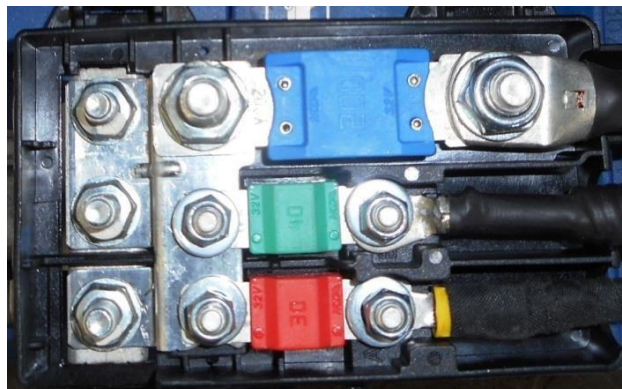

#### COMPONENT "C" LEGEND:

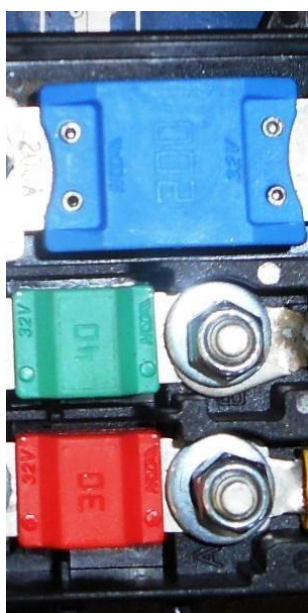

F1 (200A) - START MOTOR

F2 (40A) - POWER SUPPLY OF LOMBARDINI SYSTEM

F3 (30A) - POWER SUPPLY OF ELECTRIC SYSTEM



# Operations and Maintenance



## LV600

### 3.2.2 PROBLEM SOLVING GUIDE

REMOTE CONTROL		
PROBLEM	CAUSE	SOLUTION
1 Radio remote control not working	Flat battery	Recharge the battery
	Radio remote control connection not made	Connect transmitter - receiver
	Emergency button pressed	Release the emergency button
	Electronic key not inserted	Insert the electronic key
	Transmitter with different serial number from receiver	Use a transmitter with the same serial number as the receiver
1.1 Radio remote control not working: RF busy LED flashing or off	Lack of radio signal	Check aerial connection
	Interference from other radio signals	Use only one machine at a time
	Interference from other radio signals	Use emergency electrical cable
1.2 Radio remote control not working: Power supply LED off	Fuse blown	Replace the receiver fuse
	Flat battery	Recharge the battery
1.3 Remote control not working: Power supply LED flashes intermittently	Shredder command on	Turn off flail mower
	Accelerator pedal activated	Turn off the accelerator pedal
1.4 RADIO REMOTE CONTROL battery on the machine does not charge	Battery charger cables disconnected	Connect the battery charger cables



## Operations and Maintenance



### LV600

TRACKS		
PROBLEM	CAUSE	SOLUTION
2 Track has come off	Tracks excessively worn	Replace the tracks
	Metal track structure broken	
	Insufficient track tension	Tension the tracks
2.1 Tracks loose	Rubber worn	Tension the tracks
	Insufficient track tension	
	Tensioning system broken	Contact the dealer

BEEPER / HORN		
PROBLEM	CAUSE	SOLUTION
3 Intermittent signal while driving	Fuel running out	Fill the tank
	Alternator problem	Contact the dealer
	Routine maintenance expired	Carry out maintenance as indicated in the operations and maintenance manual
3.1 Intermittent signal and	Low oil level	Do not use the machine until the cause of the problem is found as there is a risk of causing greater damage. Contact the dealer
	High engine temperature	



# Operations and Maintenance



## LV600

KOHLER ENGINE		
PROBLEM	CAUSE	SOLUTION
4 Yellow LED on	Engine ECU has detected faulty operation	Please contact your authorised KOHLER workshop
4.1 The engine does not start	Battery terminals sulfation	Clean the battery terminals
	Low battery voltage	Recharge the battery or replace it
	Low fuel level	Refill with fuel
	Frozen fuel	Contact Kohler authorised workshops
	Fuel filter clogged	Replace with a new filter
	Air inside the fuel circuit	Contact Kohler authorised workshops
	Clogged air filter	Replace with a new filter / clean
	Clogged pipes	Contact Kohler authorised workshops
	Fuse blown	Replace with new fuse. If the problem persists please contact your authorised KOHLER workshop
4.2 The engine turns on and then off	Clogged intake or drainage	Contact Kohler authorised workshops
	Faulty electrical connections	clean the electrical connections. If the problem persists please contact your authorised KOHLER workshop
	Battery terminals sulfation	Clean the battery terminals
	Fuel filter clogged	Replace with a new filter and clean the tank
4.3 Minimum rpm unstable	Fuel pipes clogged	Contact Kohler authorised workshops
	Fuel pipes clogged	Please contact your authorised KOHLER workshop
4.4 Minimum rpm low	Fuel pipes clogged	Contact Kohler authorised workshops
	Low quality fuel	Clean the tank and refill with high quality fuel
4.5 BLUE smoke	Oil level in the cup high	Replace the engine oil. If the problem persists please contact your authorised KOHLER workshop
	Clogged air filter	Replace with a new filter



C.da Sant'Onofrio, 6/A  
 66034 Lanciano (CH) – ITALY  
 Tel. (+39) 0872.50221 – Fax (+39) 0872.50231  
 E-mail: [info@mdb srl.com](mailto:info@mdb srl.com) – Web: [www.mdb srl.com](http://www.mdb srl.com)



## Operations and Maintenance



### LV600

4.6 Excessive consumption of fuel	Clogged air filter	Replace with a new filter
	Oil level in the cup high	Replace the engine oil. If the problem persists please contact your authorised KOHLER workshop
4.7 The engine has lost its initial performance	Clogged air filter	Replace with a new filter
	Fuel pipes clogged	Please contact your authorised KOHLER workshop
	Low quality fuel	Clean the tank and refill with high quality fuel
	Oil level in the cup high	Replace engine oil and if the problem persists please contact your authorised KOHLER workshop
4.8 The engine has acceleration gaps	Fuel filter clogged	Replace the fuel filter
4.9 The engine has acceleration gaps	Fuel pipes clogged	Please contact your authorised KOHLER workshop
4.10 Engine overheats	Low coolant level	Top up
	Oil level in the cup high	Replace engine oil. If the problem persists please contact your authorised KOHLER workshop
	Radiator clogged	Clean the radiator and if the problem persists please contact your authorised KOHLER workshop



# Operations and Maintenance



## LV600

### ATTACHMENT A

## FACSIMILE DECLARATION OF CE CONFORMITY



DICHIARAZIONE NR. \_\_\_/\_\_\_

### DICHIARAZIONE CONFORMITÀ CE

(secondo l'allegato II punto A della Direttiva 2006/42/CE)

Il sottoscritto Mario Di Biase legale rappresentante della ditta MDB S.R.L., avente sede legale in Lanciano (CH) in C.da S. Onofrio, 6/A - Italia, costruttrice della seguente macchina: APRIPISTA MULTIFUNZIONE RADIOCOMANDATO

DESIGNAZIONE	TRATTRICE SEMOVENTE
SERIE	GREEN CLIMBER
MODELLO	LV600
MATRICOLA	_____
POTENZA MOTORE KOHLER KD1903TCR/26B	42 kW
RADIOCOMANDO IMET	M880-THOR2 B2N-10388-00
ANNO COSTRUZIONE	_____

equipaggiata con la seguente attrezzatura:

TIPO / MODELLO: _____	MATRICOLA: _____
-----------------------	------------------

DICHIARA sotto la propria personale responsabilità

CHE ESSA È CONFORME ALLE DIRETTIVE:

2006/42/CE (Macchine) recepita in Italia dal D. Lgs n.17/10, 2014/35/CE (Bassa Tensione) recepita in Italia dal D. Lgs n.86/16, 2014/30/UE (EMC) recepita in Italia dal D. Lgs n.80/16,2000/14/CE art. 12 All. I n. 16 e 2005/88/CE (Emissione Acustica Ambientale) recepita in Italia dal D. Lgs n.262/02

ED ALLE NORME ARMONIZZATE:

EN ISO 12100:2010, EN 60204-1:2006 + AC:2010, EN 349:1993+A1:2008, EN ISO 13857:2008; EN ISO 4254-1:2013, EN ISO 16231-1:2013, EN ISO 4254-7:2010, EN ISO 4254-12:2012, EN ISO 5395-1:2013, EN ISO 3744:1995, ISO 6395:1988, (per quanto applicabili)

La procedura 2 di valutazione è conforme all'allegato VI della Direttiva 2000/14/CE ed è stata effettuata dall'organismo notificato:

VERICERT S.r.l. - ORGANISMO NOTIFICATO EUROPEO n. 1878  
Via L. Masotti, 5 - 48124 Fornace Zarattini - Ravenna - ITALIA

che ha emesso il certificato di esame n° 1878EA048CT1017 in data 11 / 10 / 2017

Valore del livello di potenza sonora misurato: LWA = 97 dB(A)  
Valore del livello di potenza sonora garantito: LWA = 100 dB(A)

Persona autorizzata a costituire il fascicolo tecnico è il Sig. Mario Di Biase, residente in Lanciano (CH), C.da S. Onofrio, 6/A.

Le attrezzature applicabili al Green Climber LV600 autorizzate dalla MDB S.r.l., coperte dalla seguente dichiarazione di conformità CE sono:

TRINCIA UTD/130 - FRESA CS/135 - ATOMIZZATORE BV300 - FRESATRONCHI FTR400 - TURBINA NEVE DS/14 - TOSAERBA SRM/215  
Sono escluse dall'ambito di questa dichiarazione le attrezzature non espressamente specificate.

DECLINA

ogni responsabilità per sinistri a persone o a cose derivanti da manomissione della macchina da parte di terzi, ovvero da carenza di manutenzione o riparazione.

Lanciano, \_\_\_/\_\_\_/\_\_\_

Il Responsabile Legale MDB S.r.l.

Sig. Mario Di Biase  
M D B s.r.l.  
C.da S. Onofrio, 6/A  
66034 LANCIANO (CH)  
Partita IVA 01960690699

Sede legale:  
MDB Srl  
loc. C.da Sant'Onofrio 6/A  
66034 Lanciano (CH) Italy  
P.Iva IT01960690699  
Web: [www.mdb srl.com](http://www.mdb srl.com)

Sede produttiva e destinazione merci:  
MDB Srl  
Via Cupone 13  
66022 Fossacesia (CH) Italy  
Tel. +39 0872 50221 - Fax +39 0872 50231

AZIENDA CON SISTEMA  
DI GESTIONE QUALITÀ  
CERTIFICATO DA DNV GL  
= ISO 9001 =



C.da Sant'Onofrio, 6/A  
66034 Lanciano (CH) - ITALY  
Tel. (+39) 0872.50221 - Fax (+39) 0872.50231  
E-mail: [info@mdbsrl.com](mailto:info@mdbsrl.com) - Web: [www.mdb srl.com](http://www.mdb srl.com)



**Operations and Maintenance**

**LV600**



**ATTACHMENT B**

# HOW TO USE THE UTD-130 SHREDDER UTD-125 SHREDDER



C.da Sant'Onofrio, 6/A  
66034 Lanciano (CH) – ITALY  
Tel. (+39) 0872.50221 – Fax (+39) 0872.50231  
E-mail: [info@mdb srl.com](mailto:info@mdb srl.com) – Web: [www.mdb srl.com](http://www.mdb srl.com)



## Operations and Maintenance



### LV600

#### B.1 FOREWORD

As described on pages 16, 17 and 18 of this manual, the LV600 has been designed to be used with equipment applied to the front of the machine by means of a quick coupling plate. The UTD-130 FLAIL equipment is one of these. The user must note that only the equipment listed on page 18 can be applied to the LV600. MDB declines any liability if equipment other than that listed in this manual, or in any case not authorised by MDB, is applied to the LV600.

The LV600 can be delivered to the purchaser with the FLAIL already installed. Once arrived at destination, the attachment points on the machine must be used to position it, which are located in the areas indicated in the photos below.







## Operations and Maintenance



### LV600

---

#### B.2 HOW TO FIX THE EQUIPMENT TO THE MACHINE

If the LV600 is delivered with the FLAIL MOWER disconnected from the machine, proceed as follows to apply the FLAIL to the LV600: 1- align the LV600 to the flail mower following the steps in fig. 19;



Fig. 19

2- press the red button (fig. 20);

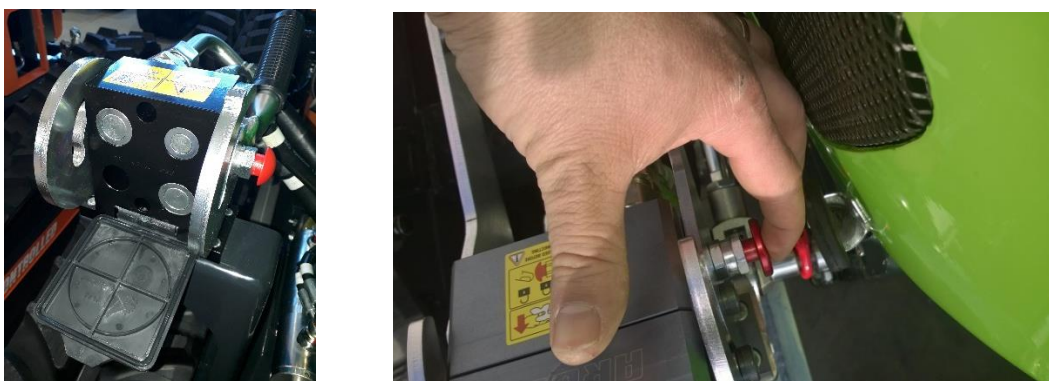

Fig. 20



## Operations and Maintenance



### LV600

3- attach the hydraulic pipes as shown in Fig. 21;

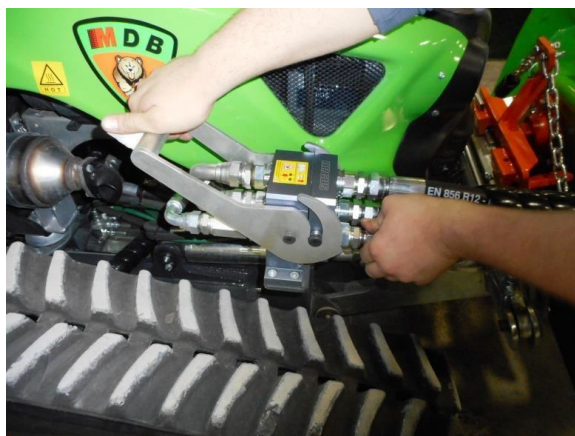
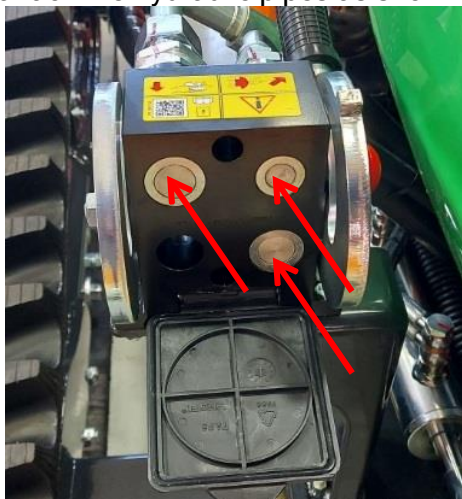
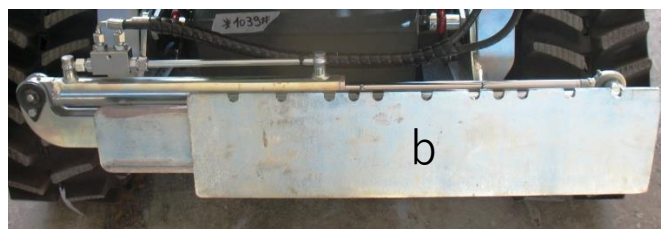

Fig. 21

4- bring the orange plate (a) on the flail mower up to the plate on the LV600 (b), resting the guides on the flail mower plate (c) on top of the LV600 plate (Fig. 22);





## Operations and Maintenance



### LV600



Fig. 22

5- lift the lever to lock the FLAIL to the LV600 plate (fig. 23);



Fig. 23

The LV600 Shredder is now ready for use.



C.da Sant'Onofrio, 6/A  
66034 Lanciano (CH) – ITALY  
Tel. (+39) 0872.50221 – Fax (+39) 0872.50231  
E-mail: [info@mdbsrl.com](mailto:info@mdbsrl.com) – Web: [www.mdbsrl.com](http://www.mdbsrl.com)



## Operations and Maintenance



### LV600

To release the equipment from the LV600 , perform the above attachment operations in reverse order.

#### B.3 HOW TO USE THE LV600 FLAIL MOWER SERIES UTD-130

The controls and operation of the LV600 with the UTD-130 Flail Mower are those described for the basic machine. Refer to Chapter 2.2 of this manual.

The -8- control on the radio remote control (paragraph 2.2 of this manual), auxiliary control for equipment applied to the LV600, is not used with the FLAIL MOWER.



**Danger!**  
If equipment is installed on the machine, do not operate it from the front, always stay behind it.



**Danger!**  
Before using the machine with the flail mower, always check the area where it will be used. Have unauthorised persons and animals move away, mark out the work area using suitable barriers and make sure that unauthorised persons cannot enter the enclosed area.  
Persons, animals and vehicles must not remain and/or transit near the machine while it is in operation.



**Caution!**  
With equipment mounted on the machine, there is a hazard to the operator's body and face from blunt objects being projected from the front area of the machine. Always wear the PPE indicated in this manual and on the labels on the machine. Always use as intended and follow safe practices, remaining behind the machine and **NEVER** in front of it. Do not fail to comply with this obligation for any reason.





# Operations and Maintenance



## LV600



### **Danger!**

On steep terrain, never stand or manoeuvre the machine from a position in the area below it, as the machine could overturn in this area. Always stand or manoeuvre the machine from the area above it.



### **Caution!**

With the equipment attached, there is danger of contact with moving parts at the front of the machine.

Do not approach the machine's flailing parts when they are in motion, with the transmission connected and the engine running.

Do not wear loose clothing that could get entangled in the moving parts.





# Operations and Maintenance



## LV600

# LOGBOOK

## ROUTINE MAINTENANCE

MACHINE MODEL	LV600
SERIAL NUMBER	
YEAR OF MANUFACTURE	

Date	Maintenance after 10 hours of operation	Performed by	Signature and Stamp

Date	Maintenance after 50 hours of operation	Performed by	Signature and Stamp

Date	Maintenance after 500 hours of operation	Performed by	Signature and Stamp



# Operations and Maintenance



## LV600

---

Date	Maintenance every 10 hours of operation	Performed by	Signature and Stamp



# Operations and Maintenance

## LV600



---





# Operations and Maintenance



## LV600

---



# Operations and Maintenance



## LV600

---



# Operations and Maintenance



## LV600

---



# Operations and Maintenance



## LV600

---

Date	Maintenance every 50 hours of operation	Performed by	Signature and Stamp



# Operations and Maintenance



## LV600

---



# Operations and Maintenance



## LV600

---



# Operations and Maintenance



## LV600

---

Date	Maintenance every 125 hours of operation	Performed by	Signature and Stamp



# Operations and Maintenance



## LV600

---





# Operations and Maintenance



## LV600

---



# Operations and Maintenance



## LV600

---

Date	Maintenance every 500 hours of operation	Performed by	Signature and Stamp



# Operations and Maintenance



## LV600

---

Date	Maintenance every 1000 hours of operation	Performed by	Signature and Stamp



# Operations and Maintenance



## LV600

---

Date	Maintenance every 1500 hours of operation	Performed by	Signature and Stamp





# Operations and Maintenance



## LV600

---

Date	Maintenance every 5000 hours of operation	Performed by	Signature and Stamp



# Operations and Maintenance



## LV600

### UNSCHEDULED MAINTENANCE

Date	Reason for the maintenance	Performed by	Signature and Stamp



# Operations and Maintenance



## LV600

---

Date	Reason for the maintenance	Performed by	Signature and Stamp