



FARMMA®

Lumber trailers

EN_V2.1-2016

Original

Instruction manual

CONTENTS

1	INTRODUCTION	3
2	SAFETY REGULATIONS	4
2.1	DESCRIPTION FOR THE USE OF WARNING SYMBOLS	4
2.2	GENERAL SAFETY REGULATIONS	4
2.3	INSTRUCTIONS FOR SAFE USE	4
2.4	LOCATION OF DECALS ON THE TRAILER	6
2.5	PRESENTATION OF DECALS	6
3	INSTRUCTIONS FOR SAFE USE	9
3.1	TECHNICAL DESCRIPTION	9
3.2	LOADING THE TOWING EYELET	9
3.3	TIGHTENING TORQUES	10
3.4	AIR PRESSURE IN THE TYRES	10
4	THINGS TO CONSIDER BEFORE AND WHEN DRIVING	11
4.1	CONNECTING THE TRAILER	11
4.2	DISCONNECTING THE TRAILER	11
4.3	TEST DRIVING THE TRAILER	12
4.4	OPERATING INSTRUCTIONS	12
5	MAINTENANCE/SERVICE	14



1 INTRODUCTION

This instruction manual is intended for FARMA lumber trailers, and contains information for safe use. FARMA lumber trailers are intended for self-employed work in the fields of agriculture and forestry. When working with the trailer, large forces are handled when moving heavy masses. The permitted load values may not be exceeded under any circumstances. See the instruction manual for information about permitted loads.

Even if you have experience of this type of product, we recommend that you read our instructions carefully in order to familiarise yourself with the product. The instructions contain information that is vital for safety and efficiency, as well as to ensure the validity of the factory guarantee. When the product you have purchased is delivered, check that it has not sustained any delivery or transport damage. If there should be any such damage, or if any parts are missing, contact your dealer immediately.

It is the responsibility of the user to inform himself regarding the use of the product and to follow the instructions carefully. It is also the responsibility of the user to ensure that attachments and connections to the vehicle are designed and adapted in such a way that they achieve what the trailer is intended to handle by a clear margin.

Fors MW reserves the right to make changes to equipment and maintenance instructions and to revise its data without prior notice.

Fors MW conforms to ISO 7010 for safety marking in accordance with the EC directive 2006/42/EC.

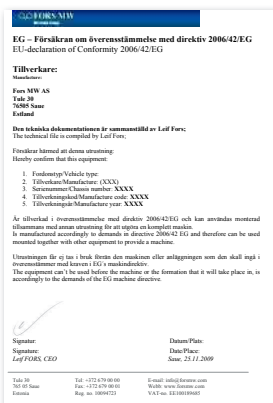

Manufacturer:

AS FORS MW
 TULE 30
 765 05 SAUE
 Tel: + 372 679 00 00
 www.forsmw.com

Dealer:

2 SAFETY REGULATIONS

2.1 Description of the use of warning symbols

In the instruction manual, we distinguish between the terms Warning and Note. These markings are used to draw the attention of readers to the fact that this is an area that is of particular importance.

Warning! = A very important item of safety information is supplied with this warning symbol. Warnings refer to the risk of injury or death for people, as well as the risk of serious damage to the equipment.

Note: = The Note symbol indicates that the product, process or environment may sustain damage, as well as indicating the risk of minor injuries.

2.2 General safety regulations



Carefully read through the instruction manual before using the lumber trailer. Important data relating to your particular trailer can be found in the trailer's technical data. Incorrect usage can result in injuries to you and damage to the machinery.

Operating a lumber trailer requires a high level of expertise, as well as knowledge about the machine you are using. It is important for you to acquire knowledge and to train with regard to the trailer's behaviour. Take care to ensure that nobody is within the safety zone (20 m). When working with the trailer, large forces are used to handle heavy masses. By adhering to the indicated safety regulations and the trailer's technical data, neither the user's nor the machine's safety are put at risk.

FARMA lumber trailers are intended for normal use within agriculture and forestry, and may only be used by individuals who possess general knowledge about the handling of agricultural machinery.

2.3 Instructions for safe use



Risk zone 20 metres.



When using a lumber trailer, the tractor must always be equipped with protective grilles in front of the rear windshield and at both side windows.



Never leave the tractor cab unless the tractor's brakes are applied and the engine is switched off.



In the event of a rotating axle – Do not walk over this or move under the trailer's drawbar when the hydraulic pump is in operation.

- Do not use the lumber trailer until you are sure you have mastered the machine.
- Test drive the machine before starting to use it.
- When travelling on public roads, lights must always be present on the trailer and must be used.
- When travelling on public roads, the trailer must by law always be supplied with an LGV sign.
- A country's laws and regulations must always be complied with. It is up to the user to ensure that this takes place. Areas that can be affected include the brakes and the lights.
- Remember that the safety distance is 20 metres! The user must always ensure he has full visibility over the work area.
- When driving off-road. Avoid loading on slopes, although if you are forced to do so, take great care. If the trailer is on a sideways incline, it can tip over if the trailer steering is steered in the "wrong" direction. If you are loading on sloping terrain, take on smaller loads than normal.
- Do not overload the trailer. Logs can weigh different amounts, even though they may look very similar.
- The support legs must be fully raised before moving the trailer. Before using the machines, you must ensure that the support legs have stabilised the trailer. The support legs must be used to stop the trailer from overturning. If the bearing capacity for the support legs is poor, place a slab or equivalent under the support legs to safeguard the bearing capacity.
- Use the tractor's parking brake when loading. In certain cases, it may be necessary to have chocks of some form in front of the wheels. The trailer's hydraulic drum/disc brakes are only intended to be used when travelling, not as parking brakes.

NOTE! FARMA trailers can be equipped as an option with disc brakes on all models. Only acting as assisting brakes for forest use.

2.4 Location of the decals on the trailer

The trailer is equipped with a range of decals relating both to safety and information. Check that all the signs are in the correct positions.

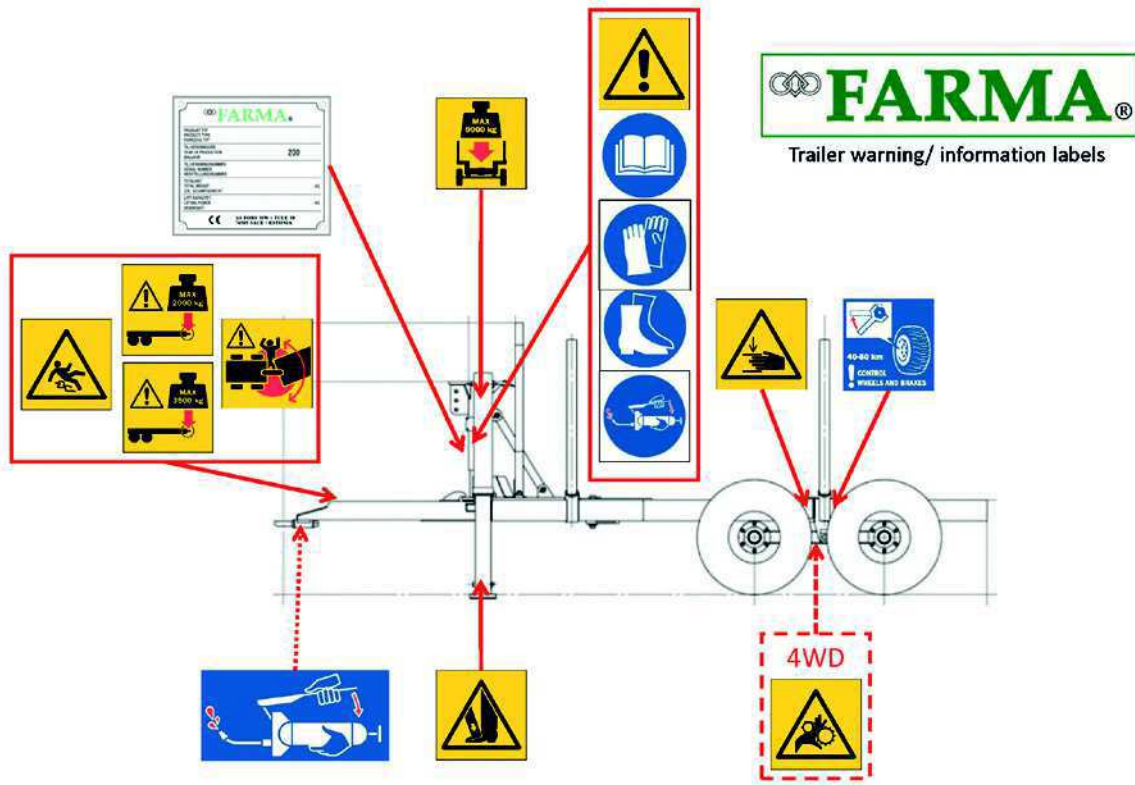

2.5 Presentation of decals



Risk of slipping

There is a risk of slipping as the surfaces of the trailer can be slippery due to precipitation in combination with pre-existing oil and/or clay on the surface. The ground around the trailer can also become slippery, as the tyres can tear up the surface and expose clay and soil.



Max. pressure on towing eyelet

Ensure that you do not load so much that the pressure on the towing eyelet exceeds the permitted laws and regulations. The pressure is largely determined by the way the load is distributed on the container bridge, and it is the user's responsibility to ensure that this is not exceeded.



Hazardous area

Standing between the trailer and the towing vehicle when the trailer is being driven, moved with frame steering or when other functions are activated between trailer and towing vehicle, can be potentially fatal. As the driver, you must always ensure that the area around the machine is free of people.

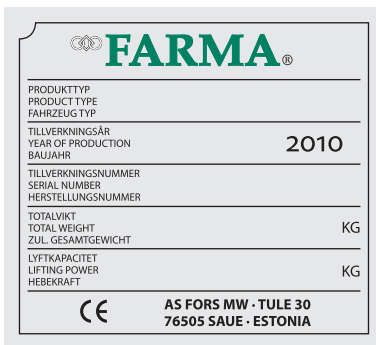

FARMA ID plate

Each trailer that is delivered is supplied with a ID plate. Ensure that the trailer has this plate and check the data contained on the plate.



Lubrication

This decal is used to show the importance of regular lubrication of the trailer.

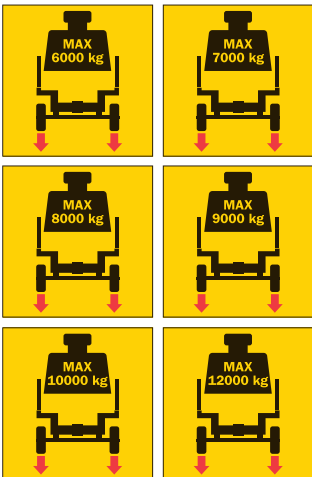

Max. load

It is absolutely prohibited to load more than the amount your model is intended to handle. This can result in danger to you and your surroundings. For information about your model, see the technical data and the designation plate on your FARMA.



Warning regarding risk of clamping injuries when folding out the support legs

Ensure that the area around the support legs is free and that no people or materials can be injured or damaged when the legs are folded down. If the bearing capacity is poor, an additional support surface must be provided with the aid of e.g. support plates, timber or a corresponding material, safeguarding the stability of the trailer with support legs folded out. Stop loading immediately if the bearing capacity is insufficient.



Warning triangle and instruction manual decal

The trailer is supplied with a warning triangle alongside the instruction manual decal in order to clarify the requirement for the user to read the entire instruction manual carefully before starting to use the trailer. Ignoring this can entail a danger to life.



Decal for the use of safety equipment

These decals challenge the user to employ appropriate safety equipment in order to avoid injury when using the trailer.

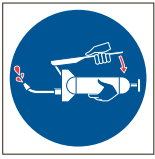
**Lubrication**

This decal is used to show the importance of regular lubrication of the trailer.

**Risk of clamping injuries**

There is a risk of clamping or crushing injuries during work and maintenance.

**Tyre inspection**

The tyres must be tightened and the brakes checked regularly at a minimum interval of 40-50 kilometres.

**Risk of clamping injuries with 4WD**

There is a risk of clamping or crushing injuries during work and maintenance. If your model is equipped with 4WD, this decal will be present on your trailer.

3 INSTRUCTIONS FOR SAFE USE

3.1 Technical description

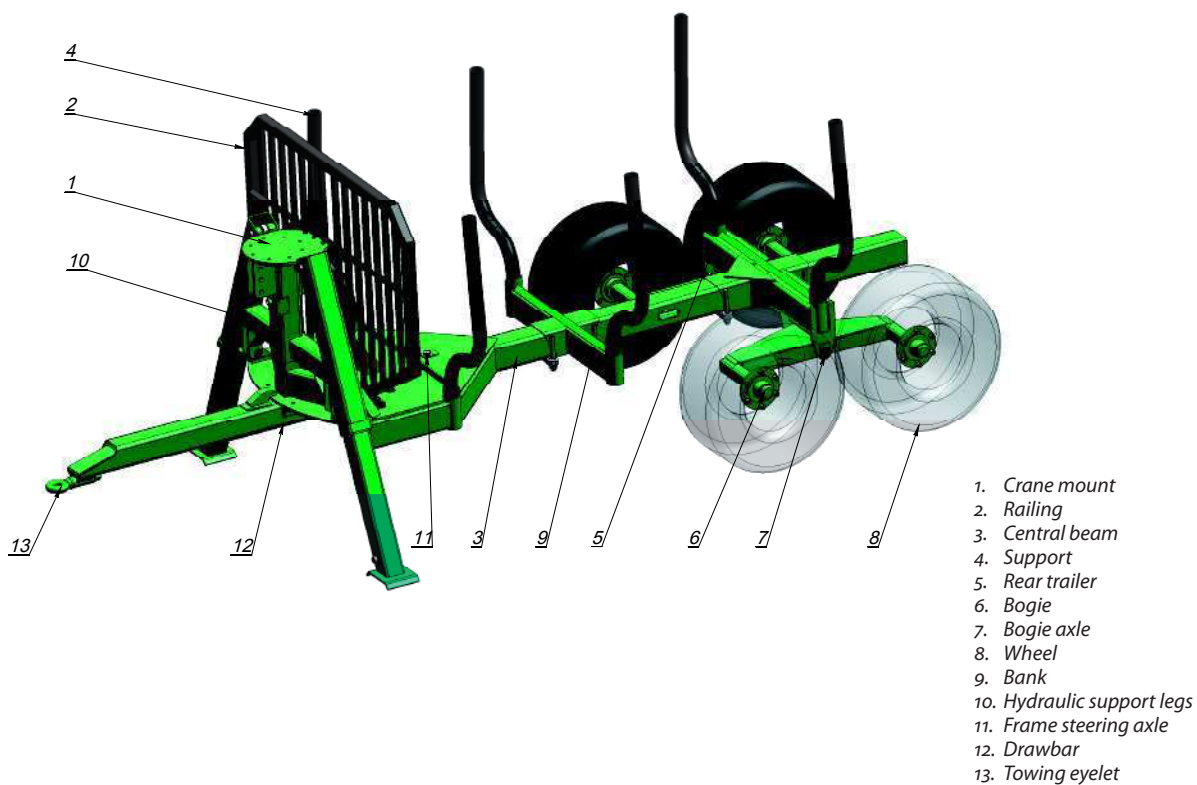

3.2 Loading the towing eyelet

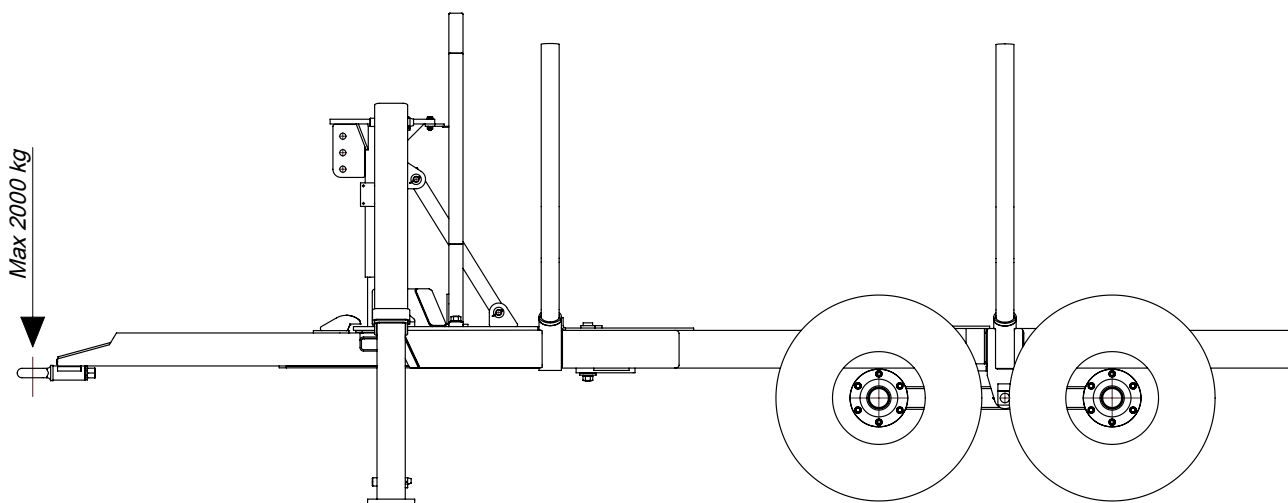

The vertical load on the towing eyelet may not exceed the load for which the towing vehicle's towing device is approved, or a maximum of 2,000 kg. The load on the towing eyelet is governed primarily by four factors:

.

- The size of the load
- The density/weight of the material which is dependent on moisture content, tree species, etc.
- The overhang behind the trailer
- The location of any movable bogie on the frame.

It is the responsibility of the user to ensure that the permitted weight on the towing eyelet is not exceeded, by loading correctly and taking the above factors into consideration. Never load more than the amount for which the trailer is intended. Load and drive the trailer with consideration for weather conditions, road surface and the driver's experience.

3.3 Tightening torques

	Thread	Offset - + 30 mm/over	Quality (St37) Offset - + 15 mm/under	Quality (St52) Offset - + 15 mm/under
With conical collared nuts and uncollared nuts.			Bolt. 8.8	Bolt. 10.9
			Nm.	
	M18 x 1.5	310	330	460
	M20 x 1.5	-	490	630
	M22 x 1.5	-	630	740
With flat collared nut with spring washer	M18 x 1.5	210	270	360
	M20 x 1.5	-	360	450
	M22 x 1.5	-	460	550
With flat nut with flat washer	M18 x 1.5		260	360
	M20 x 1.5		350	500
	M22 x 1.5		450	650
Screw-mounted disc for wheel rim with adjustable offset	Thread		Flat disc	
			Bolt. 8.8	
	M18 x 1.5		260-330	

3.4 Air pressure in the tyres

Tyre dimension	Max. air pressure (Bar)	Max. load (kg)
11.5/80 x 15.3, 10pr	3,4	1950
400/60 x 15.5, 14pr	3,6	2900
500/50 x 17, 18pr	4,4	4120
500/50 x 17, 14pr	3,5	3250
500/55 x 17 ELS	3,1	4020

4 THINGS TO CONSIDER BEFORE AND WHEN DRIVING

4.1 Connecting the trailer

During loading and transport on public roads, adhere to the applicable traffic legislation.

Note: When connecting and disconnecting the trailer, bear in mind the risk of clamping injuries, the risk of slipping, the tipping risk and the risk of hydraulic high-pressure jets and hot oil. Ensure that neither the hydraulic pump nor the power take-off is connected.

- Check that the towing eyelet's lock is undamaged and properly tightened.
- Connect the trailer's towing eyelet to the towing vehicle's tow hook. Ensure that the towing device is properly locked.
- Check the condition of the tyres and their air pressure.
- Check that the wheel nuts are tightened.
- Always check that the quick couplings are clean and that they lock properly.

Trailer steering

- Connect both the hydraulic cylinders for the trailer steering's cylinders to the tractor's double-action hydraulic outlet. Ensure that the quick couplings are clean and that they lock properly.

Hydraulic disc/drum brakes

- Connect the hydraulic hose to the tractor's brake valve or single-action hydraulic outlet.

Note: When connecting to an outlet other than the brake valve, brake pressure can be built up when working with the crane due to internal leakage in the tractor's hydraulic system. Always ensure that the brakes are not applied before departing.

Travel lights

- Connect the light connector to the tractor's trailer outlet (12 V).

4.2 Disconnecting the trailer



The oil can be very hot! Do not allow the hydraulic hoses to hang down to the ground!

- Park the trailer on a flat, stable surface. Position a stable support under the drawbar and place chocks by the trailer's wheels to prevent it from rolling away.
- Switch off the tractor's hydraulic pump and power take-off. Release the remaining hydraulic pressure.

- Disconnect the hydraulic hoses. Start with the pressure line first, followed by the return lines and finally any electrical contacts. Ensure that protective plugs are installed in the hoses.
- Finish by disconnecting the trailer's towing eyelet from the towing vehicle's tow hook.

4.3 Test driving the trailer

Note: The support legs must be fully raised before moving the trailer.

Note: Avoid loading on slopes, although if you are forced to do so, take great care. If you are loading on sloping terrain, take on smaller loads than normal.

- Before test driving, ensure that the load is anchored.
- Undo the transport lock for the trailer steering.
- Start the tractor's hydraulic pump or power take-off.
- Carefully check the trailer steering's movements. There may be air in the system causing the movements to be jerky.
- Ensure that no hoses are stretched too much or trapped against sharp edges.
- Check the movements of the support legs.
- In the event of any leaks, tighten the leaking connections.
- Check that the lights work.
- Check the brakes.

4.4 Operating instructions

Note: If damage should occur during use, the work must be halted immediately and the fault pinpointed and rectified before starting to use the trailer again.

Note: The trailer's hydraulic brakes are only intended to be used when travelling, not as parking brakes, unless otherwise indicated.

Sideways inclines

- There is always a danger when operating on sloping terrain. When driving on a sideways incline, the risk of overturning can be reduced by driving the trailer higher up than the tractor using the trailer steering.

Loading/Unloading

- Stability can be increased during loading and unloading by steering the trailer steering in the opposite direction from the direction in which the crane is working.
- Even if the support legs have been lowered to the ground, the risk of overturning is always greater when the trailer is empty or only has a small load. You must therefore give particular attention to stability.

Narrow passages

- The trailer can be tracked in narrow passages by steering the trailer using the frame steering. Note that there is some risk of overturning. Always operate with gentle lever movements.

Weight distribution

- The weight distribution of your machinery is extremely important. In order to achieve the optimum weight distribution, the rear trailer can be adjusted to the position where the timber's centre of gravity is directly above the front bogie wheel. Check that the bolted joints are properly tightened following adjustment.

Driving off-road

- On steep terrain, drive straight up or down slopes in order to reduce the risk of tipping. Never drive across slopes that are so steep that you cannot drive up them.
- When driving up a slope, the risk of the towing vehicle rearing up increases when the machinery's centre of gravity has been moved backwards. In such situations, it is important to consider having e.g. a tractor-mounted crane at the front and to use extra weights if necessary.
- You must be particularly careful when leaning to the side. It only needs a small change for the towing vehicle or the trailer to overturn.
- The trailer's centre of gravity is higher than the towing vehicle when you are driving with a load. This means that the towing vehicle may be able to pass through a critical passage that the loaded trailer cannot manage.
- Bear in mind that it is more difficult to control a large, heavy load than a smaller, lighter one. You should therefore adapt the load to the size of the towing vehicle and the terrain conditions. Always adapt your driving to your level of experience.

Note: If the tractor tips over, hold onto the steering wheel firmly and do not jump out! The cab is your best protection!

Working in extreme situations

The recommended ambient working temperature for this machine is -30°C to $+40^{\circ}\text{C}$. Note that when working in low or high temperatures, the level of wear and stress on seals and hoses increases. The durability of the steel is also impaired, and cracks can occur.

When working under extreme conditions, work with smaller loads than normal in order to prevent damage. When working in cold conditions, always allow the hydraulic fluid to circulate freely for a number of minutes. Then operate each function a number of times to allow seals and hoses to soften up before applying full pressure. During extremely warm periods, take care with the temperature of the oil. Temperatures of above 80°C destroy the oil's properties and damage seals and hoses.

5 MAINTENANCE/SERVICE

To keep your trailer in good condition, you need to carry out regular maintenance. Regular and correctly performed maintenance are a precondition in order for the guarantee to be valid. During all service or repair work the trailer must be unloaded. When carrying out repairs or maintenance, take care when climbing onto the trailer.

Note: Only genuine parts may be used during repair and maintenance.

Lubrication

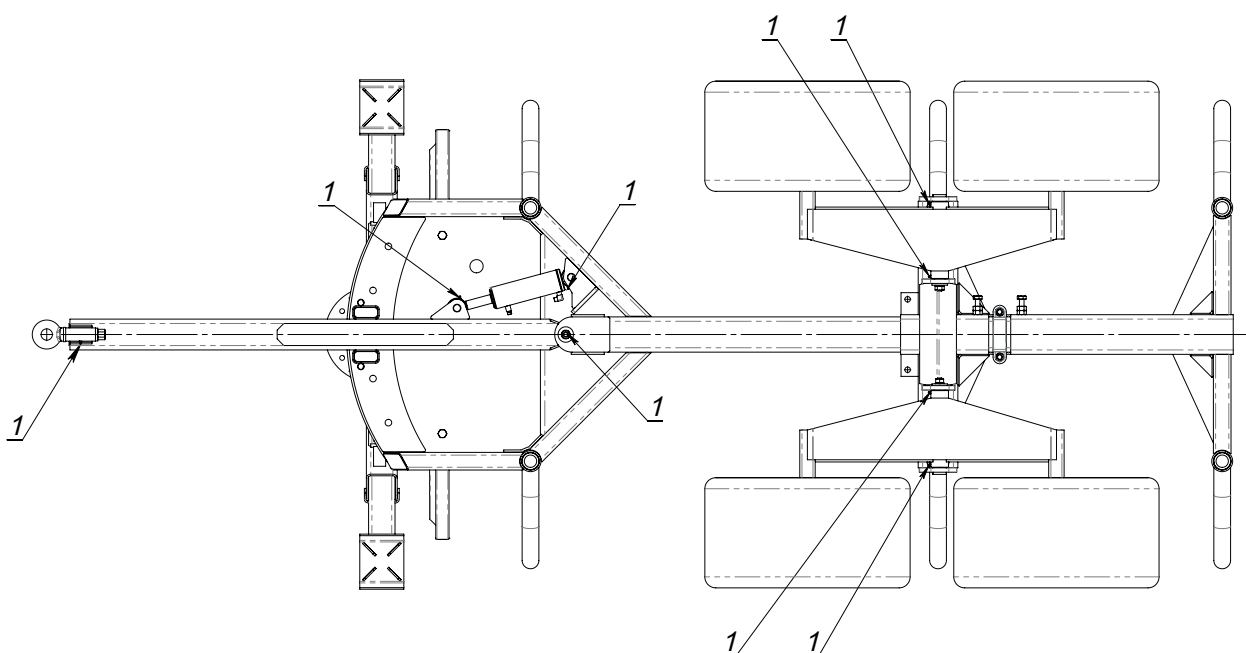

Lubrication schedule for all trailers up to the 12 tonne model.

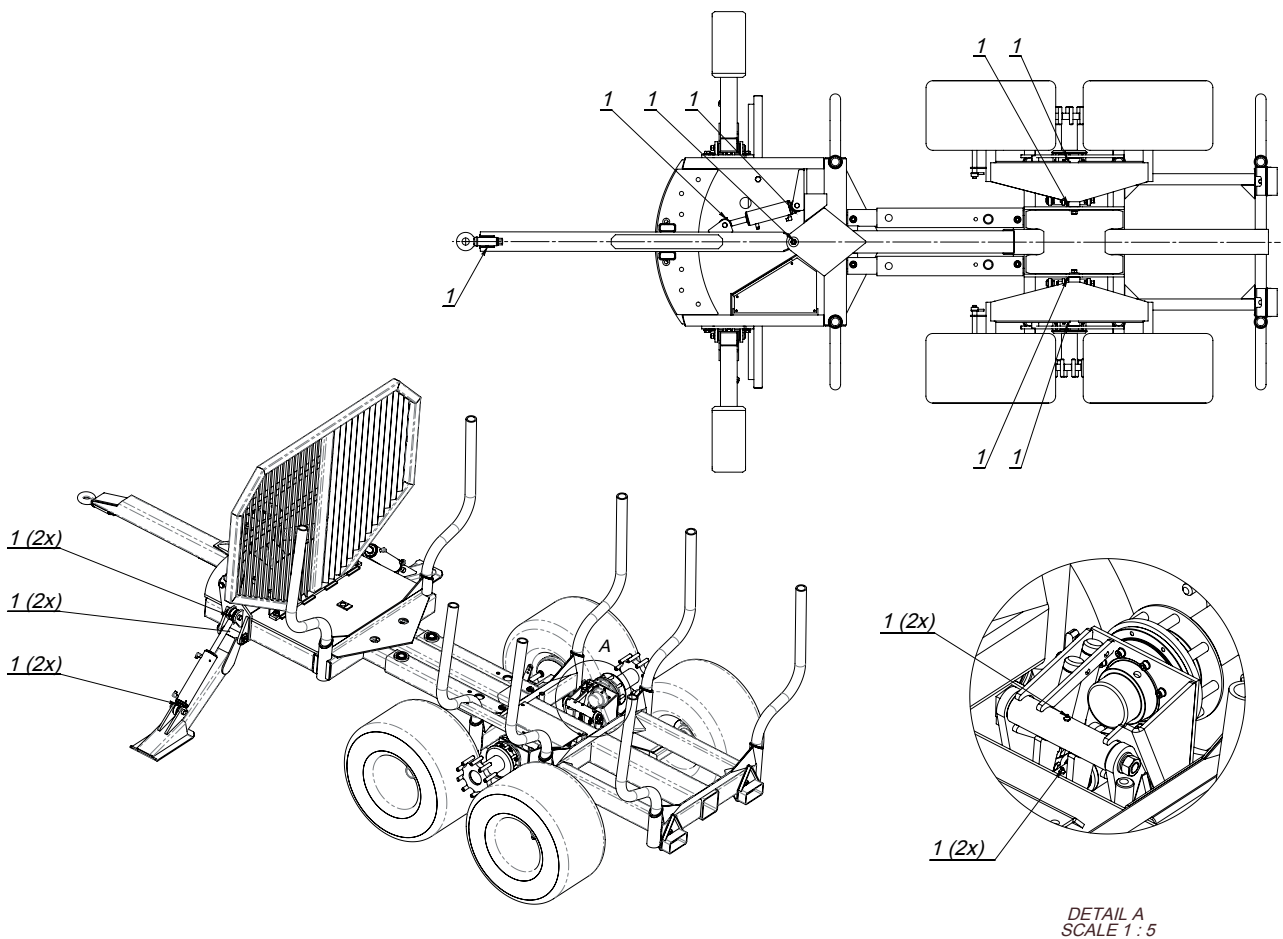

Lubrication schedule for T 12 4 WD.

- Follow the lubrication schedule during lubrication.
- Also clean the grease nipple before lubrication.

Cleaning

- When cleaning, first perform a rough clean using just water, although avoid using high-pressure sprays on electrical components.
- Use an environmentally friendly detergent. Allow it to work for the specified time. Rinse off with hot water.
- Always lubricate the trailer after cleaning.

The hydraulic system



Ensure that the hydraulic system is not under pressure before commencing service or repair work on the system.



Never work under a load that is dependent on the hydraulic system. Use a support that prevents the load from falling.

- Never repair a leaking hydraulic system when it is under pressure.
- Never use your hands to search for leaks in the hydraulic system. An oil jet can easily penetrate the skin, resulting in serious injuries. As the oil is hot, both burn injuries and fire can occur.
- Avoid getting oil in your eyes by wearing protective goggles.

Towing eyelet

Note: Welding is not permitted on the towing eyelet!

Check the towing eyelet for wear. The wear limit for a towing eyelet with 30 mm of material is 20%. If the towing eyelet has sustained damage, immediate replacement is mandatory. The towing eyelet must be checked for defects whenever the trailer is to be used.

Note: It is the user's responsibility to check the towing eyelet. The towing eyelet is certified in accordance with ISO 5692.

5.2 Air pressure

For information, see point 3.4

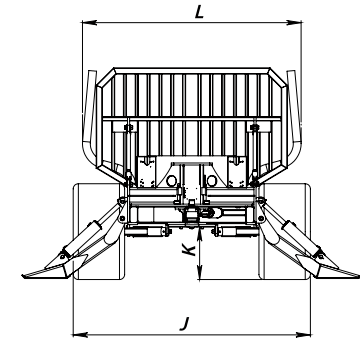
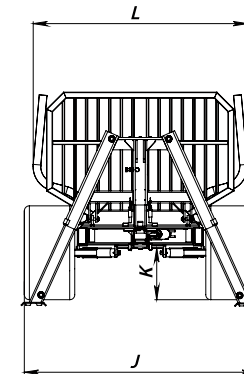
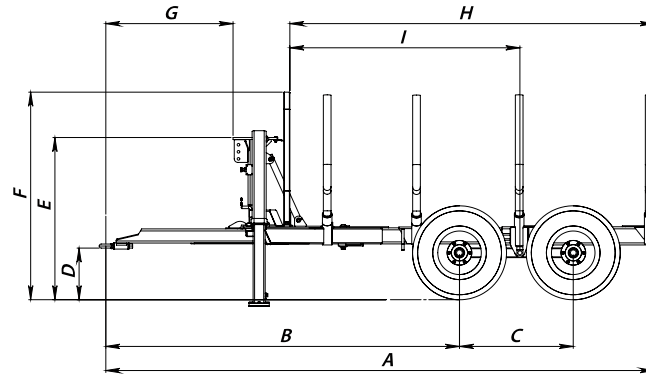

FARMA® Original trailers

* Adjustable dimensions.

Model	A mm	B mm	C mm	D mm	E mm	F mm	G mm	H mm	I mm	J mm	K Ground clearance, mm	L mm	Gross weight, kg	Load area, m ²	Wheel dimensions	Standard trailer weight, kg	Steering angle frame steering, degrees
T6	4 390	2 800*	945	415	1 240	1 630	1 155	2 825	1 745*	1 800	475	1 755	6 000	1.4	11,5/80-15.3	720	X
T7	5 410	3 860*	990	525	1 560	2 040	1 310	3 565	2 550*	1 935	505	1 870	7 000	1.95	11,5/80-15.3	1 110	40
T7S	5 410	3 860*	990	535	1 570	2 050	1 310	3 565	2 550*	2 070	515	1 870	7 000	1.95	400/60-15.5	1 180	40
T8	5 410	3 860*	990	535	1 570	2 050	1 310	3 565	2 550*	2 070	515	1 870	8 000	1.95	400/60-15.5	1 310	40
T9	5 360	3 790*	990	520	1 615	2 065	1 260	3 535	2 500*	2 135	530	1 970	9 000	2.1	400/60-15.5	1 640	48
T9 4WD	5 400	3 495-3 945*	990	525	1 620	2 070	1 260	3 570	2 205-2 655*	2 135	505	1 970	9 000	2.1	400/60-15.5	2 520	48
T10	5 365-6 255*	3 430*	1 130	505	1 600	2 050	1 260	3 540*	2 205-3 095*	2 300	505	2 125	10 000	2.2	500/50-17	1 720	48
T10 4WD	5 400	3 495-3 945*	990	530	1 625	2 075	1 260	3 570	2 205-2 655*	2 325	510	2 125	10 000	2.2	19/45-17	2 660	48

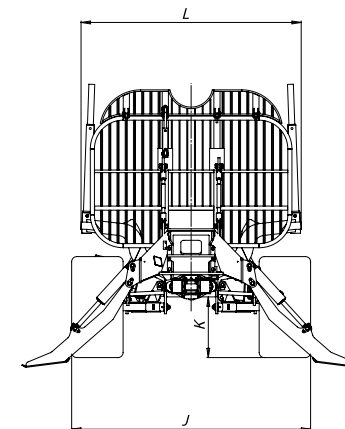
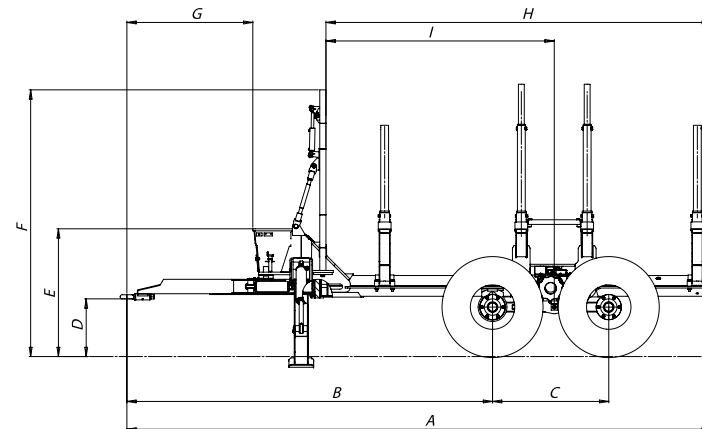

We reserve the right to alter specifications without prior notice. Figures for the measurements are only of illustrative purpose.

FARMA® Generation 2 trailers

* Adjustable dimensions.

Model	A mm	B mm	C mm	D mm	E mm	F mm	G mm	H mm	I mm	J mm	K Ground clearance, mm	L mm	Gross weight, kg	Load area, m ²	Wheel dimensions	Standard trailer weight, kg	Steering angle frame steering, degrees
T10 G2	5 680	3 655-4 110*	1 130	515	1 195	2 290	1 225	3 745	2 320-2 775*	2 325	525	2 140	10 000	2.3	500/50-17	1 935	52
T12 G2	5 935-6 610*	3 655-4 110*	1 130	545	1 225	2 320	1 225	4 000-4 675*	2 320-2 775*	2 285	555	2 140	12 000	2.3	500/45-22.5 Trac	2 025	52
T14 4WD G2	5 680	3 500-3 955*	1 130	570	1 250	2 600	1 225	3 745	2 165-2 620*	2 325	580	2 140	14 000	2.8	500/55-17 Trac	2 500	52
T16 4WD G2	5 925-6 655*	3 985-4 715*	1 285	440	1 365	2 675	1 400	3 655-4 385*	2 395-3 125*	2 570	600	2 500	16 000	3.2	600/50-22.5 Trac	4 000	52