



FARMA®

Cranes

EN_V2.0-2015

Original instruction

INSTRUCTION MANUAL

CONTENTS

1	INTRODUCTION	3
1.1	MAIN PARTS OF BOOM SYSTEM.....	4
1.2	4 TYPES OF FARMA CRANES	4
2	SAFETY REGULATIONS	5
2.2	GENERAL SAFETY REGULATIONS	5
2.3	LOCATION OF DECALS ON THE CRANE	6
2.4	PRESENTATION OF DECALS	7
2.5	INSTRUCTIONS FOR SAFE USE.....	9
3	SERVICE/MAINTENANCE.....	14
3.1	GENERAL INFORMATION	14
3.2	FOR YOUR SAFETY DURING SERVICE/MAINTENANCE	14
3.3	DAILY INSPECTION.....	15
3.4	LUBRICATION SCHEDULE	16
3.5	TIGHTENING TORQUES.....	20
3.6	STORAGE	20
4	OPERATING THE CRANE	21
4.1	ASSEMBLING THE CRANE	21
4.2	DESCRIPTION OF FUNCTIONS	21
4.3	INSTALLING THE CRANE ON A TRACTOR	22
4.4	DISMANTLING CRANE WITH THREE POINT LINKAGE.....	23
4.5	INSTALLING THE CRANE ON A TRAILER	24
4.6	WORKING WITH THE CRANE.....	25
4.7	TEST OPERATING THE CRANE	27
4.8	LEARNING THE LEVER MOVEMENTS.....	27
4.9	CONTROL LEVER PANEL MOVEMENTS	28
4.10	CONTROL LEVER PANEL MOVEMENTS FOR EACH CONTROL.....	29



1 INTRODUCTION

This instruction manual is intended for FARMA cranes, and contains information for safe use. This crane is only intended to be used from the tractor. FARMA cranes are intended for self-employed work in the fields of agriculture and forestry. The product is particularly useful for handling round timber, fodder, fertiliser, sand, loose fertiliser, large sacks, etc. With forestry, the cranes are intended for automatic timber transportation, as well as for basic professional work when the model's permitted lifting torque permits. The permitted lifting forces may not be exceeded under any circumstances. For information about permitted load, see the movement pattern on the trailer and in the instruction manual.

Even if you have experience of this type of product, we recommend that you read our instructions carefully in order to familiarise yourself with the product. The instructions contain information that is vital for safety and efficiency, as well as to ensure the validity of the factory guarantee. When the product you have purchased is delivered, check that it has not sustained any delivery or transport damage. If there should be any such damage, or if any parts are missing, contact your dealer immediately.

It is the responsibility of the user to inform himself regarding the use of the product and to follow the instructions carefully. It is also the responsibility of the user to ensure that attachments and connections to the vehicle are designed and adapted in such a way that they satisfy the crane's technical data by a clear margin. It is the responsibility of the user, for example when installing a loose crane on equipment other than a FARMA trailer, to ensure that the vehicle has the necessary capacity to cope with the lifting and slewing torques that the crane is designed to handle.

Fors MW reserves the right to make changes to equipment and maintenance instructions and to revise its data without prior notice.

Fors MW conforms to ISO 7010 for safety marking in accordance with the EC directive 2006/42/EC.

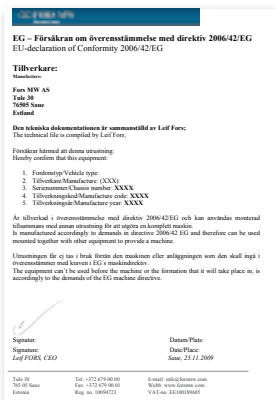

Manufacturer:

AS FORS MW
 TULE 30
 765 05 SAUE
 Tel: + 372 679 00 00
 www.forsmw.com

Dealer:

1.1 Main parts of boom system

Item No.	Description
1	Base
2	Slewing mechanism
3	Column
4	Main boom
5	Main boom cylinder
6	Boom extension, hydraulic

Item No.	Description
7	Outerboom
8	Outerboom cylinder
9	Boom extension 1
10	Boom extension 1 cylinder
11	Boom extension 2

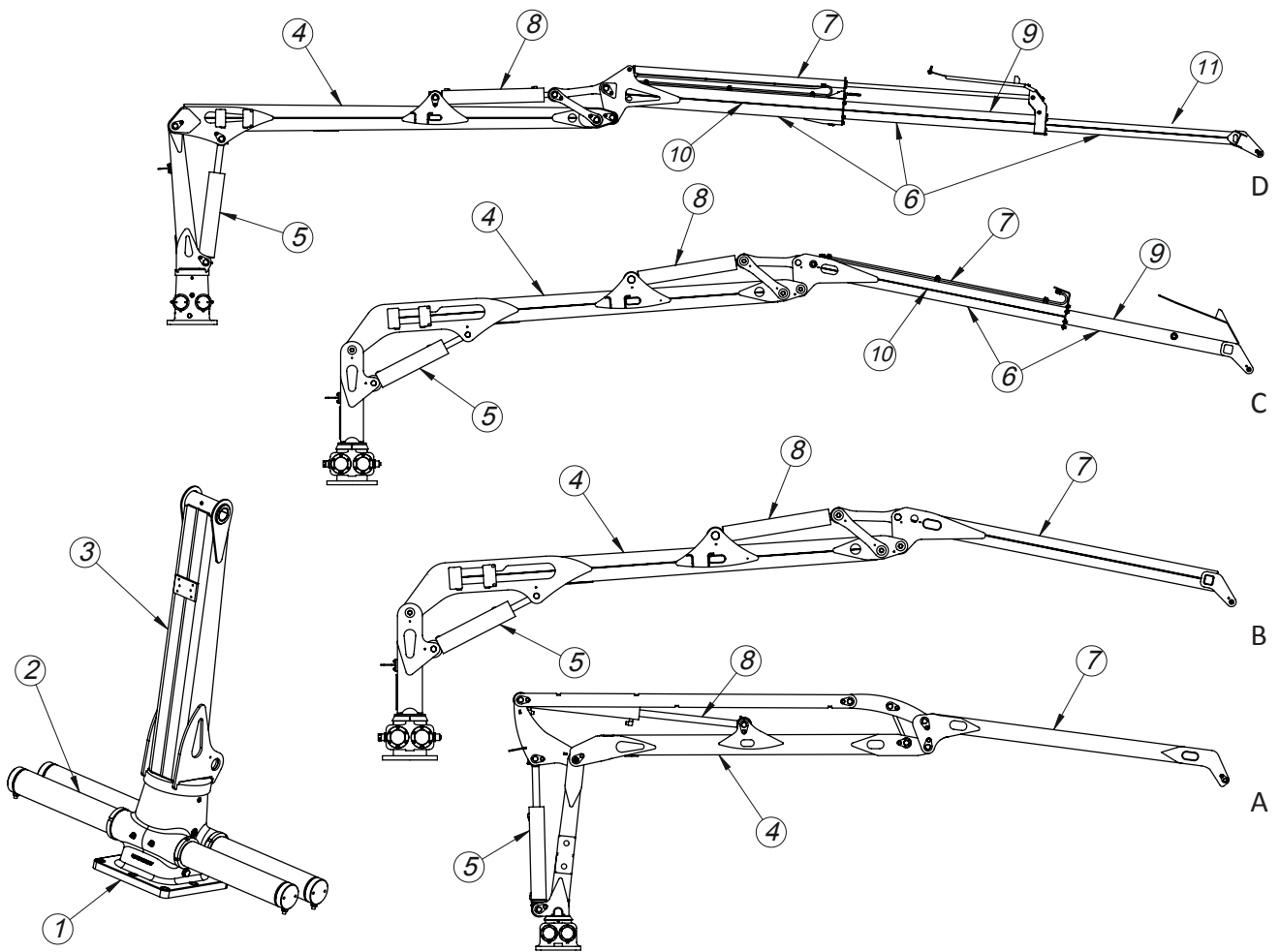

1.2 4 types of FARMA Cranes

Item	Description	MODEL
A	Crane with parallel main boom, no boom extension	C4,0P
B	Crane without boom extension	C3,8/C4,6/C5,1/C5,3
C	Crane with telescopic boom extension	C4,2/C6,3/C7,0
D	Crane with double telescopic boom extension	C8,5

2 SAFETY REGULATIONS

2.1 Description of the use of warning symbols

In the instruction manual, we distinguish between the terms Warning and Note. These markings are used to draw the attention of readers to the fact that this is an area that is of particular importance.

Warning! = A very important item of safety information is supplied with this warning symbol. Warnings refer to the risk of injury or death for people, as well as the risk of serious damage to the equipment.

Note: = The Note symbol indicates that the product, process or environment may sustain damage, as well as indicating the risk of minor injuries.

2.2 General safety regulations



Carefully read through the instruction manual before using the crane. Important data relating to your particular crane can be found in the crane's technical data. Incorrect usage can result in injuries to you and damage to the crane.

Operating a crane requires a high level of expertise, as well as knowledge about the machine you are using. It is important for you to acquire knowledge and to train with regard to the crane's behaviour. Practice the movement pattern and always work with smaller loads until you are completely familiar with the crane. Take care to ensure that nobody is within the safety zone (20 m).

FARMA cranes are intended for normal use within agriculture and forestry, and may only be used by individuals who possess knowledge about the handling of agricultural machinery.



- This crane is only intended to be used and operated from the tractor's driver's seat.
- Before you connect the crane to the tractor's hydraulic system, you must have read through the tractor's instruction manual so that you know how the crane is to be connected to the tractor.
- Familiarise yourself with the crane and its functions.
- Take extreme care when connecting the crane to and disconnecting it from the tractor or trailer.
- Ensure that nobody is within the crane's risk zone while work is in progress. The user must have full visual control over the working area.

- Do not insert your hand or any other part of your body into the machine, the wiring system or under the load while work is in progress. Do not risk becoming trapped between the crane's parts or between the tractor and the trailer.
- Don't forget to raise the support legs before moving the equipment.
- Always use the tractor's parking brake when loading.
- Never overload the trailer or hook.
- Never leave the boom in the raised position unless you are in control of the crane.
- Never use the crane for pulling/pushing or striking.
- Take particular care when loading and unloading heavy materials.
- Never use the loader during transport.
- Stop working by lowering the crane and the grapple onto a firm surface, switch off the engine, engage the parking brake and remove the ignition key to prevent unauthorised usage.
- The crane is not intended for lifting people.
- Take great care when loading and unloading in the vicinity of power lines. Maintain the safety distance to live cables.
- You must not hand the crane over to an outside individual without first having ensured that this person is familiar with the operating and safety regulations.

2.3 Location of the decals on the crane

The crane is equipped with a range of decals relating both to safety and information. Check that all the signs are in the correct positions.



2.4 Presentation of decals



Warning of suspended load

This decal warns against standing under or in the vicinity of the crane when it is in operation, with or without a load. Carelessness can result in direct danger to life.



Warning of contact with electrical cable

When working in the vicinity of electrical cables, take particular care to ensure the crane does not come into contact with these cables.



Hydraulic fluid under pressure

Hot hydraulic fluid at high pressure levels can occur in the hydraulic system. Take care when connecting, and replace poor quality hoses.



Risk of clamping injuries

There is a risk of clamping or crushing injuries during work and maintenance.



Safety distance 20 metres

This decal shows the importance of taking great care when working within the crane's safety zone. Always keep a close eye on and monitor the crane's safety zone. Carelessness can result in direct danger to life.



Lubrication

This decal is used to show the importance of regular lubrication of the crane.



Warning triangle and instruction manual decal

The crane is supplied with a warning triangle alongside the instruction manual decal in order to reinforce the requirement for the user to read the entire instruction manual carefully before starting to use the crane.



Decal for the use of safety equipment

These decals challenge the user to employ appropriate safety equipment in order to avoid injury when using the crane.



Lubrication

This decal is used to show the importance of regular lubrication of the crane.

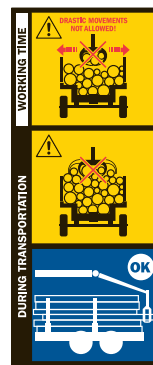

Handling and positioning of crane

This decal shows how the crane should be handled and positioned during transport and operation.

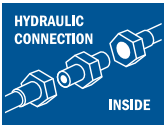

Hydraulic connection

Marking the location of a hydraulic connection. Take care during repair work, as hot hydraulic fluid can easily penetrate the skin.



Filling oil in the crane

On delivery from the factory, the crane is not supplied with oil. Oil should have been filled by the dealer prior to delivery to the customer. Check to ensure that this has happened.

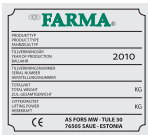

FARMA designation plate for crane

Each crane that is delivered is supplied with a designation plate. Ensure that the crane has this plate and check the data contained on the plate.

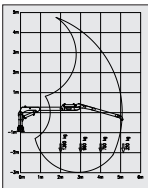

Movement pattern

Each FARMA crane is supplied with the crane's movement pattern. Ensure that the crane has this plate and check the data contained on the plate.



Warning regarding remotely started machine components

If the crane is equipped with a winch and/or radio control of crane functions, these can be started without anybody being in contact with the crane. Ensure that the area around the crane and the winch is free before starting this function, and that nobody is within the risk zone.

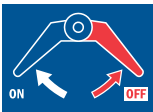

Manual switch for winch

If the crane is equipped with a winch, there can be a manual switch for activating the winch function. Turn the handle as indicated on the plate in order to engage or disengage the winch.

2.5 Instructions for safe use

2.5.1 Introduction



It is prohibited for unauthorised parties to be within the crane's risk zone, which is 20 m.



If the hydraulic system's overload protection is incorrectly affected or the system's functions are otherwise altered, safety cannot be guaranteed under any circumstances.

- Always check that there are no unauthorised persons within the risk zone.
- Never stand or walk under suspended loads.
- Ensure that the tractor and trailer are always standing on firm ground so that there is no risk of overturning. When loading, use the support legs to prevent the lumber trailer from tipping.
- Always maintain a visual check on the work area.
- Do not work under conditions where there could be a risk of clamping injuries or some other injury.
- Only use grapples that are correctly dimensioned for the work task.



Always pay attention when working close to electrical cables. Maintain a safe distance. Bear in mind the risk of unforeseen movements. If the crane should come into contact with a power line for any reason:

- Warn people in the vicinity of the crane not to touch the machine.
- Do not touch any metal parts.
- Remove the arm system from live cables.

2.5.2 Instructions in the event of emergency stop

2.5.2.1 Risk of overturning



When there is a risk of overturning, immediately lower the lifting boom by moving the control lever to the lowering position.

- Keep hold of the lever until the load is on the ground. Do not interrupt the lowering movement, as the risk of overturning will increase if the load should suddenly stop.
- Never use the outer boom for lowering the load when there is a risk of overturning, as this could result in the load ending up in the cab.
- If the tractor overturns, follow the instructions found in the tractor's cab. Do not jump out of the cab. There is a risk that you might end up under the falling load or under the overturning tractor or crane.

Note: Even if the supporting legs have been lowered to the ground, the risk of overturning is always greater when the trailer is empty or only has a small load. You must therefore take particular care as regards stability at such times.

2.5.2.2 Hose ruptures



- In the event of a loss of pressure in the hydraulic fluid or in the event of a rupture in the hydraulic hoses or pipes running between the controls and the crane, you must switch off the tractor's engine and lower the load to the ground immediately. Disconnect the hydraulic flow. Repair the rupture. Take care to clean up any oil that has run down to the ground. Hand in waste to an appropriate waste management facility.
- If the rupture is in the main pressure hose from the tractor to the controls, you must stop the oil flow by disconnecting the lever control for the tractor's hydraulic outlet or by switching off the tractor's engine with the stop button. Also take care to clean up any oil that has run down to the ground.

2.5.3 Driving on public roads

Follow these instructions to avoid the risk of accidents. The manufacturer and dealer are not responsible for any damage in the event of failure to comply with these instructions.

Transport position

- When the trailer is not loaded, park the crane's arm system as low as possible on the trailer. Ensure that the grapple and rotator are securely locked to the trailer so that the crane cannot swing out sideways during transport. Do not drive off without placing the crane as low as possible in its transport position.
- Ensure that none of the additional equipment connected to the crane can cause accidents during transport.

Control is important

- You must always maintain control of the unit in all situations.
- Always check that the LGV sign and reflective signs are in the correct locations. Check that the lights on the trailer are working and that the tyre pressure is correct.
- The permitted axle and total weights, as well as the transport dimensions, must never be exceeded.
- Before driving, check that nobody is in the vicinity of the machine and that your visibility is unrestricted.

Note:

- Observe the specified safety distance to electrical cables when you are in the vicinity of such cables.
- Bear in mind the height of the machine when driving under flyovers.

Rules are there to be followed



It is important for you to adapt your speed to the driving situation. Drive carefully on sideways inclines. The same applies on slopes. Risk of overturning.

- Traffic rules are there to be followed. Comply with the applicable legislation.
- A tractor with a trailer has a longer braking distance than other vehicles. Be aware of the risk of skidding, and look out for irregularities in the road surface.

Note: Firmly secure the load and other loose goods.

2.5.4 Hydraulic system

Note: Always read through the relevant safety instructions when connecting and using the crane's hydraulics. All hydraulic hoses should be considered to be pressurised.

For disruption-free operation, oil must be changed and filters replaced at the specified intervals. When replacing hydraulic components, this should be carried out in such a way that no dirt enters the system. Use a lint-free cloth or rag when cleaning.

Note: It is prohibited to release oil onto the ground or into watercourses. Never mix oils of different types or makes in the system.



The crane's hydraulic valves are supplied with both main pressure limiters and choke valves to prevent the crane from being overloaded. No modifications of any type may be carried out.

- Do not start the tractor without having disconnected the hydraulic pressure to the crane.
- Support the crane during maintenance work to ensure that no parts are dependent on the hydraulic cylinder.
- Pinpoint the fault before carrying out repair work, so that you do not open the hydraulic system unnecessarily.
- If possible, engage trained service personnel for any work on the machine's hydraulic functions.
- The crane's hydraulic valves are supplied with both main pressure limiters and choke valves to prevent the crane from being overloaded. Modifications may not be carried out under any circumstances.
- The crane's hydraulic hoses and pipes must always be kept in good condition. Replace the relevant components in the event of any defects. Defects in hoses, for example, can result in a high-pressure jet of oil that can penetrate skin on contact and cause a serious infection. If this occurs, consult a doctor immediately.

Note: When the hydraulic system is brought back into use following repair work, be extremely carefully. Air in the system can result in unforeseen crane movements. You should therefore bleed the system by operating all the cylinders to their limit positions a few times.

Note: When using the hydraulic functions, you should use them gently. Do not operate them at full speed from one position to the next. This can cause damage to hydraulic seals and other parts.

2.5.5 Replacing hydraulic components

Always use genuine parts when it comes to hoses, seals, bolts, etc. Using genuine parts guarantees usage that is as fault-free as possible.

REPLACING SEALS

If a cylinder seal is damaged, replace all the seals in the cylinder.

Take care when replacing seals to ensure you do not damage them during installation.

1. Once the old seals have been removed, carefully clean the cylinder and piston rod before installing the new seals.
2. Lubricate the new seals with hydraulic fluid.
3. If possible, engage the specified service personnel for any work on hydraulic functions.

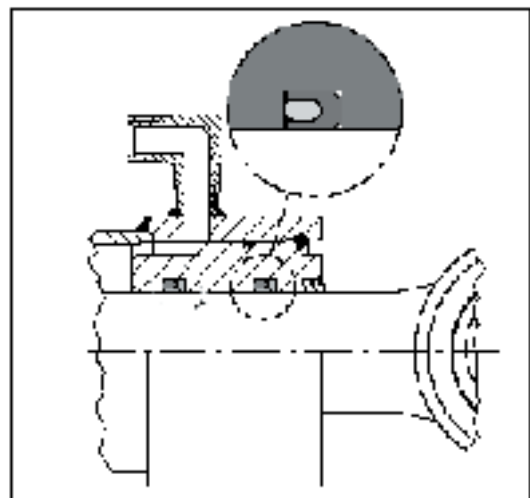

2.5.6 Handling oil/grease



Carefully read through the warning information on the oil and grease products you are using, and follow their instructions accurately.

- Avoid skin contact with oil and grease during service work.
- Wear the correct protective clothing.
- Never clean your hands with lubricating oil or grease. This can damage your skin.
- If oil or grease causes changes to your skin, seek medical attention immediately.
- The law demands that all waste oil be dealt with and disposed of at the correct place during service and maintenance.

2.5.7 Repair welding



If repairs or modifications require welding work, you must first contact your dealer, who will provide you with the necessary welding instructions. Incorrect welding or ignorance during welding can result in sudden breaks in the structure.

2.5.8 Working in extreme conditions

The recommended ambient working temperature for this machine is -30°C to $+40^{\circ}\text{C}$. Note that when working in low or high temperatures, the level of wear and stress on seals and hoses increases. The durability of the steel is also impaired, and cracks can occur.

When working under extreme conditions, work with smaller loads than normal in order to prevent damage. When working in cold conditions, always allow the hydraulic fluid to circulate freely for a number of minutes. Then operate each function a number of times to allow seals and hoses to soften up before applying full pressure. During extremely warm periods, take care with the temperature of the oil. Temperatures of above 80°C destroy the oil's properties and damage seals and hoses.

3 SERVICE/MAINTENANCE

3.1 General information

Service and maintenance must be carried out regularly in order to guarantee problem-free, economical use.

Note: Failure to comply with the Fors WM instruction manual invalidates all the machine's guarantees. Regular, correct maintenance is a precondition for the guarantees applying.

Note: Only genuine spare parts may be used during repair and maintenance work.

3.2 For your safety during service/maintenance

Read the instructions before starting to service the machine. Do not attempt to carry out work on or to service the machine until you are completely familiar with and understand the instructions. Read and following the instructions before each service. Adhere to the recommended service and lubrication intervals.



- Only genuine spare parts may be used during repair and maintenance work.
- Always use tools adapted to the purpose.
- Always wear protective clothing and protective goggles.
- Always switch off the tractor's engine. Switch off the tractor's engine and remove the key from the ignition.
- If it is necessary for the tractor's engine to be running during certain elements of the service, take care to keep parts of your body away from moving machine parts.
- During service work, the crane should be lowered to the ground so that no parts are dependent on the hydraulic cylinder.
- Take great care with oil that is under pressure. Oil under high pressure can easily penetrate the skin. Consult a doctor immediately in the event of an accident.
- Hot oil can cause burn injuries. Inhalation of hot oil mist can cause breath difficulties.
- Getting oil on your skin in the event of a hose explosion is not dangerous, although you should avoid contact with your eyes and nose. In the event of exposure to oil in your respiratory tract or your eyes, contact a doctor immediately.
- Store explosive and flammable liquids at a safe distance from sparks or open flames.

Note: When changing oil, collect the oil in a safe manner. Never release oil onto the ground. This is prohibited by law. Oil and grease must by law also be disposed of at an authorised location.

3.3 Daily inspections



Remember that

- It is important to inspect the equipment daily.
- If you see any defects, you must rectify them immediately.
- Worn bolts and screws can entail a risk of breakages when under load.
- If cracks are discovered in the crane, operations must be halted immediately.
- Damaged hoses must be replaced immediately.
- Check for leaks. Leaking hydraulic fluid entails a risk of accidents and can result in serious environmental damage.

Note:

- Check all bolted joints and tighten all loose bolts.
- Operate the crane's complete movement pattern to ensure that all functions are intact.
- If necessary, lubricate and check the oil level in the turntable housing.
- Avoid high-pressure washing when cleaning. First clean simply with warm water. If necessary, use an environmentally friendly detergent. Lubricate the crane after cleaning.

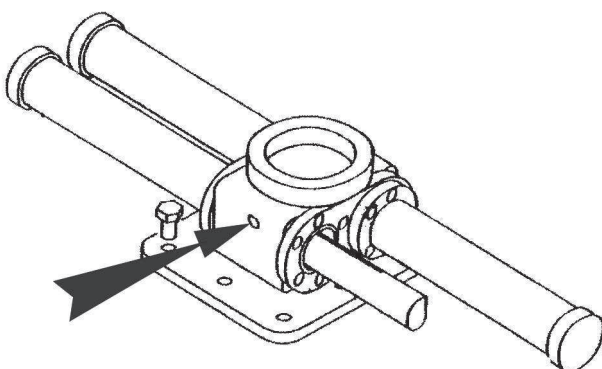

The oil level must be checked regularly. The oil level must be 1 cm below the filling plug. For the location of the plug, see the arrow above.

3.4 Lubrication schedule

Item No.	Lubricating point	C3,8 G2/ C4,6 G2/ C5,3 Qty	C4,6S/ C4,6D Qty	Lubricant	Interval, hours (work hours)
1	Turnhouse	1	1	SAE 80W/90 GL-5	50h
2	Turnhouse bearing	1	1	Lubricating grease	20h
3	Articulated joints	6	x	Lubricating grease	50h
3a	Articulated joints	x	2	Lubricating grease	50h
4	Spherical bearing	6	6	Lubricating grease	50h
5	Rotator/link	2	2	Lubricating grease	50h
6	Grapple	8	8	Lubricating grease	20h
7	Extension's wearing surfaces	x	x	Lubricating grease	50h

Recommended hydraulic oils: UTTO or STOU SAE10W/30, SAE 32, SAE 46.

PS! Use only hydraulic fluids recommended for your tractor hydraulic system by the manufacturer.

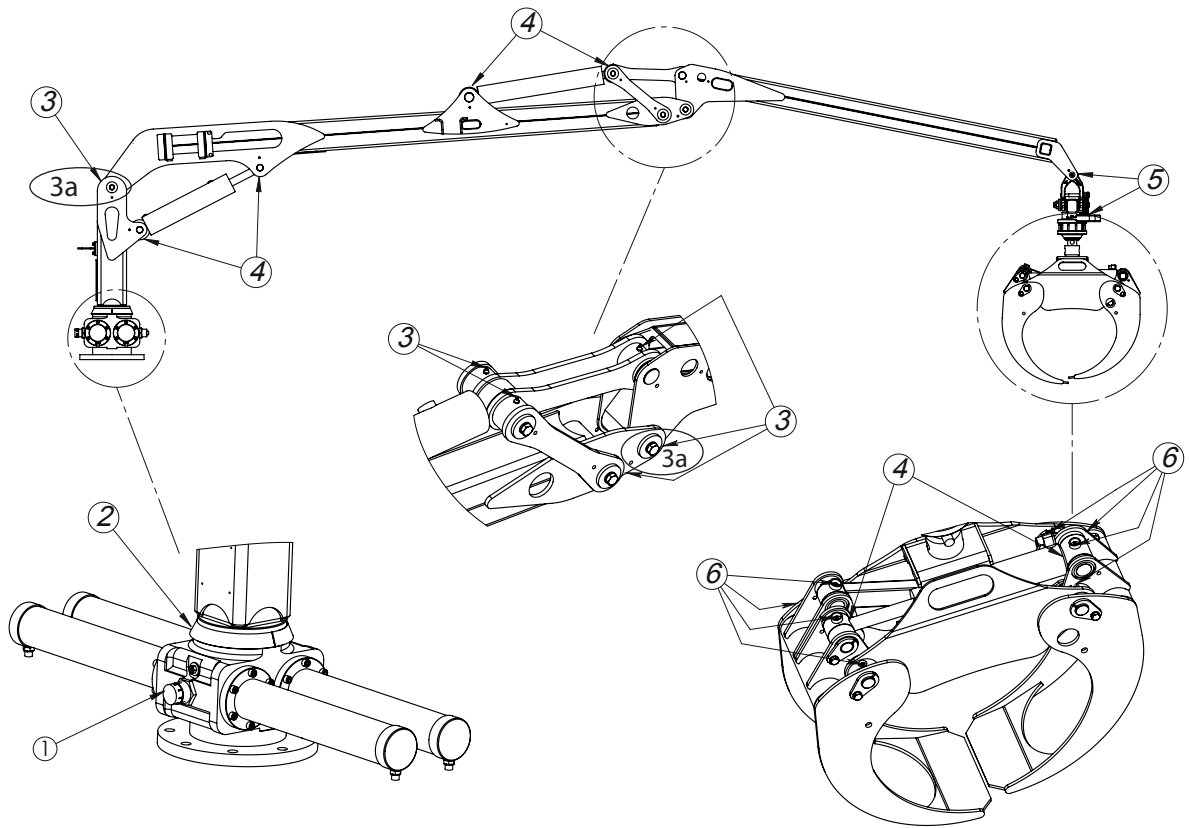

Item No.	Lubricating point	C4,2/ C6,3/ C7,0 Qty	Lubricant	Interval, hours (work hours)
1	Turnhouse	1	SAE 80W/90 GL-5	50h
2	Turnhouse bearing	1	Lubricating grease	20h
3	Articulated joints	6	Lubricating grease	50h
3a	Articulated joints	x	Lubricating grease	50h
4	Spherical bearing	6	Lubricating grease	50h
5	Rotator/link	2	Lubricating grease	50h
6	Grapple	8	Lubricating grease	20h
7	Extension's wearing surfaces	2	Lubricating grease	50h

Recommended hydraulic oils: UTTO or STOU SAE10W/30, SAE 32, SAE 46.

PS! Use only hydraulic fluids recommended for your tractor hydraulic system by the manufacturer.

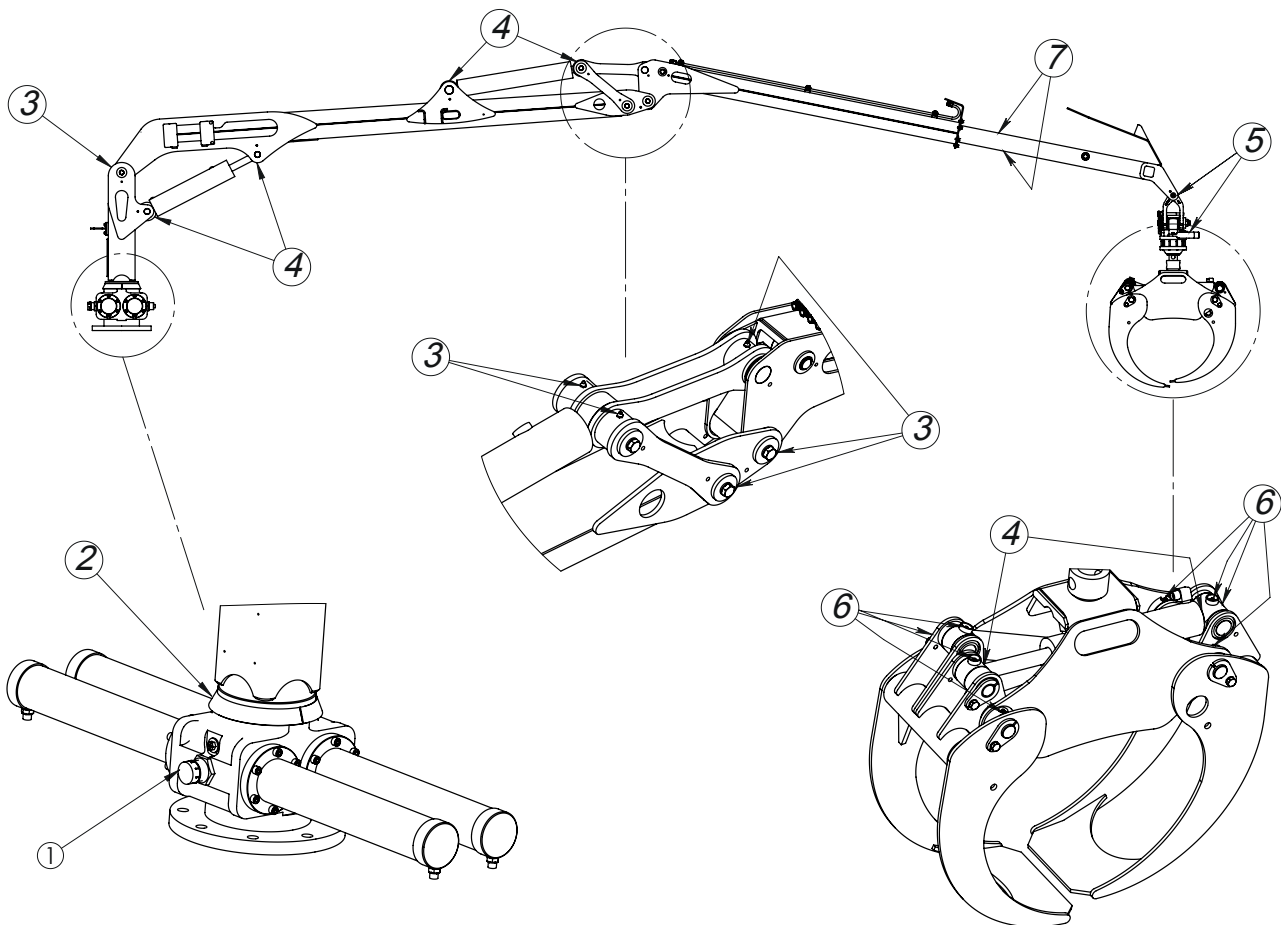

Item No.	Lubricating point	C8,5 Qty	Lubricant	Interval, hours (work hours)
1	Turnhouse	1	SAE 80W/90 GL-5	50h
2	Turnhouse bearing	2	Lubricating grease	20h
3	Articulated joints	6	Lubricating grease	50h
3a	Articulated joints	x	Lubricating grease	50h
4	Spherical bearing	6	Lubricating grease	50h
5	Rotator/link	2	Lubricating grease	50h
6	Grapple	8	Lubricating grease	20h
7	Extension's wearing surfaces	x	Lubricating grease	50h

Recommended hydraulic oils: UTTO or STOU SAE10W/30, SAE 32, SAE 46.

PS! Use only hydraulic fluids recommended for your tractor hydraulic system by the manufacturer.

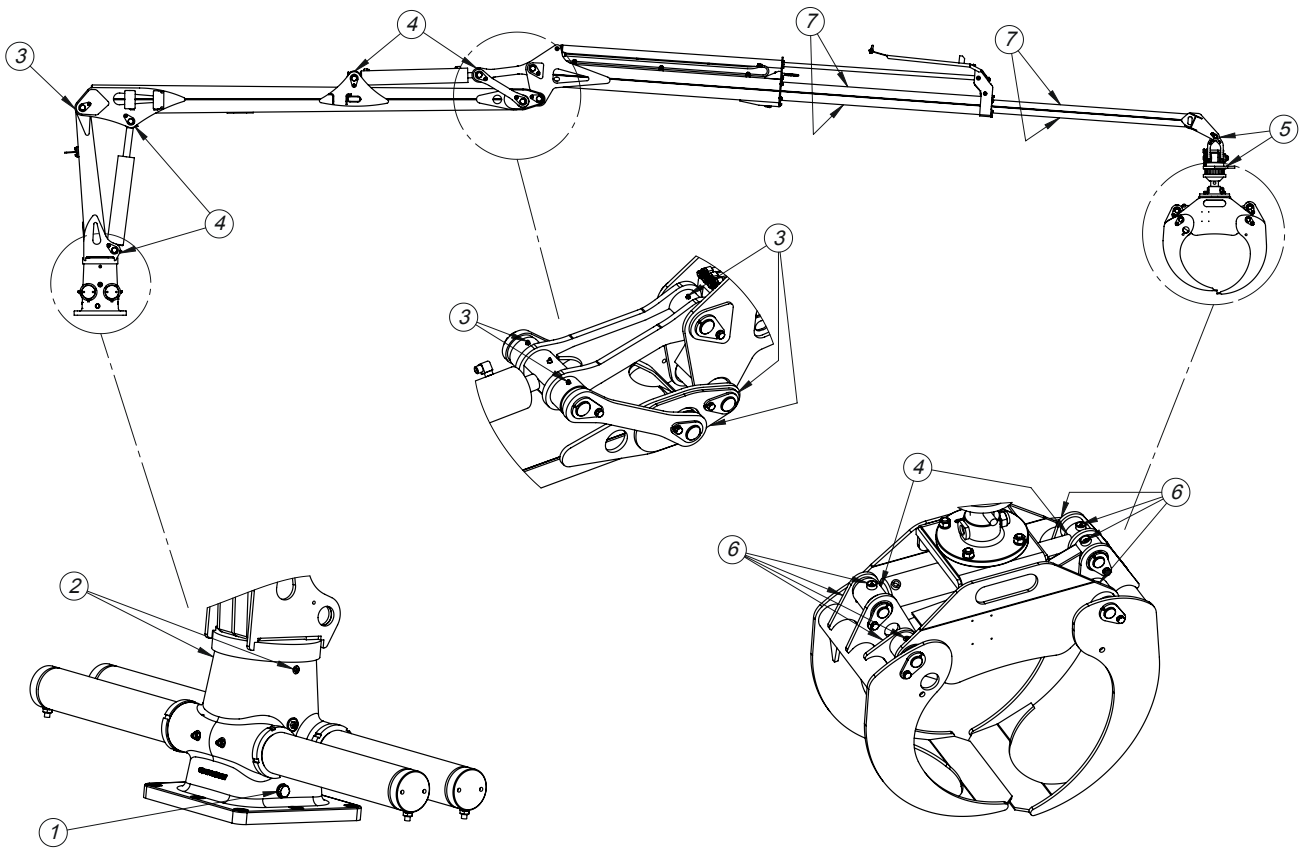

Item No.	Lubricating point	C4,0P Qty	Lubricant	Interval, hours (work hours)
1	Turnhouse	1	SAE 80W/90 GL-5	50h
2	Turnhouse bearing	1	Lubricating grease	20h
3	Articulated joints	8	Lubricating grease	50h
3a	Articulated joints	x	Lubricating grease	50h
4	Spherical bearing	6	Lubricating grease	50h
5	Rotator/link	2	Lubricating grease	50h
6	Grapple	8	Lubricating grease	20h
7	Extension's wearing surfaces	x	Lubricating grease	50h

Recommended hydraulic oils: UTTO or STOU SAE10W/30, SAE 32, SAE 46.

PS! Use only hydraulic fluids recommended for your tractor hydraulic system by the manufacturer.

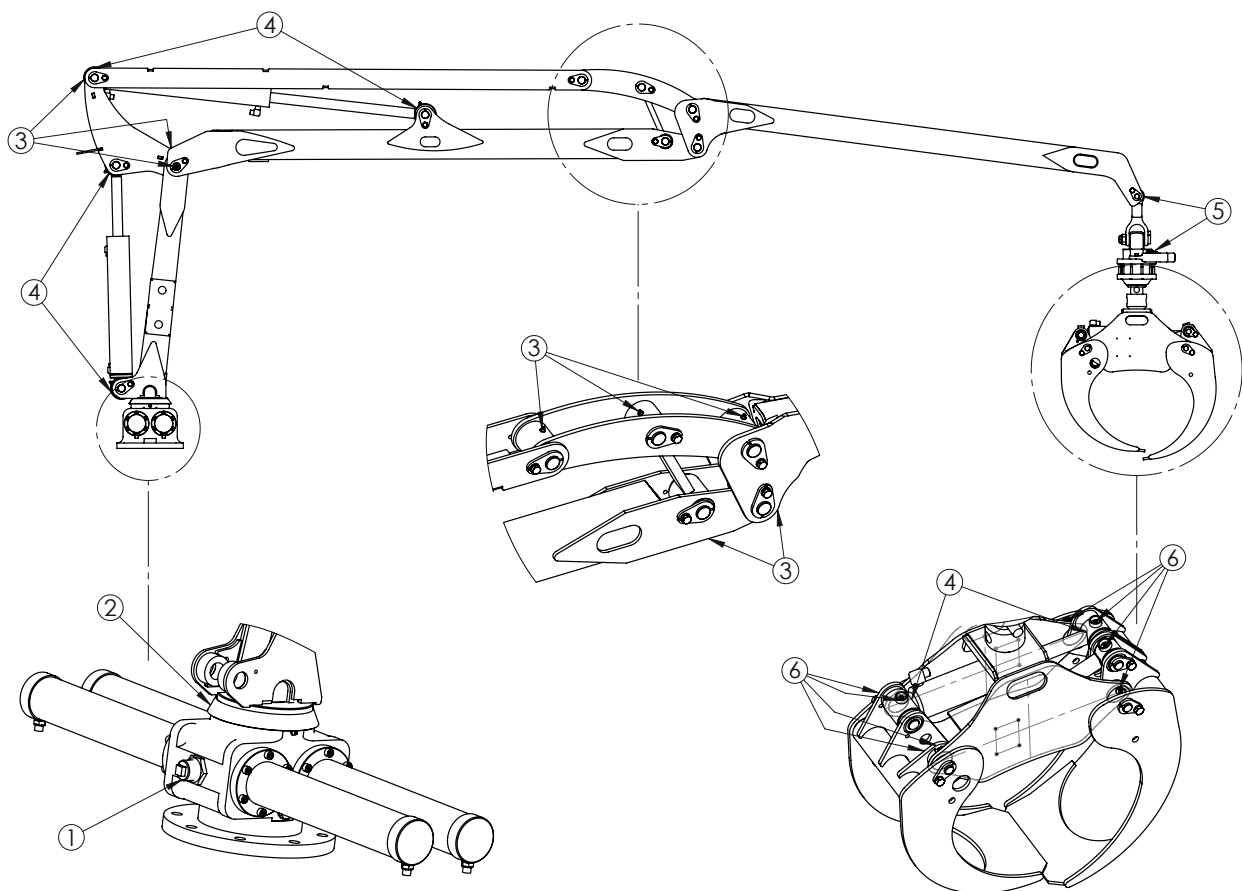

3.5 Tightening torques

The tightening torque (Mv) in Nm for untreated, oiled steel screw joints when using a torque wrench or screwdriver/wrench with torque control. Torque range max. $\pm 5\%$. Metric coarse threads. All bolts must be tightened after 10 hours of operation.

Thread M	Property class according to SS-ISO 898/1		
	8,8	10,9	12,9
5	5,7	8,1	9,7
6	9,8	14	17
8	24	33	40
10	47	65	79
12	81	114	136
14	128	181	217
16	197	277	333
18	275	386	463
20	385	541	649
22	518	728	874
24	665	935	1 120

3.6 Storage

If the crane is not going to be used for an extended period (longer than 2 months) of time, it is important to clean it carefully. Note that high-pressure washing is not recommended. After washing, all the lubricating points must immediately be lubricated. When lubricating with new grease, it forces the water away from the surfaces and thereby counteracts corrosion and wear.

To prevent the risk of rust inside the turnhouse cylinder when the crane is stored for extended periods it is recommended to fill gear oil up to the plug (see 3.3 for picture). NB! When the crane will be taken into action again it is important to detract oil from the turnhouse. It means when the crane is in use the oil level must be 1 cm below the plug (see 3.3 for picture).

- Store the crane under a roof. If this is not possible, the crane must be covered with a tarpaulin.
- Before lowering the crane onto its storage surface, ensure that the surface will not give way during the storage period, for example due to rain or the thawing of frozen soil.
- Place the boom and the grapple in the transport position.
- During storage, the crane's angle of incline must not exceed 25° in order to prevent oil running into the slewing mechanism.
- Support the crane to ensure it will not overturn during storage.

Note: A crane in storage is not a play area for children.

4 OPERATING THE CRANE

4.1 Assembling the crane

The crane is assembled on the mounting plate as per the instructions. Lubricate the bolts a little and tighten them in stages. Tightening takes place according to the tightening torques presented in point 3.5. Check that the machine's hydraulic valve is correctly equipped with regard to main limiters and chokes. The hydraulic system must be equipped with a filter for the return filter. Check that the hydraulic system is of the circulation pumping type and that it has sufficient capacity. The standard valve located on FARMA cranes is fitted with a circulation pumping system. Finally check the oil level in the turntable housing with the aid of the filling plug. For the location of this plug, see figure 3.3.

4.2 Description of functions

Note: Effective, safe operation presupposes good knowledge of cranes and extensive practical experience. Each crane model has its own specific movements, speeds and properties. For this reason, even an experienced crane operator should acquaint himself with the properties of a new crane before starting work.

The cranes in FARMA's range are hydraulically operated, which means that all their functions and movements are performed by hydraulic components, such as cylinders and rotators. The hydraulic system is an open system. This means that the oil is drawn up by a hydraulic pump from a tank and then routed under high pressure out to the relevant consumer, e.g. a rotator. Oil is then returned to the tank.

All the functions that are regulated by hydraulic valves are actuated by the user via levers. Using the controls, the user governs the extent of the flow reaching a particular cylinder in order to achieve the desired movement. Hydraulic pressure is supplied either via the tractor's hydraulic outlet or from a separate pump connected to the tractor's power take-off.

- When using the hydraulic functions, you should use them gently. Do not operate them at full speed from one position to the next. This can cause damage to hydraulic seals and other parts.
- Ensure that you always keep an eye on the load.



The crane's hydraulic valves are supplied with both main pressure limiters and choke valves to prevent the crane from being overloaded. No modifications of any type may be carried out.

4.3 Installing the crane on a tractor

Note: When you connect the crane to the tractor, you are forced to work between the machines. Be extremely carefully, as there is a risk of you being trapped.

1. Connect the drawbar to the fittings in the crane's three point linkage.
2. Secure the push rod to the tractor's existing fittings with the end closest to the point where the fittings are secured to the chassis. This ensures that the load in the push rod fittings is as small as possible.



4.4 Dismantling crane with three point linkage

1. Lower the drawbar to the ground.
2. Relieve the load on the axles for the three point linkage to make it easy to install.
3. Undo the two locking screws with locking nuts.
 - Park the crane backwards with the crane nose resting on the ground so that the crane and the support legs are stable.
 - Secure the lifting straps so that the crane is well balanced.
 - Then lift of the crane together with the three point linkage away from the trailer's vertical guide pipes.
 - Roll the trailer back so that the crane can be lowered freely to the ground.

When installing the three point linkage, the procedure is reversed.

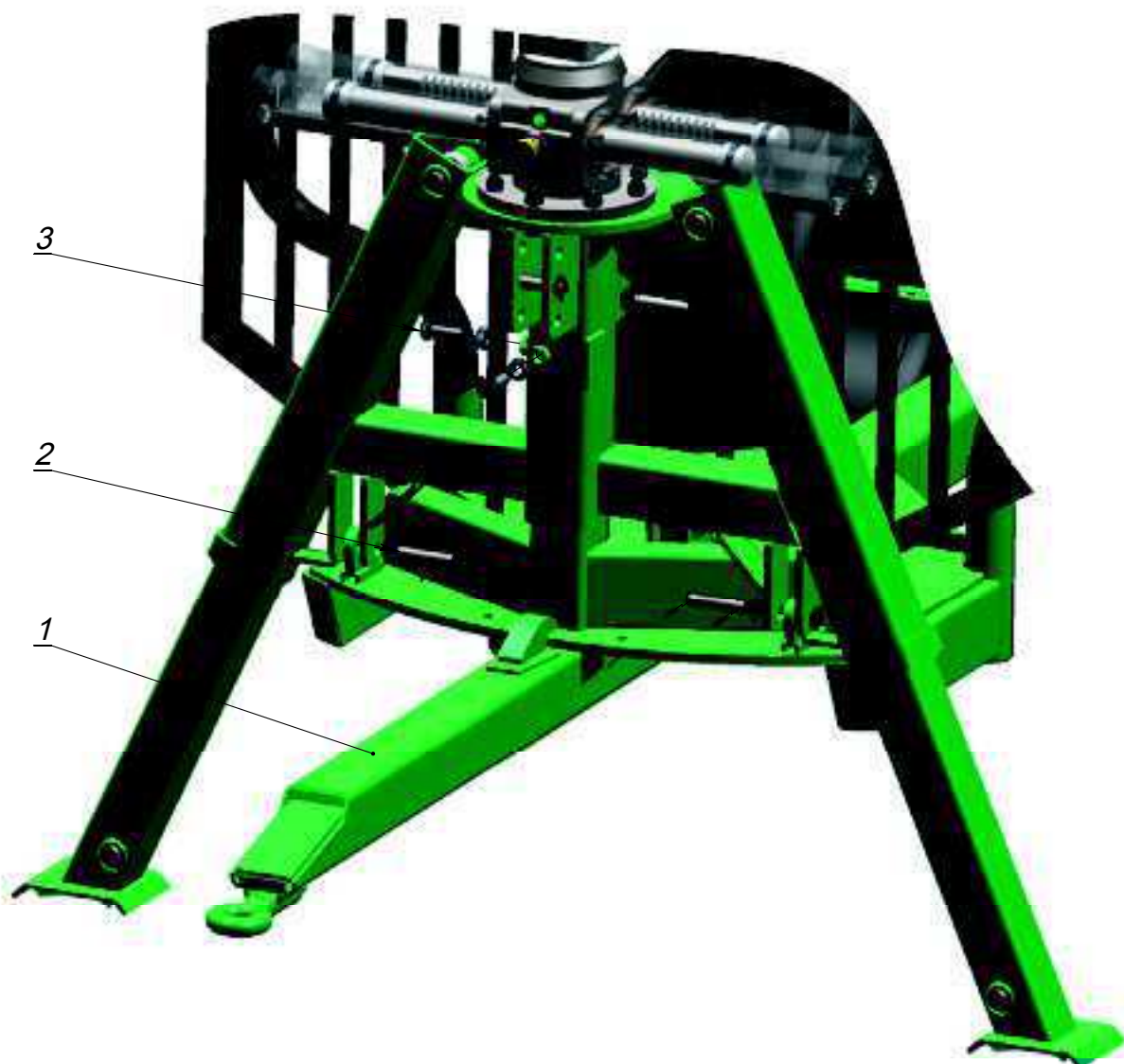

4.5 Installing the crane on a trailer

Lower the crane (1) onto the trailer's mounting plate (2). Lock with 8 bolts (3) M 20*75 8.8 DIN 931 and M 20 locking nuts (4).

See the tightening torques under point 3.5.

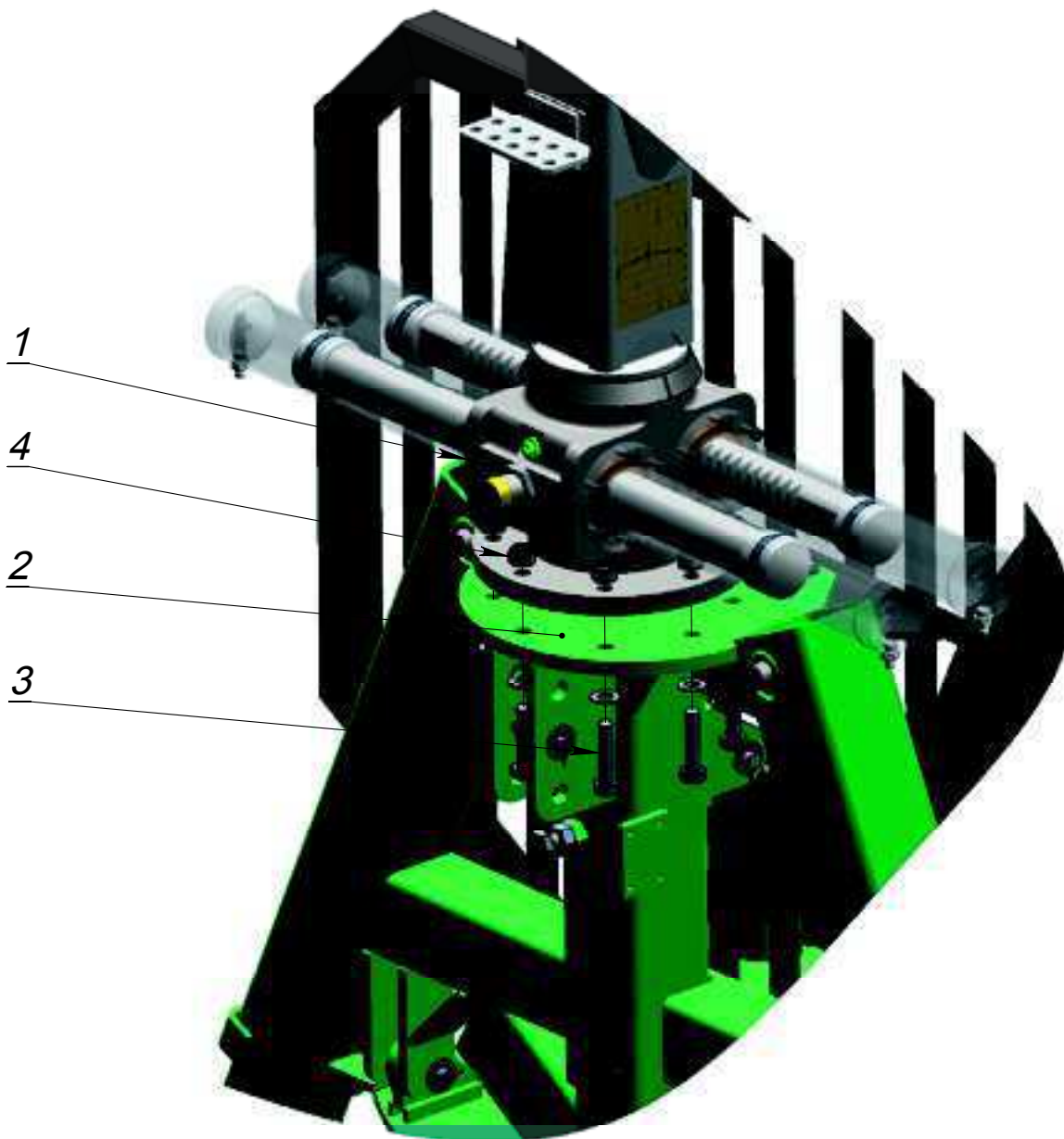

4.6 Working with the crane



It is prohibited for unauthorised parties to be within the machine's risk zone, which is 20 m.

It is worthwhile, as early as when gathering up the material for loading, to give advance consideration to the operating conditions and the crane's limitations.

Select driving lines where the loading point is on a horizontal, stable surface. Try to position the grapple piles in such a way that the timber can be loaded without the remaining tree stand being damaged. Be aware of the space that the forestry machinery requires when you want to turn in the forest. The straightest possible drag roads always cause less damage to the remaining tree stand.

Note: Remember that the stability of the machinery is impaired when loading on sloping or soft ground.



Remember

- Always use the tractor's parking brake when loading. In certain cases you can also place some form of chock in front of the wheels.
- Always use the support legs. Before loading, you must ensure that the machinery is on solid ground.
- Do not use the support legs to lift the trailer. Only use the support legs to stabilise.
- Avoid loading on slopes, although if you are forced to do so, take great care. On sloping terrain, take on smaller loads than normal.
- Take a firm grip of the load and ensure that this grip is always as close as possible to the centre of gravity. Take particular care when swinging a heavy load.
- Always pull the load towards you with the outer boom until you have achieved the required lifting force and stability.
- Do not lift higher than is necessary in order to be able to move the load freely in and out.
- Do not turn the crane until the load is at the ideal height above the ground.
- When loading is complete, the crane must be parked in the lowest possible position and the crane tip must be locked by securing the grapple to the load.
- When transporting on the road, check that the crane's maximum height is lower than the permitted loading height by a clear margin.
- To have sufficient lighting when working.

4.6.1 Working with a crane with an extension

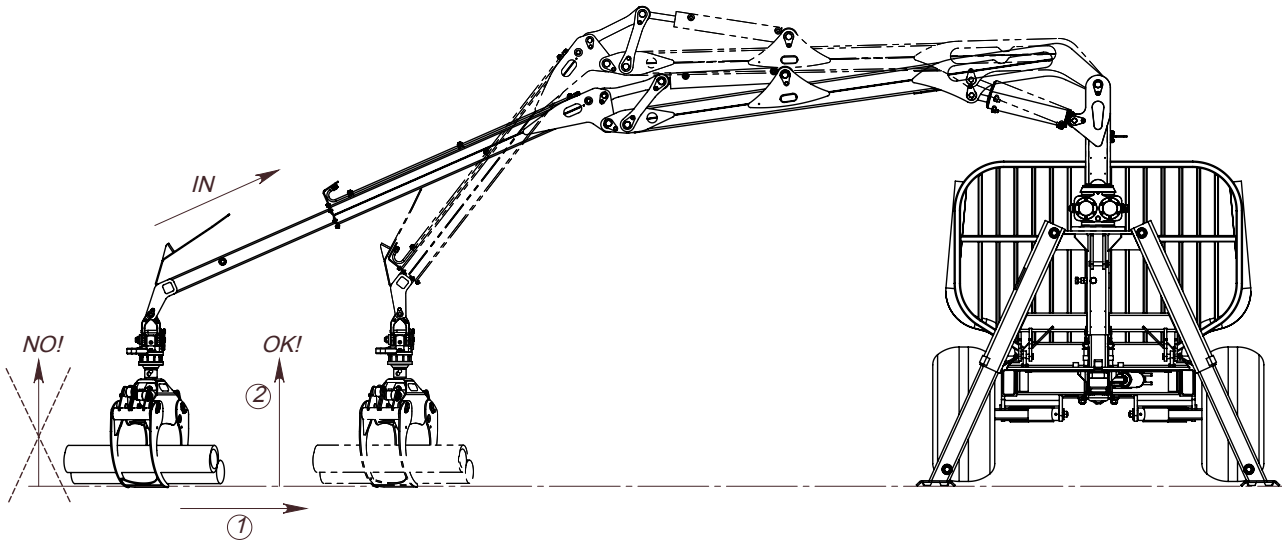

Note: When the valve is installed in the tractor, the installation must be carried out in such a way that any oil cannot reach the driver's seat in the event of a hose rupture, for example. To be sure of avoiding this, install a cover over the valve.

Note: Always connect the return hose first and then the pressure hose. Vice versa. When disconnecting the crane, the pressure hose must be disconnected first in order to avoid excess pressure.

ALWAYS LOAD WITH THE EXTENSION RETRACT.

NEVER LIFT THE LOAD AT FULL REACH.

BEFORE LIFTING THE LOAD, ALWAYS WITHDRAW THE EXTENSION.

WHEN THE EXTENSION IS WITHDRAWN, LIFT THE LOAD AND MOVE IT CLOSER TO THE CRANE PILLAR.

WHEN YOU EXTEND THE EXTENSION, ENSURE THAT THERE ARE NO OBSTACLES IN THE WAY.

MOVE THE LOAD OUT TO THE REQUIRED LOCATION AND THEN LOWER IT.

4.7 Test operating the crane

When taking the crane into use for the first time or after it has been standing for an extended period, it is important to go through this checklist.



The turning cylinders must be checked on delivery or after an extended period of downtime for the crane. If the turning cylinders have not been topped up with oil, the crane arm can swing out of control, for example when the machine is on an incline.

- The crane must always be lubricated according to the schedule in the maintenance section.
- Bolts must always be checked and if necessary tightened. See the tightening torques under point 3.5.
- The crane must always be inspected with regard to any cracks or damage to the pillar, arm and cylinders.
- Before connecting the hydraulic system, check that the control levers are in neutral.
- Check that the pressure/return hoses are correctly connected.
- Bleed the system by operating each function a couple of times. All cranes must be operated to their limit positions a few times in order to remove any air from the system.
- If necessary, top up with hydraulic fluid to the correct level.

4.8 Learning lever movements

Note: The guarantee is invalidated if a fault arises due to incorrect operation.

- Practice the control lever panel's movements. Run through each function without a load.
- The valves are proportionally controlled, which means that the speed of the function's movement is directly in proportion to the lever movement. The exceptions to this are the operation of the grapple and support legs on the joystick control, which have electrical on/off-type thumb buttons.
- Practice operating several functions at the same time. Note that the movements become slower when several functions are operated simultaneously.
- Avoid sudden movements by moving the levers gently and steadily.
- Adapt the oil flow by reducing the tractor's revs. This action helps to avoid excessively violent movements and prevents unnecessary strains, thereby providing the user with better control over the work.
- When you feel that you have mastered the crane and its functions, you can increase the rate of work. However, remember that rapid movements and excessive loads increase damage to the machine.

Start/stop instructions

Start

- Connect the hydraulic system. In cold weather, wait for 5-10 minutes until the oil has reached the correct working temperature.
- Run through all the crane's functions.

Stop

- At the end of each working day it is recommended to make 2-3 full working cycles (full turns) of the crane, to prevent the risk of rust inside the turnhouse cylinders.
- Park the crane in an appropriate manner by locking the crane arm with the aid of the grapple or by lowering the arm to the ground.
- Disconnect the hydraulic system.

4.9 Control lever panel movements

	Support legs down left		Support legs up left		Turn left
	Support legs down right		Telescope out		Turn right
	Support legs up left		Telescope in		Lift arm down
	Support legs up right		Grapple close		Lift arm up
	Support legs down left		Grapple open		Outer boom down (in)
	Support legs down right		Rotator anti-clockwise		Outer boom up (out)
	Support legs up right		Rotator clockwise		

4.10 Control lever panel movements for each control

5 LEVER STD.

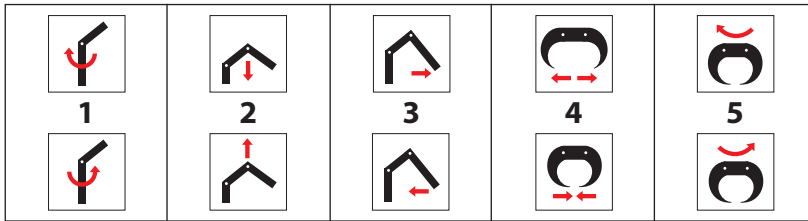

6 LEVER STD.

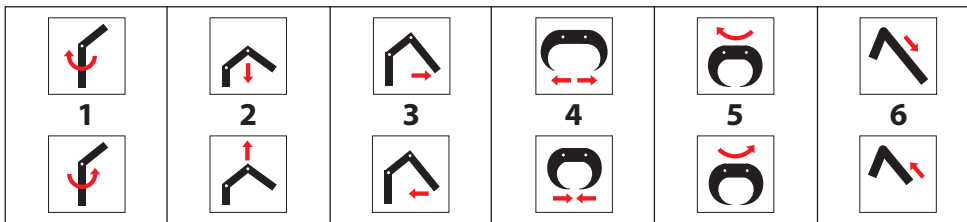

7 LEVER STD.

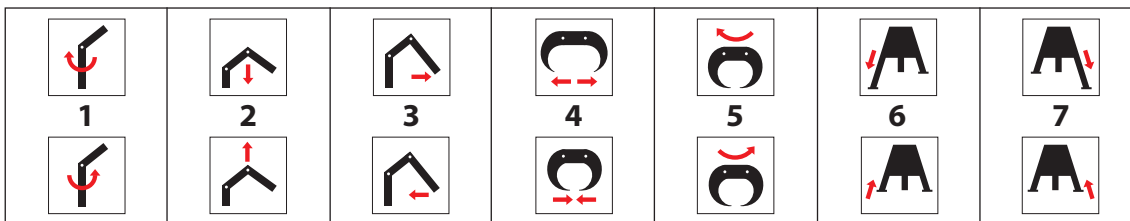

8 LEVER STD.

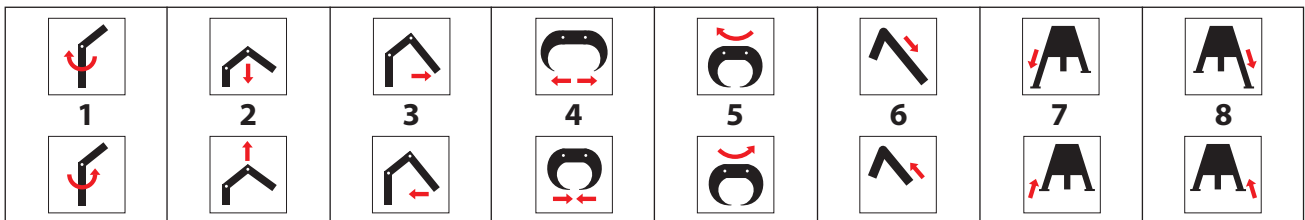

2+3 MECH. 2-LEVER

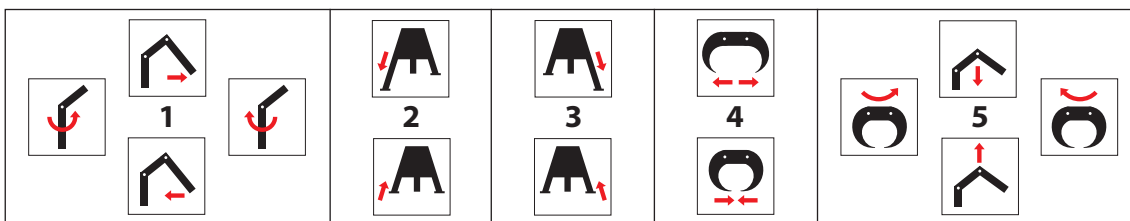

2+4 MECH. 2-LEVER

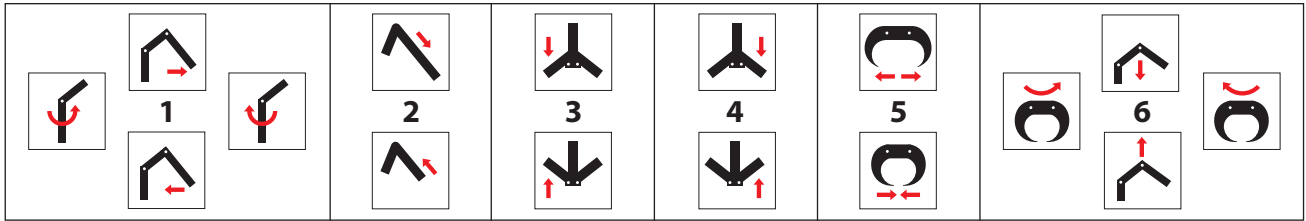

2+3 ELECTRICAL ON-OFF

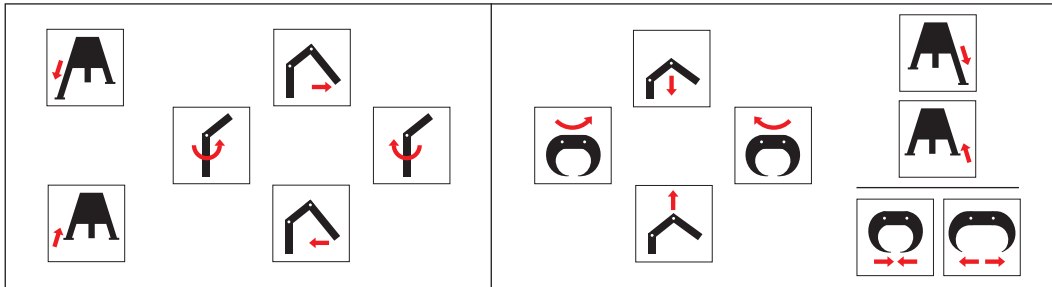

2+4 ELECTRICAL ON-OFF

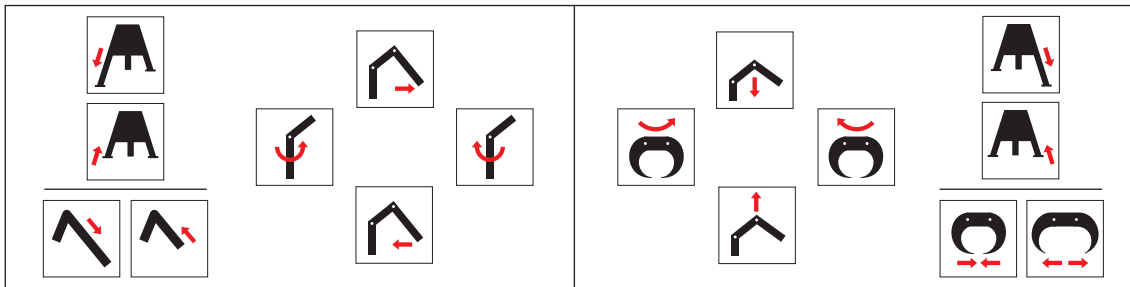

FARMA Cranes Main Dimensions

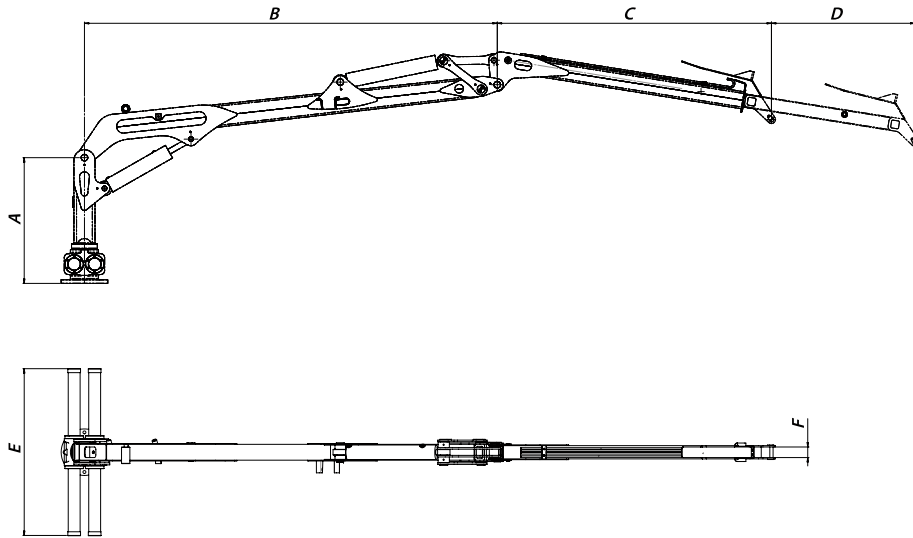

	A mm	B mm	C mm	D mm	E mm	F mm
C 3.8 G2	960	2 200	1 650	–	960	50
C 4.2 G2	960	2 200	1 410	595	960	50
C 4.6	950	2 660	1 920	–	1 270	50
C 4.6 G2	950	2 840	1 780	–	1 270	50
C 5.1	950	2 960	2 110	–	1 270	50
C 5.3 G2	950	3 150	2 150	–	1 270	60
C 6.3 G2	950	3 150	2 100	1 100	1 270	60
C 7.0 G2	1 590	3 370	2 340	1 300	1 500	60
C 8.5 G2	1 590	3 370	2 340	2 900	1 500	60

All dimensions in the figures are in mm.

For additional information about crane sizes, movement patterns and specifications please refer to the matrix and technical data in this brochure and to www.forsmw.com, where detailed information is available.

FARMA Cranes Technical Data

	Lifting capacity, net kNm	Lifting power, kg/max. reach**	Slewing torque, kNm	Slewing angle, degrees	Reach, m	Telescopic stroke length, m	Recommended flow, l/min	Working pressure, bar	Weight of crane, kg	Weight, kg incl. 0.12 grapple*	Weight, kg incl. 0.16 grapple*	Weight, kg incl. 0.20 grapple*	Weight, kg incl. 0.24 grapple*
										*The weights include grapple, rotator and link			
C 3.8 G2	18	475	3	370	3.8	X	10-35	175	290	365	385	X	X
C 4.2 G2	18	430	3	370	4.2	0.6	10-35	175	310	385	405	X	X
C 4.6S	23	475	4.4	360	4.6	X	20-50	175	430	505	525	585	X
C 4.6S G2	23	555	4.4	360	4.6	X	20-50	175	400	475	495	505	X
C 4.6D	23	475	8.8	360	4.6	X	20-50	175	460	535	555	595	X
C 4.6D G2	23	555	8.8	360	4.6	X	20-50	175	430	505	525	565	X
C 5.1	30	450	8.8	360	5.1	X	20-50	175	530	605	625	665	X
C 5.3 G2	30	565	8.8	360	5.3	X	20-50	175	580	655	675	715	X
C 6.3 G2	28	440	8.8	360	6.3	1.1	20-50	175	630	X	725	765	X
C 7.0 G2	48	720	16	380	7	1.3	40-70	190	810	X	X	945	985
C 8.5 G2	45	520	16	380	8.5	2.9	40-70	190	850	X	X	985	1025

** Lifting power is excluding grapple, rotator and link.
Numbers can be rounded off to the nearest whole number.

We reserve the right to alter specifications without prior notice. Figures for the measurements are only of illustrative purpose.