

v2 - 2025 EN

INSTRUCTION MANUAL

Original instruction book

FARMA®

**Instruction
manual
Grapple/Rotator**

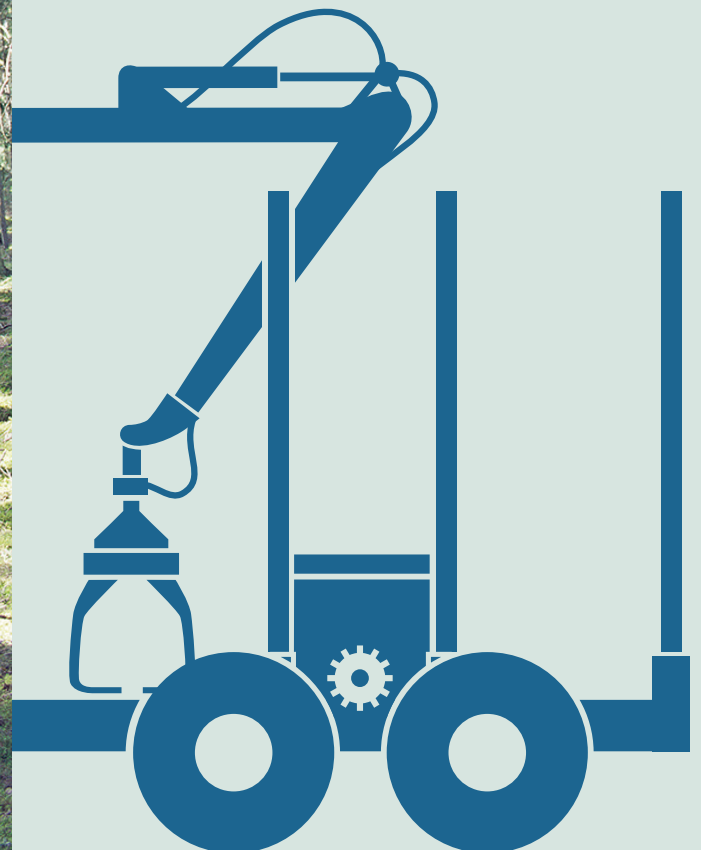

 **FORS MW**

CONTENTS

1 INTRODUCTION 3

2 SAFETY REGULATIONS..... 4

2.1 DESCRIPTION FOR THE USE OF WARNING SYMBOLS 4

2.2 GENERAL SAFETY REGULATIONS 4

2.3 INSTRUCTIONS FOR SAFE USE 4

2.4 LOCATION OF DECALS ON THE GRAPPLE 5

2.5 PRESENTATION OF DECALS 5

3 INSTRUCTIONS FOR SAFE USE 7

3.1 TECHNICAL DESCRIPTION 7

3.2 TECHNICAL DATA 8

3.3 TIGHTENING TORQUES 10

4 INSTALLATION 11

4.1 ASSEMBLY 11

5 MAINTENANCE/SERVICE 12

1 INTRODUCTION

This instruction manual is intended for FARMA grapples and rotators, and contains information for safe use. FARMA grapples are intended for automatic work in the fields of agriculture and forestry. The grapple is intended to be mounted on a forestry crane. The permitted load values may not be exceeded under any circumstances.

Even if you have experience of this type of product, we recommend that you read our instructions carefully in order to familiarise yourself with the product. The instructions contain information that is vital for safety and efficiency, as well as to ensure the validity of the factory guarantee. When the product you have purchased is delivered, check that it has not sustained any delivery or transport damage. If there should be any such damage, or if any parts are missing, contact your dealer immediately.

It is the responsibility of the user to inform himself regarding the use of the product and to follow the instructions carefully. It is also the responsibility of the user to ensure that attachments and connections are designed and adapted in such a way that they achieve what the grapple is intended to handle by a clear margin.

Fors MW reserves the right to make changes to equipment and maintenance instructions and to revise its data without prior notice.

This instruction manual refers to grapples under the name of Farma Generation 2. This range is made of Weldom 700 high strength steel. Fors MW offers two rotator sizes, 3 and 4 tonnes. You can see on the actual product which rotator you should use with your grapple.

Manufacturer:

AS FORS MW
TULE 30
765 05 SAUE
Tel: + 372 679 00 00
www.forsmw.com

Dealer:

2 SAFETY REGULATIONS

2.1 Description of the use of warning symbols

In the instruction manual, we distinguish between the terms Warning and Note. These markings are used to draw the attention of readers to the fact that this is an area that is of particular importance.

Warning! = A very important item of safety information is supplied with this warning symbol. Warnings refer to the risk of injury or death for people, as well as the risk of serious damage to the equipment.

Note: = The Note symbol indicates that the product, process or environment may sustain damage, as well as indicating the risk of minor injuries.

2.2 General safety regulations



Carefully read through the instruction manual before using the grapple. Important data relating to your particular grapple can be found in the technical data. Incorrect usage can result in injuries to you and damage to the machinery.

Operating a grapple requires a high level of expertise, as well as knowledge about the machine you are using. It is important for you to acquire knowledge and to train with regard to the behaviour of the crane and the grapple. Take care to ensure that nobody is within the safety zone (20 m). When handling timber, large forces are used to handle heavy masses. By adhering to the indicated safety regulations and the grapple's technical data, neither the user's nor the machine's safety are put at risk.

FARMA's grapples are intended for normal use within agriculture and forestry, and may only be used by individuals who possess general knowledge about the handling of agricultural machinery.

2.3 Instructions for safe use



It is prohibited for unauthorised parties to be within the machine's risk zone, which is 20 metres.

Note: The tractor must be switched off when performing any connections to or disconnections from the hydraulic system, as well as during service work. This is because the hydraulic pump and the power take-off must be switched off.

Note: Carefully check that all movements are working as intended.

Carefully read through the section about the grapple before starting to work with it. Use loading tools that are sufficiently dimensioned for the loads to be lifted. Incorrect usage can result in injuries to you and damage to the machinery.

2.4 Location of the decals on the grapple

The grapple is equipped with a range of signs relating both to safety and information. Check that all the signs are in the correct positions.

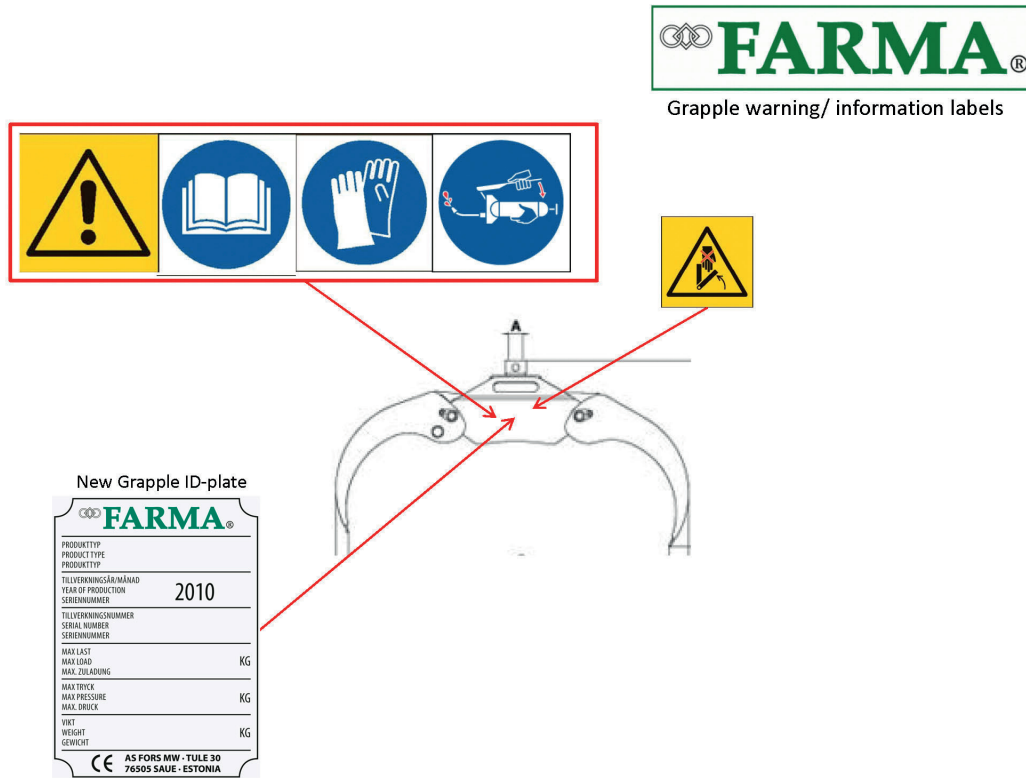

2.5 Presentation of decals



Warning triangle and instruction manual decal

The grapple is supplied with a warning triangle alongside the instruction manual decal in order to clarify the requirement for the user to read the entire instruction manual carefully before starting to use the grapple. Ignoring this can entail a danger to life.



Decal for the use of safety equipment

These decals challenge the user to employ appropriate safety equipment in order to avoid injury when using the grapple.

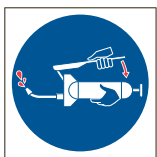

Lubrication

This decal is used to show the importance of regular lubrication of the grapple.



Risk of clamping injuries

There is a risk of clamping or crushing injuries during work and maintenance.



FARMA designation plate

Each grapple that is delivered is supplied with a designation plate. Ensure that the grapple has this plate and check the data contained on the plate.

3 INSTRUCTIONS FOR SAFE USE

3.1 Technical description

Below is a description of the two main parts when purchasing a grapple, i.e. the grapple and the rotator.

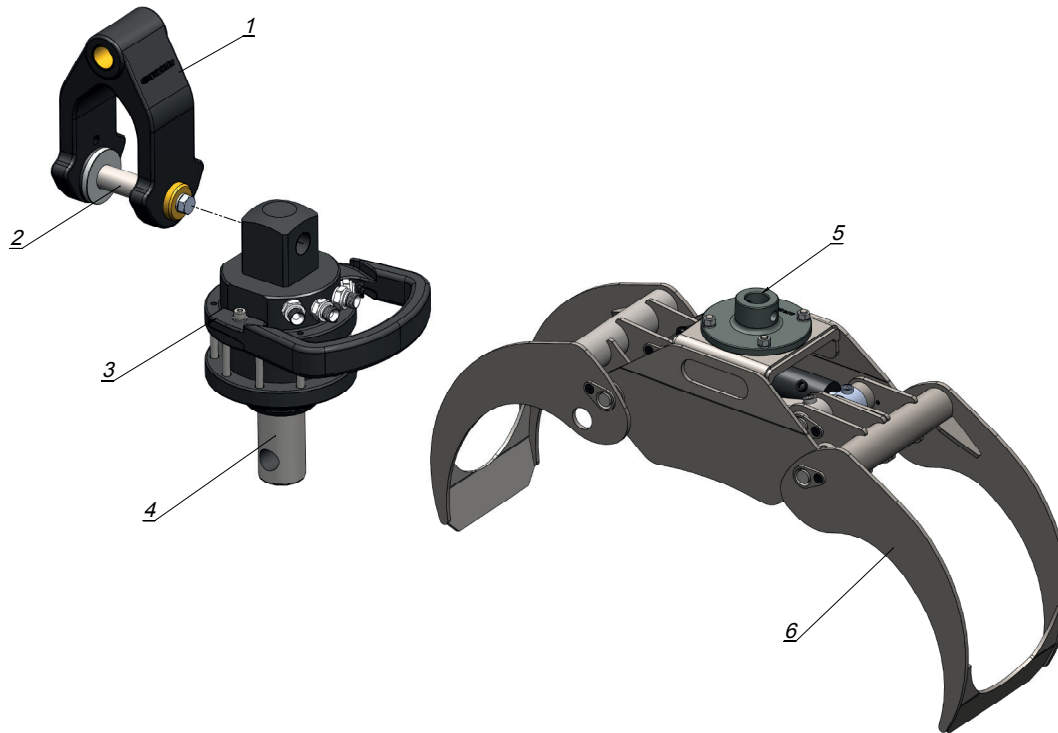

- 1 Link
- 2 Link shaft
- 3 Rotator
- 4 Rotator shaft
- 5 Flange plate
- 6 Grapple claw

3.2 Technical data

Grapple G 2.1

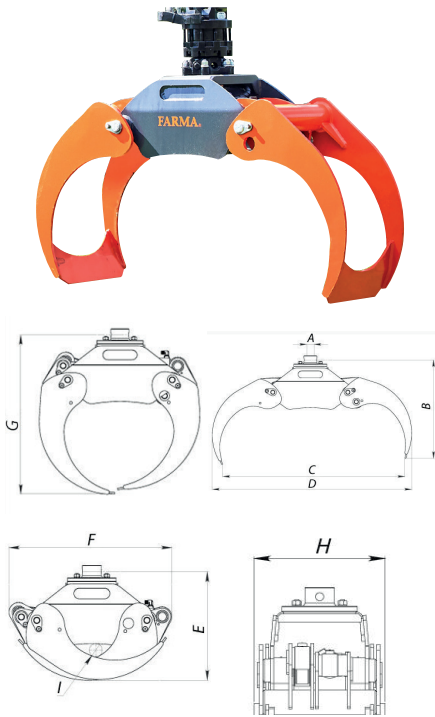

Measure	0,12 m ²	0,16 m ²	0,20 m ²	0,24 m ²	0,28 m ²
A	Ø 50 mm	Ø 50 mm	Ø 50/60 mm	Ø 50/60 mm	Ø 50/60 mm
B	630 mm	715 mm	700 mm	815 mm	865 mm
C	875 mm	1 045 mm	1 255 mm	1 275 mm	1 550 mm
D	1 010 mm	1 225 mm	1 380 mm	1 470 mm	1 700 mm
E	425 mm	510 mm	510 mm	530 mm	630 mm
F	600 mm	715 mm	745 mm	785 mm	870 mm
G	625 mm	730 mm	800 mm	860 mm	900 mm
H	280 mm	280 mm	370 mm	395 mm	480 mm
I	Ø 55 mm	Ø 80 mm	Ø 70 mm	Ø 65 mm	Ø 80 mm

Technical data	0,12 m ²	0,16 m ²	0,20 m ²	0,24 m ²	0,28 m ²
Weight	53 kg	70 kg	115 kg	145 kg	230 kg
Working Pressure	17.5 MPa	17.5 MPa	17.5 MPa	21.0 Mpa	23.0 Mpa
Gripping force arms tip-tip	6,3 kN	7,0 kN	8,25 kN	11,0 kN	15.0 kN
Max.load	1 000 kg	1 000 kg	1 500 kg	2 000 kg	3 500 kg
Size, rotator mount	50	50	<u>50</u> /60*	50/ <u>60</u> *	50/ <u>60</u> *

* This model is supplied with a replaceable rotator mount. Specify the desired mount when ordering. The underlined figure is the standard option.

Insert buckets G 2.1

Insert buckets for the use together with Generation 2 grapples

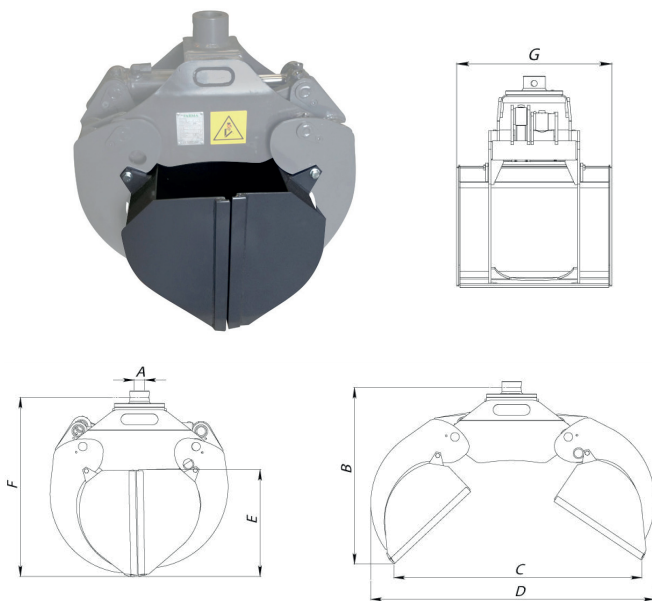

Measure	0,12 m ²	0,16 m ²	0,20 m ²
A	Ø 50 mm	Ø 50 mm	Ø 50/60 mm
B	695 mm	750 mm	770 mm
C	795 mm	1045 mm	1280 mm
D	975 mm	1225 mm	1380 mm
E	390 mm	435 mm	490 mm
F	670 mm	765 mm	830 mm
G	525 mm	525 mm	625 mm

Technical data	0,12 m ²	0,16 m ²	0,20 m ²
Weight	36 kg	40 kg	55 kg
Working Pressure	17.5 MPa	17.5 MPa	17.5 MPa
Gripping force arms tip-tip	6.3 kN	6.8 kN	8.2 kN
Volume	58 l	80 l	110 l
Max.load	500 kg	500 kg	750 kg

Energy brush grapple G 2.1

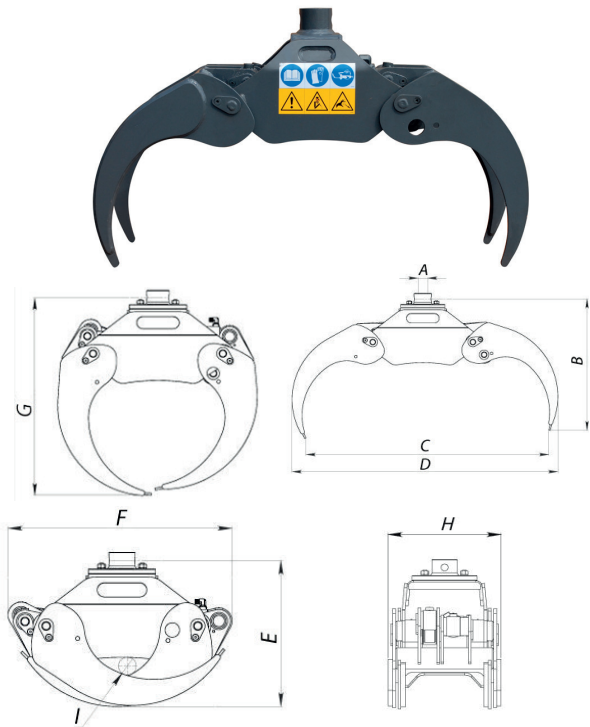

Measure	0,12 m ²	0,16 m ²	0,20 m ²
A	Ø 50 mm	Ø 50 mm	Ø 50/60 mm
B	615 mm	690 mm	670 mm
C	875 mm	1 065 mm	1 265 mm
D	1 010 mm	1 230 mm	1 380 mm
E	425 mm	505 mm	510 mm
F	585 mm	725 mm	745 mm
G	640 mm	730 mm	800 mm
H	290 mm	305 mm	400 mm
I	Ø 40 mm	Ø 75. mm	Ø 70 mm

Technical data	0,12 m ²	0,16 m ²	0,20 m ²
Weight	57 kg	85 kg	230 kg
Working Pressure	17.5 MPa	17.5 MPa	23.0 MPa
Gripping force arms tip-tip	6.0 kN	6.5 kN	15.0 kN
Max.load	1 000 kg	1 000 kg	3 500 kg
Size, rotator mount	50	50	<u>50/60*</u>

*This model is supplied with a replaceable rotator mount.
Specify the desired mount when ordering. The underlined figure is the standard option.

Grapple bucket G 2.1

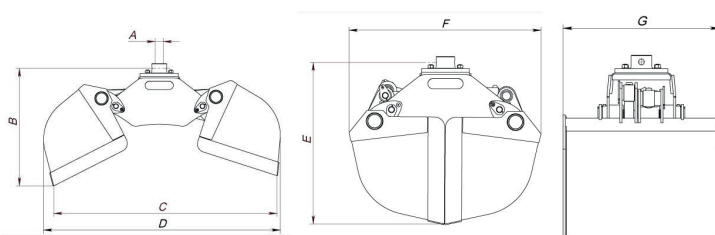

Measure	160 l	200 l
A	Ø 50/60 mm	Ø 50/60 mm
B	705 mm	705 mm
C	1 355 mm	1 355 mm
D	1 420 mm	1 420 mm
E	785 mm	785 mm
F	925 mm	925 mm
G	555 mm	685 mm

Technical data	160 l	200 l
Weight	172 kg	182 kg
Size, rotator mount	<u>50/60*</u>	<u>50/60*</u>
Working Pressure	19.0 MPa	19.0 MPa
Gripping force arms tip-tip	9.0 kN	9.0 kN
Volume	160 l	200 l
Max.load	1 000 kg	1 000 kg

* This model is supplied with a replaceable rotator mount.
Specify the desired mount when ordering. The underlined figure is the standard option.

3.3 Tightening torques

The tightening torque (Mv) in Nm for untreated, oiled steel screw joints when using a torque wrench or screwdriver/wrench with torque control. Torque range max. $\pm 5\%$. Metric coarse threads. All bolts must be tightened after 10 hours of operation.

Thread M	Property class according to SS-ISO 898/1		
	8.8	10.9	12.9
5	5.7	8.1	9.7
6	9.8	14	17
8	24	33	40
10	47	65	79
12	81	114	136
14	128	181	217
16	197	277	333
18	275	386	463
20	385	541	649
22	518	728	874
24	665	935	1 120

4 INSTALLATION

4.1 Assembly



Leakage in the hydraulic lines can result in the grapple dropping the load.

Note: The crane must be securely anchored when assembling the grapple.

- If this is not done, the grapple must be placed on a flat, stable surface on delivery.
- Bear in mind the risk of clamping injuries when assembling the grapple.

Note: Incoming hoses from valves are connected as shown in the figure below:

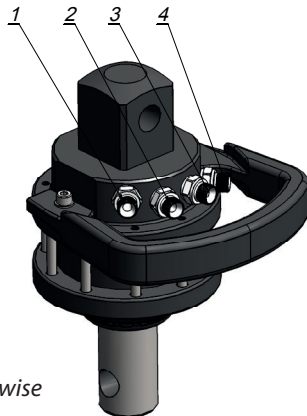

- 1 Open grapple
- 2 Rotation clockwise
- 3 Rotation anti-clockwise
- 4 Close grapple

- The grapple must be coupled to the lower connection on the rotator.
- Place the folded grapple on the surface directly behind the crane.
- Extend the crane and lower the rotator shaft into the grapple sleeve. Then switch off the hydraulic pump.
- Knock through the shaft journal and install the lock.
- The hydraulic hoses must be installed securely to avoid them becoming worn, hanging down, being stretched or trapped.
- The hydraulic hoses on the grapple cylinder must be connected to the rotator shaft's connections. Note! If the hoses are connected incorrectly, leakage can occur as a result of excess pressure in the rotator.
- Connect side 2 (opening side) of the grapple cylinder to the port on the rotator shaft marked Open.
- Connect side 1 (closing side) of the grapple cylinder to the port on the rotator shaft marked Close.
- Finally, test operate the grapple. Check that the grapple closes and opens correctly.
- In the event of any leaks, tighten the leaking connections.

5 MAINTENANCE/SERVICE

Regular and correct maintenance is a precondition in order for the guarantee to be valid. Failure to comply with the rules will invalidate the guarantee.

Note: When servicing the grapple, you must always ensure that you avoid slipping and clamping injuries.

Note: When replacing hoses, always test operate the machine according to the installation section to ensure that everything is properly connected.

Grapple hydraulics

- Repair work on hydraulic components must be performed in clean premises. Clean the outside of the components carefully before taking them apart, to ensure that dirt does not enter the system.
- Never leave the system open. Always block hose and port openings with clean plastic plugs to avoid dirt entering the system.

Lubrication schedule

Note: Lubricating grease containing graphite may not be used.

Note: If dirt enters the bearing during lubrication, this can cause wear.

The grapple and the rotator must be lubricated according to the lubrication schedule every 8 operating hours.

