



**BIGAB**

**7-10**

**8-12**

**10-14 / 10-14 G2**

**12-15 / 12-15 G2**

**14-17**

EN\_V1.1-2020W42

Original instructions

# INSTRUCTIONS BOOK

## TABLE OF CONTENTS

IDENTIFICATION OF MACHINE .....	2
INTRODUCTION .....	3
SAFETY REGULATIONS.....	4
GENERAL SAFETY INFORMATION .....	4
SAFETY MESSAGES .....	4
LOCATION OF THE LABELS ON THE PRODUCT .....	5
OPERATION .....	8
CONTROLS AND DISPLAYS .....	8
UNLOADING TRAILER .....	8
BEFORE OPERATION .....	9
CONNECTING MACHINE .....	10
WORKING IN EXTREME CONDITIONS .....	14
DISCONNECTING THE TRAILER .....	15
CLEARING BLOCKAGES AND CLEANING.....	15
TRANSPORT .....	15
MAINTENANCE .....	16
DAILY/MONTHLY/YEARLY MAINTENANCE PROCEDURES AND INSPECTION.....	17
MAINTENANCE MATERIALS .....	21
TIGHTENING TORQUES.....	22
LUBRICATION SCHEDULE.....	23
STORAGE .....	24
CLEANING.....	24
TROUBLESHOOTING .....	24
TECHNICAL INFORMATION .....	26
DESIGN OF THE PRODUCT .....	26
TECHNICAL DATA.....	29
DIMENSIONAL DRAWING.....	33
ELECTRICAL AND HYDRAULICAL SYSTEM .....	34
ADDITIONAL INFORMATION .....	43
CONFORMITY OF STANDARDS .....	43
WARRANTY.....	43
DISMANTLING AND SCRAPPING.....	43
PART LIST .....	43

Original Instruction

## IDENTIFICATION OF MACHINE

This instruction manual applies to the BIGAB hooklift trailers 7-10, 8-12, 10-14, 12-15, 10-14 G2, 12-15 G2 and 14-17 and contains information for its safe use.

Serial number of the trailer is located in identification plate and also stamped into the frame.

EC declaration of conformity shall be submitted always with this manual which certifies that the produced vehicle conforms to the requirements established with directive 2006/42/EC and indicating serial number of the machine.

### *EC Declaration of Conformity of the Machinery (sample)*

Manufacturer:  
**Fors MW AS**  
Tule 30  
76505 Saue  
Estonia

The technical file is compiled by CEO  
I hereby confirm that this **complete trailer BIG-AB 15-19**:

Trade mark: **BIGAB**  
Function: **complete hook lift trailer**  
Model: **xx-xx**  
Type: **BH** variant: **xx-xx**  
VIN: **V60BHxxxx**-----  
Trade name: **BIGAB xx-xx**  
Manufacture year: -----

is manufactured accordingly to demands in **directive 2006/42/EC** and therefore can be used mounted together with other equipment to provide a complete machine.

The equipment can't be used before the machine or the formation that it will take place in, is accordingly to the demands of the EC Machinery directive.

For the guarantee and safety, it is of uttermost significance that the instruction book is read before the machine is put into service.

Saue, Estonia 2020-10-06

SIGN  
CEO

## INTRODUCTION

This Manual gives the owner/operator information about maintaining and servicing BIGAB hooklift trailer and provides instruction for safe and proper use of the machine.

Even if you have experience of this type of product, we ask that you read and understand the contents of this manual completely and become familiar with your new machine before operating it. This Manual contains information that could be vital for safety and efficiency, as well as to ensure the validity of the factory warranty.

If you have questions concerning information or availability of manuals in other languages, contact your dealer.

Throughout this manual, information is provided by the sign  - read carefully and comply with these messages – it will improve your operating and maintenance efficiency, help avoid breakdowns and damage and extend your machine's life.

Message **NOTE!** indicates that the product, process or environment may cause damage, as well as indicating the risk of minor injuries. These markings are used to draw the attention of readers to the fact that this is an area of particular importance.

Do not use this machine for any applications or purposes other than those described in this manual or applicable for approved attachments. If the machine is to be used with special attachments or equipment other than those approved by Fors MW, consult your dealer. Any person using unapproved attachments or making unauthorized modifications is responsible for the consequences.

The dealers are ready to provide you with any assistance you may require, including providing genuine service parts. All serviceparts should be obtained from your dealer. Provide complete information about the part and include the model and serial numbers of your machine.

Please be aware that Fors MW continuously improves its products and reserves the right to make changes and improvements in the design, construction and also in instructions of any part without obligation to install such changes on any unit previously delivered.

Fors MW conforms to ISO 11647 for safety marking in accordance with the directive 2006/42/EC.

### CONTACT INFORMATION:

**Manufacturer:**

AS FORS MW

Tule 30

765 05 Saue

Estonia

Tel: + 372 679 00 00

Fax: + 372 679 00 01

E – mail: [info@forsmw.com](mailto:info@forsmw.com)

**Dealer:**

## SAFETY REGULATIONS

### GENERAL SAFETY INFORMATION



**Carefully read through the user manual before using the hook lift trailer. Important data relating to your particular trailer can be found in the trailer's technical data. Incorrect usage can result in injuries to you and damage to the trailer.**

Operating a trailer requires a high level of expertise, as well as knowledge about the machine you are using. It is important for you to train with regard to the trailer's behaviour. Practice the movement pattern and always work with smaller loads until you are completely familiar with operating the trailer.

BIGAB Hooklift is intended for use in agricultural, construction and community work for collection and transportation of waste, scrap, agricultural and other goods.

Bigab Hooklift is not intended to use for transporting people or animals.

Take care to ensure that nobody is within the safety zone 20 m.

The recommended ambient working temperature for this machine is -30°C to +40°C.

### SAFETY MESSAGES

- Read carefully and understand the user manual before using the device. Consult the user manual to solve your problems.
- Follow the instruction to avoid the risk of accidents. The manufacturer and dealer are not responsible for any damage in the event of failure to comply with these instructions.
- It is prohibited for unauthorised parties to be within the trailer's risk zone, which is 20 m! The user must have full visual control over the working area. Always maintain a visual check on the work area. Never stand or walk under suspended loads.
- It is important for you to adapt your speed to the driving situation. Drive carefully on sideways inclines. The same applies on slopes.
- Never drive under obstacles such as bridges, electrical cables, etc with the container bridge raised.
- Risk of overturning. Ensure that the trailer is always standing on firm ground. Never overload the trailer.
- Stop working by switching off the engine, engage the parking brake and remove the ignition key to prevent unauthorised usage.
- Carefully read through the warning information on the oil and grease products you are using, and follow their instructions accurately! During service works wear correct

Original Instruction

protective equipment and seek medical attention immediately exposed to skin eyes. It is prohibited to release oil onto the ground or into watercourses.

- If repairs or modifications require welding work, you must first contact your dealer, who will provide you with the necessary welding instructions. Incorrect welding or ignorance during welding can result in sudden breaks in the structure.
- During loading and transport on public roads follow the applicable traffic legislation.

## LOCATION OF THE LABELS ON THE PRODUCT

The BIGAB hooklift trailer is equipped with a range of signs and labels relating both the safety and information of the machine. Check that all the labels are in the correct positions and visible. If signs or labels peel off or get damaged, they must be replaced. For replacement labels contact to your dealer for a new set and guidance for positioning.

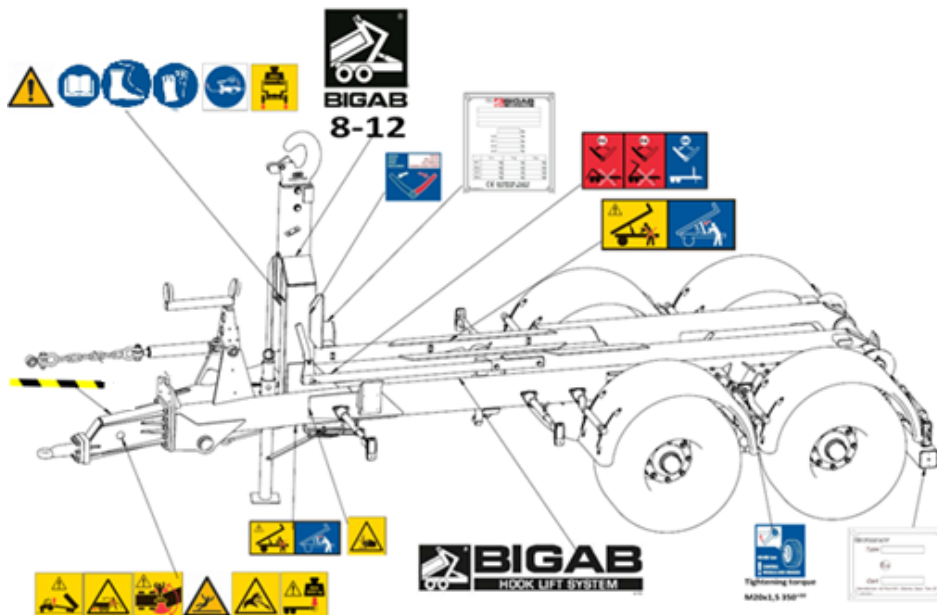

Location of the labels on the product

### Label set



#### **Warning and instruction manual**

Carefully read and comply with the instruction manual and work instructions. Read the instruction manual carefully before starting to use the trailer. Ignoring this can be potentially dangerous.



#### **Total weight**

It is absolutely prohibited to load more than the amount your model of trailer is designed to handle. This will be dangerous for you and your surroundings. Please check trailer specific total weight from the ID-plate.

Original Instruction



**Hazardous movement**

It is a hazardous movement if the rear end of the tractor lifts.

**Note!** This warning label is included in the delivery of your trailer. It must be attached in a clearly visible location in the tractor cab. If you would like more of these labels, they are available to order, free of charge, from our after sales department. Contact details are visible in the first chapter.



**Risk of injury**

It is absolutely forbidden to board the trailer when it is moving. Anyone doing so may be at risk of serious or fatal injury.



**Hazardous area**

Standing between the trailer and the towing vehicle when the trailer is being driven, moved with frame steering or when other functions are activated between the trailer and towing vehicle, can be potentially fatal. As the driver, you must always ensure that no one is in the area around the machinery.



**Risk of slipping**

There is a risk of slipping as the surfaces of the trailer can be slippery due to combination of oil/mud/rain on the surface. The ground around the trailer can also become slippery, as the tires can tear up the surface and expose mud and soil.



**Hydraulic fluid under pressure**

Hot hydraulic fluid at high pressure levels can occur in the hydraulic system. Take care when connecting, disconnecting and replacing hoses.



**Maximum load to coupling device**

Ensure that you do not load in such a way that the load on the towing eye exceeds the permitted values.

**NB!** Check your permitted towing eye vertical load value from technical data and marked to the towing eye. The load is largely determined by the way the weight is distributed on the container bridge, and it is the user's responsibility to ensure that this is not exceeded.

Original Instruction



**Risk of crushing injuries**

There is a risk of clamping or crushing injuries during work and maintenance. Do not place your hands to the machine or any other moving part.



**Use the security post during all service operations**

It is absolutely forbidden to lean under a raised frame unless it is secured with the security post. Under no circumstances may the trailer be carrying either a load or a container when using the security post.



**Labels for the use of safety equipment**

Use appropriate safety equipment in order to avoid injury when using the trailer.



**Lubrication**

This label used to show the importance of regular lubrication of the trailer. Lubrication points and schedule can be found in the chapter on lubrication.



**Tire inspection**

The tire bolts must be tightened and the brakes must be inspected and adjusted regularly.

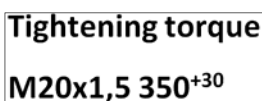

**Wheel bolts tightening**

This label indicates wheel bolts/nuts tightening torque.



**Exchange unit**

The exchange unit may not be operated unless the frame is folded down. During transport with the trailer, the hook must be folded down in the parking position.



**Tipping**

Lever must be pushed correctly to the extreme position, otherwise it might damage the trailer.

*Original Instruction*



**BIGAB hook trailer ID plate**

ID plate contains trailer specific technical data. This plate can be country specific.

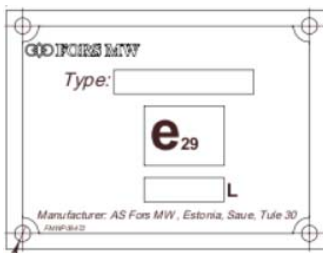

**RUP type approval plate**

If your trailer is equipped with type approved RUP, it is labelled with type approval plate that contains RUP specific type approval data.

**OPERATION**

**CONTROLS AND DISPLAYS**

The BIGAB hooklift trailer is only intended to be used and operated from the tractors' driver seat through the tractor hydraulic lever. Always adapt your operations to your level of experience, current load and road conditions. Do not exceed the trailers maximum travel speed and maximum loading values.

**NOTE:** If damage should occur during use, the work must be stopped immediately. The fault should be identified and eliminated before starting to use the trailer again.

**NOTE:** It is recommended to place load symmetrically. Always be sure that the container is firmly fixed before driving. Long container needs enough working space and turning area. Never make sharp turns at high travel speed.

Don't forget to lift the parking leg up before driving.

**UNLOADING TRAILER**

When unloading (loading) the trailer from the transportation platform the general principles of workplace rules for health and safety shall be complied. The hooklift trailer is firmly attached to the transportation platform with straps and chains. Wheels are secured by wedges or other objects without sharp edges to avoid rolling.

Before starting up, check visually that the trailer is not damaged during transportation. If the trailer is damaged, inform the company that transported the trailer and the dealer or manufacturer of the product immediately (follow CMR).

- Ensure that you have enough space for unloading the product. Wear personal protective equipment such as helmet and footwear. Lifting operator must be certified.
- Be careful when unloading and unpacking the trailer: do not damage sensitive components, do not change factory settings or damage paint or other surface finishes.

Original Instruction

Be careful when lifting so that cables, connectors or other components are not damaged for instance between lift fork and trailer frame.

- Lift up the trailer from transportation frame. See lifting points below. Weight depends on the type of trailer (see chapter Technical information);
- Lower the trailer to the ground.
- Usage of the trailer is strictly forbidden if safety devices of the trailer are damaged. For more detailed information about safety advice see the chapter on Safety Regulations.

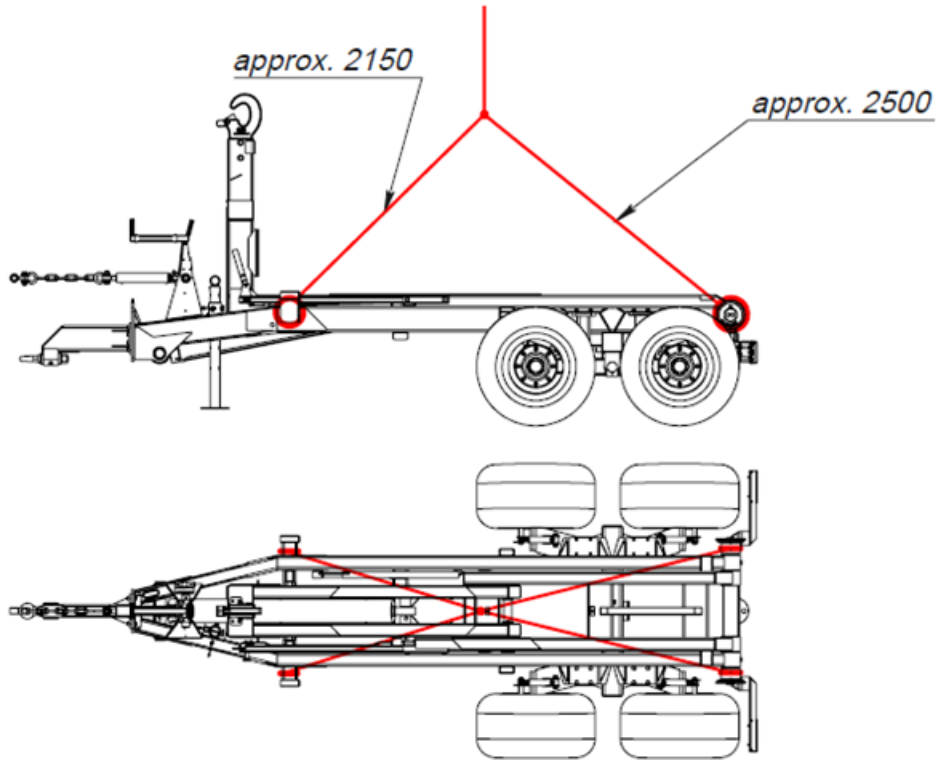

Lifting points for (un)loading

**BEFORE OPERATION**

A pre-operation checklist is provided for the operator for careful examination of trailer to ensure safe use of the trailer.

Before operating the machine and each time thereafter, the following areas should be checked:

Pre-operation checkpoint	OK/NOK
Check that personal protection equipment is used and is in good condition.	
Check and lubricate the machine per the schedule ( see Maintenance Section)	
Check that all bolts, nuts and hoses are connected tightly	
Check the towing eyelet for defects	
Check that the trailer is s securely and appropriately fixed to the towing vehicle	
Check condition of all hydraulic components. Replace if needed	
Check that all hydraulic functions are working	

Control the lights	
Check that brakes are functioning	
Verify that the hook is the right height to suit the container	
Check if there is enough working space and turning area	
Check the condition of the tires and air pressure.	
Check that the wheel nuts are tightened.	

### CONNECTING MACHINE

**Note:** When connecting and disconnecting the BIGAB, bear in mind the risk of clamping injuries, the risk of slipping, the tipping risk and the risk of hydraulic high-pressure jets and hot oil. Ensure that neither the hydraulic pump nor the power take-off is connected.

- Check that the towing eyelets' lock is undamaged and properly tightened.
- Connect the trailer's towing eyelet to the towing vehicle's tow hook. Ensure that the towing device is properly locked.
- Connect the frame lock.
- Before driving, parking leg must be lifted up and fixed with the pin.

**Note:** Parking brake is only for parking. Not for use during tipping, hooking or loading.

### Brakes

- Connect the hoses to the tractor's brake outlet.

### Travel lights

- Connect the light connector to the tractor's trailer outlet (12V or 24V).

### Hydraulic system connections

- Always check that the quick couplings are clean and that they lock properly.
- If trailer is equipped with electronic control system, supply voltage must be observed according to trailer options.

### HANDLING IN ROLL ON - ROLL OFF

**Exchange and tipping must be operated from the operator's seat in the towing vehicle!** If your BIGAB is equipped with suspension there is no bogie blocking.

**Ensure that the trailer is straight in front of the load!**

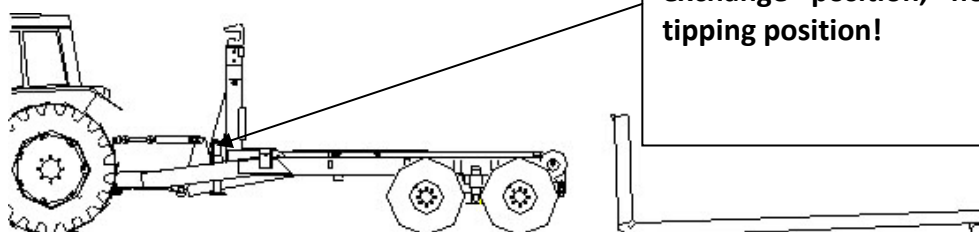

**On-loading!**

- Check that the load carrier is within the discs. Release the brakes on both the towing vehicle and the trailer to make it easier to roll on the load. Check the position of the tower during on-loading, so that the container frame does not catch on to the rollers from behind.
- The tower must be completely retracted when rolling on the container bridge in order to increase lifting force and reduce the strain on the coupling device. Ensure that the container frame does not catch in the rollers at the back of the trailer. Adjust the tower outwards continually during exchange in order to move clear past the rollers. If the tower is not adjusted upwards during on-loading, there is a considerable risk of the exchange's lock being damaged if the container frame catches in the rollers.



**Stop if the tractor lifts off the ground!**

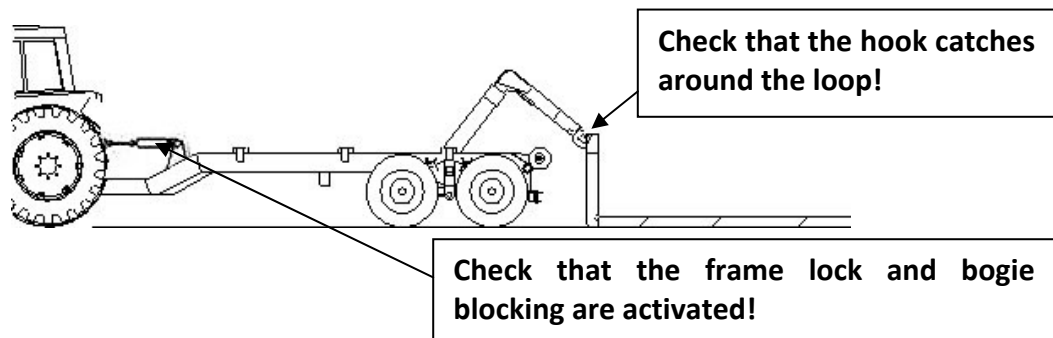

**Follow the movement with the extendable tower so that the front of the hooklift trailer's frame does not catch on to the rollers. When you have passed the rollers, always keep the hooklift trailer's frame close to the rollers.**

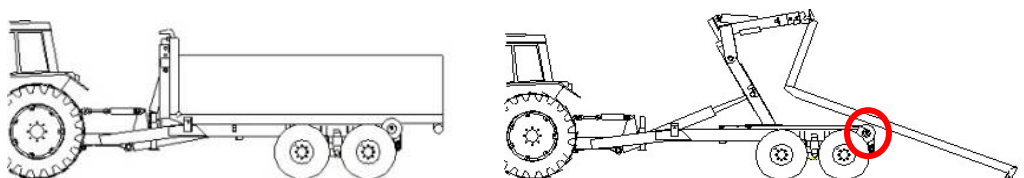

**Off-loading!**

Release the brakes on both the towing vehicle and the trailer to make it easier to roll off the load. Check the position of the tower during off-loading so that the container frame does not catch on the rollers from above.

- Lock the frame and activate bogie blocking between the towing vehicle and trailer.

Original Instruction

- Raise the hook lift frame slightly so that the container bridge does not scratch against the frame when you slide it backwards
- Then retract the tower backwards so that the locking rails/wings on the container bridge frame move freely and cannot be damaged.
- Adjust the tower upwards continually so that the container frame does not catch on the rollers at the back of the trailer during off-loading.
- If the tower is not adjusted during off-loading, there is a considerable risk of the exchange's lock being damaged if the container frame catches in the rollers.

## HANDLING IN TIPPING



Ensure that the towing vehicle and the trailer are securely coupled before tipping!

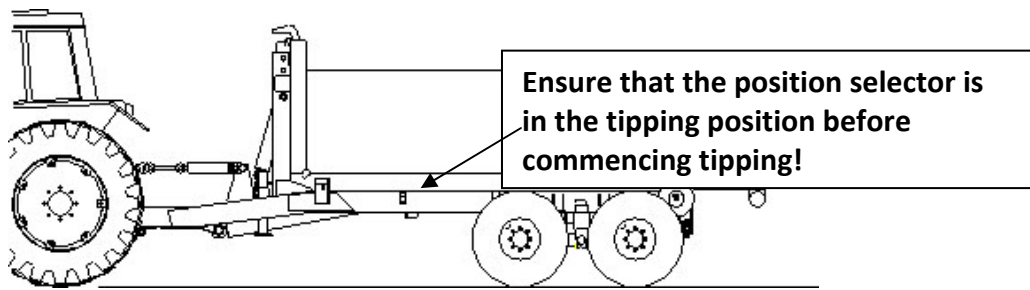

At maximum load, the telescope must be retracted 40 cm (400 mm) in order for the maximum load to be able to be tipped.

Place the hooklift trailer on a flat surface. **The sideways incline may not exceed 5 degrees!**

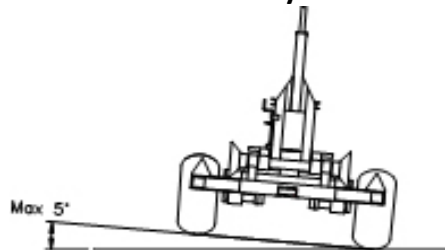

At maximum tipping angle – drive slowly forwards until the container is empty. Lower the container before continuing to drive.

**NOTE:** Ensure that the container bridge is locked in the correct position before driving.



**BIGAB**  
HOOK LIFT SYSTEM

**BIGAB 7-10, 8-12, 10-14, 12-15, 14-17  
10-14 G2, 12-15 G2**

Original Instruction

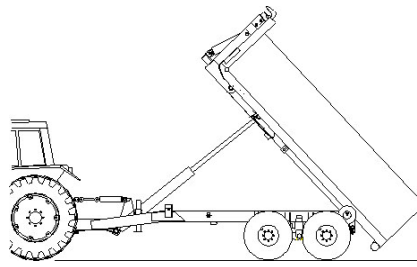

**When tipping, use the brakes to ensure that the machine does not roll away when the load slides off.**

## OPERATION WHEN DRIVING



**It is the responsibility of the user to ensure that a sufficiently powerful and heavy towing vehicle is coupled to the trailer in all situations. The use of a towing vehicle that is too small and insufficiently powerful can entail risks for the user and the environment, as well as leading to damage to the vehicle and trailer**

Table 1. Example of weight of different types of load

Load, kg	Kg/m <sup>3</sup>	Full container 7 m <sup>3</sup>	14 m <sup>3</sup>	21 m <sup>3</sup>	27 m <sup>3</sup>
Peas, Wheat, water content 15%	800	5.600 kg	11.200	16.800	21.600
Rye, water content 15%	750	5.250 kg	10.500	15.750	20.250
Barley, water content 15%	680	4.760 kg	9.520	14.280	18.360
Oats, water content 15%	560	3.920 kg	7.840	11.760	15.120
Silage, newly harvested	850	5.950 kg	11.900	17.850	22.950
Macadam	1 400	9.800 kg	19.600	29.400	37.800
Gravel	1 550	10.850 kg	21.700	32.550	41.850
Clay	1 800	12.600 kg	25.200	37.800	48.600
Wood chips (50% moisture content)	350	2.450 kg	4.900	7.350	9.450

*\*The higher the moisture content of the load, the heavier the load, a fact that the user has to take into consideration. This table is only an approximate estimate of the weights that can occur, and it is the responsibility of the user to ensure that the vehicle's limits and the applicable legislation are not being exceeded. The specified values are not exact values, just examples.*

For information purposes and for examples of how the weight of different loads may vary, please refer to the above table. This table should only be viewed as guidance and information. The manufacturer cannot be held responsible for dimensions or volumes specified in the table, and the table may only be viewed as a recommendation.

## Changing operating function

Figure below shows the lever for manually changing between the operating functions. The lever is located on the left side of the chassis. This operating function is also available with hydraulic drive.

Original Instruction

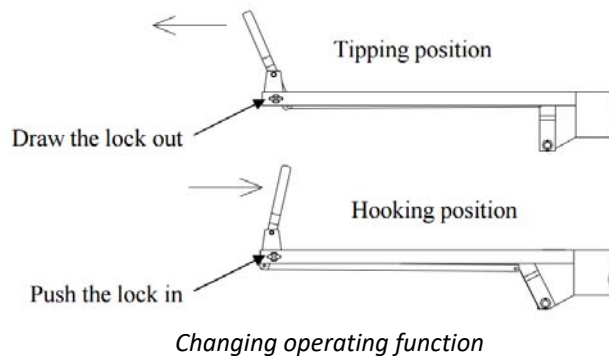

**NOTE!** The bolt needs to be locked within the handles extreme position.



**NOTE!** It is not allowed to change the changing unit unless the frame is in locked position.

### WORKING IN EXTREME CONDITIONS

Recommended working temperature range for a Bigab trailer from  $-30^{\circ}\text{C}$  up to  $+40^{\circ}\text{C}$ . Note that working at low temperatures accelerates hydraulic gaskets wear and increases hydraulic hoses exposure to damages and steel constructions exposure to brittle fracture. When working at lower temperature than recommended, lift lighter loads than usual.

Before starting to work in cold conditions let the oil circulate freely through the system a few minutes. Slowly work every hydraulic function through several times so that gaskets become flexible before they receive full pressure.

At exceptionally warm conditions beware of hydraulic oils excessive heating. Too high oil temperature (above  $+80^{\circ}\text{C}$ ) degrades the oil and can damages gaskets.

### ACTING IN DANGEROUS SITUATIONS



**If the trailer comes into contact with high voltage electric wires comply with the following instructions:**

#### ***If you are outside the machine***

Do not attempt to get into the machine. Keep everybody away from the machines vicinity. Do not touch any part of the machine.

Original Instruction

### ***If you are inside the machine***

Get out of it by JUMPING. Avoid touching any conducting parts. Do not make yourself a wire through which electricity may flow. Get away from the machine by JUMPING so that both feet do not touch the ground at the same time. The electrical field of the ground can cause electrocution if both legs are touching simultaneously (closing the circuit). You should be safe 20 meters away but this is of course a question of circumstances.

## **DISCONNECTING THE TRAILER**



**The oil can be very hot! Do not allow the hydraulic hoses to hang down to the ground**

- Park the trailer on a flat, stable surface. Position a parking leg.
- Switch off the tractor's hydraulic pump and power take-off. Release the remaining hydraulic pressure.
- Disconnect the hydraulic hoses. Start with the pressure line first, followed by the return lines and finally any electrical contacts. Ensure that protective plugs are installed in the hose.
- Finish by disconnecting the trailer's coupling device from the towing vehicle's tow hook.

## **CLEARING BLOCKAGES AND CLEANING**

- When cleaning, first perform a rough cleanse using just water. Avoid using high-pressure sprays on electrical components;
- Use an environmentally friendly detergent. Allow it to work for the specified time. Rinse off with hot water;
- Always lubricate the BIGAB after cleaning.

## **TRANSPORT**

The hooklift trailer is meant to be transported attached to the tractor at maximum design speed.

- Ensure that none of the additional equipment connected to the trailer can cause accidents during transport;
- You must always maintain control of the unit in all situations;
- Always check that the LGV sign and reflective signs are in the correct locations;
- The permitted transport dimensions, must never be exceeded;
- Before driving, check that no one is in the vicinity of the machine and that your visibility is unrestricted;
- Bear in mind the height of the machine when driving under flyovers;
- Traffic rules are there to be followed - comply with the applicable legislation.

**NOTE:** Observe the specified safety distance to electrical cables when you are in the vicinity of such cables.

## MAINTENANCE

- Make sure that the trailer is standing on a flat surface;
- Make sure that the trailer can't move;
- When lubricating or servicing the trailer, turn off the vehicle engine;
- Be sure that the trailer can't slip when using support leg, jack or similar equipment;
- Always use the security post in tipping position when servicing. The security post must always be used when carrying out service work in the tipped position. There must not be any load on the trailer when carrying out service work in the tipped position (see figures below);
- Never attempt to do maintenance work on the hydraulic system before you are sure there is no pressure;
- Do not tighten or repair leaking hydraulic couplings while the system is pressurized;
- Never attempt to localize a leakage from hoses or connections by feeling with your hand. The high-pressure oil jet blaze can penetrate skin and cause serious burns and damages. High-pressure oil is also highly flammable;
- Avoid getting oil into eyes. Use safety goggles and gloves. If eyes are exposed to oil, flush them with cool water and immediately contact a doctor.



**It is strictly forbidden to lean underneath the container without using the security post!**

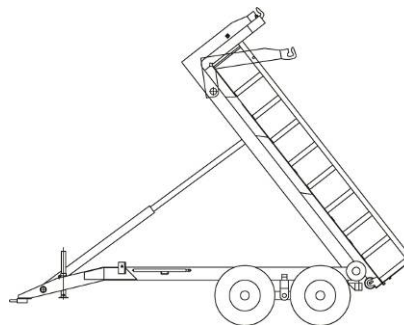

*Raised container bridge*



*Use of security post*

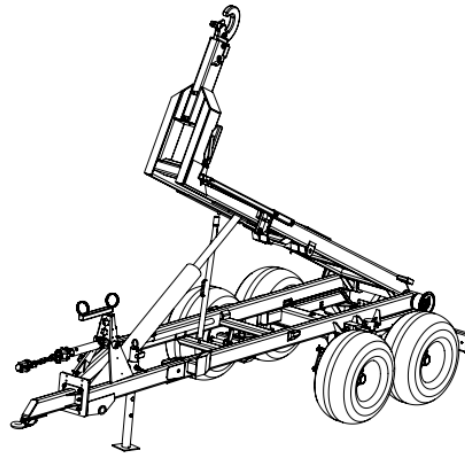

*Security post position*

Service and maintenance must be carried out regularly in order to guarantee problem-free, economical use.

**NOTE:** Failure to comply with the Fors MW instruction manual invalidates all the machine's guarantees. Regular, correct maintenance is a precondition for the guarantees applying.

**NOTE:** Only genuine spare parts may be used during repair and maintenance work.

### **DAILY/MONTHLY/YEARLY MAINTENANCE PROCEDURES AND INSPECTION**

All kinds of maintenance work are subdivided into two groups: operating (preventive) and compulsory (scheduled). The need for operating maintenance is determined based on the results of checking the equipment.

#### ***General:***

- Maintenance works must be carried out regularly to ensure safe and malfunction-free operations;
- Maintenance works does not require any special tools. The user can perform most of the operations;
- Use correct tools;
- Attempt to localize the defects as precisely as possible; you should try to avoid opening the system unnecessarily;
- Keep disassembled parts and repair area free from dirt;
- Keep spare parts in their packages until needed for installation;
- Valve adjustments and repairs are recommended to be handled by trained service personnel.

#### ***Daily inspections:***

- Examine the trailer visually. Note defects and failures that might affect safety. Repair possible defects and failures. Look extra carefully at the position of the Towing eyelet;
- Check so there is no leakages from the hydraulic system, or damaged hoses;
- Work through every function to its extreme position;

*Original Instruction*

- Check the tires and brakes;
- Check that all bolts, nuts and hoses are connected tightly;
- Check the oil level if trailer is equipped with pump and oil tank set;
- The towing eyelet must be controlled for excessive wear and tear every time before the trailer is used. The towing eyelet needs to be changed at least once a year under normal operation conditions. It is up to the user of the trailer to ensure that this is done.

***Weekly maintenance:***

- Tightening of the main cylinder bolts;
- Clean the trailer regularly with sponge and soap;
- When cleaning never use hot water under high pressure, it will remove the grease from bearings;
- Check the operation of the device;
- Check hydraulic pressure;
- Check the brake condition;
- Check wheel nut tightness;
- Check the bolts connecting the drawbar;
- Check the lights, reflectors and lamps.

***Monthly maintenance:***

- Check the air pressure in tires;
- Check if there is enough lubricant on glide surfaces;
- Clean and lubricate hydraulic cylinders;
- Check hydraulic hoses for damages.

***Yearly maintenance:***

The towing eyelet needs to be changed at least once a year under normal operating conditions. It is up to the user of the trailer to ensure that this is done.

***Maintenance of the hydraulic units:***

- Clean and lubricate piston rods of hydraulic cylinders;
- Check the hydraulic valves: Visually check the hydraulic valves. In case of leaking replace the damaged valve;
- Check hydraulic hoses: Visually check the hydraulic hoses and pipe connections. Replace a hose in case of leaking or if there are ruptures or slashes on it;
- Check the oil level, add and replace oil if trailer is equipped with pump and oil tank set. If not then please check tractor oil level;
- Check the operation of the device;

When replacing hydraulic components such as hoses, gaskets etc, make sure they correspond with original parts. To avoid malfunctions and ensure safe operation use original spare parts.

***Changing the seals***

Change all the cylinder seals at the same time. The piston cannot be split. The seals must be slipped over the piston edge. Be careful not to break the seals when fitting them in place!

Original Instruction

- After removing the old seals clean the grooves carefully before fitting the new seals into place;
- Lubricate the new seals with hydraulic oil;
- Open the pistons lock nut;
- Screw the piston off;
- Withdraw the guide piece from the rod;
- Change the guide piece seals; make sure that the piston rod seal is in the right position, i.e. the lip against the pressure.



**Never operate the hydraulic system when the oil drops below the lower level mark!**

### ***Maintenance of the pneumatic units***

It is important to inspect pneumatic components to avoid leakage of compressed air. Nominal pressure of the system is marked in the technical data section of the hooklift.

- Clean and lubricate piston rods of pneumatic cylinders;
- Emptying the water collector: Condensed water is removed from the air tank located in the side of trailer via water release valve;
- Check the pneumatic valves: Check the pneumatic valves by listening to the working sound. In case of leaking replace the damaged valve;
- Check pneumatic hoses: Check visually pneumatic hoses and union pipe connections. Replace a hose if there are ruptures or slashes on it;
- Check the operation of the device.

### ***Maintenance of the electrical components***

The trailer is manufactured with 12V electrical system. Electrical system is shown in chapter Electrical and hydraulic systems. The wires to the electrical equipment are of different colours, which facilitate the location of the wire leads connecting individual items of the electrical equipment. Refer to the electrical diagram to ensure a correct subsequent reconnection of the electrical units and also when checking the operation of the equipments and individual electric circuits.

- Clean and check the lights: In case of fault replace the bulb. If the bulb keeps on breaking repeatedly, find out the cause, for LED lights replace the full light set;
- Check electrical connectors;  
Clean them of dirt and dust;
- Check wires insulation: Check wire insulation, wire joints and protection against rubbing during and contacting the trailer parts. Protect the wires from oil and fuel, which ruin insulation. Wipe dirty wires.



**Join and disjoin plug connectors only with dead circuits!**

### **Maintenance of the brake system**

- Control the brakes regularly. Test the brakes at least once per week while trailer is working.
- See to it that no lubricant penetrates into the brakes. Any lubricant, which has penetrated the brake, causes greasing of the disks, thereby reducing friction between their working surfaces. A poor operation of the brakes is the result of such a situation. In such a case dismantle the brake, eliminate the oil leakage, wash the greasy disks with a cleaner or gasoline and let them dry out.
- Always control the brake control linkage after the drum has being dismantled, adjust if needed. For adjusting the brakes you need to lift up the bogie-frame from the ground and adjust the brake levers. You do this by spinning the wheel while adjusting. The brakes are correctly adjusted when they spin freely without any scraping noises from the wheel.
- After any kind of adjustment of the all kinds of the brakes, always carry out a practical brake test before driving away.
- If the brakes seems to work poor, apply the brakes, pull the trailer maintaining low speed for a couple of hundred meters, try again braking the vehicle while driving at a normal speed. Repeat until the brakes functions normally. If this doesn't help, it is necessary to contact your dealer or our service department!

### **Maintenance of wheels**

When working on the tires, parking shoes or other objects without sharp edges must be placed under the wheels of the trailer to prevent it from rolling.

Replacement or repair of the wheel must be carried out by a trained person and with appropriate tools.

The wheel can be taken off only when the trailer is unloaded.

A check must be carried out after the first use, after the first work with a load, after a whole day of intensive work and every 6 month or when the trailer has not been used for a longer period. The checks shall be repeated after every removal of the wheel from the axle.

- Place the hooklift trailer on a flat surface. **The sideways incline may not exceed 5 degrees!**

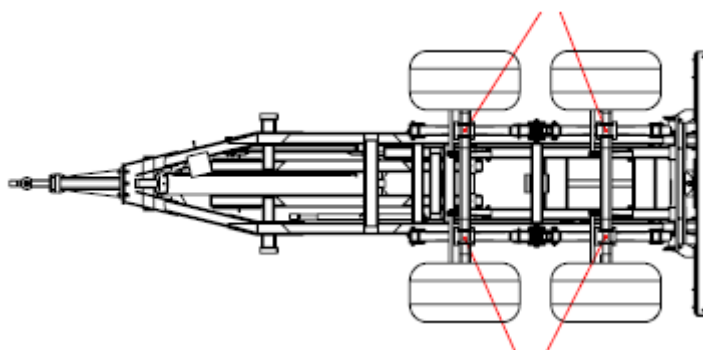

*Sprung pendulum bogie suspension and suspension tandem parabolic jacking points*



Original Instruction

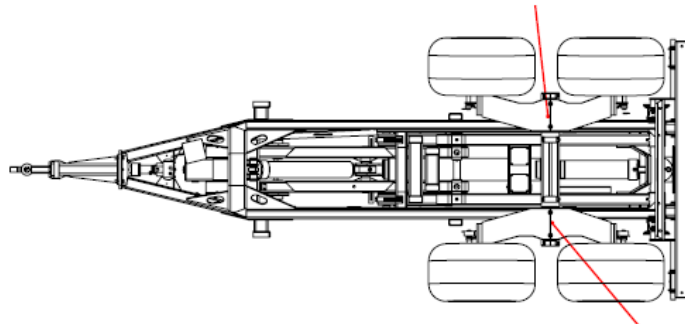

*Mechanical pendulum bogie jacking points (bogie block must be installed)*

- Check the wheel nuts. Insure that wheel nuts are in place and that they are tightened according to the chapter on Tightening torque;
- Check the air pressure in the tires. Please note that high temperature could raise tire pressure and reduce load or speed required. In that case do not release air out from tires because tires will get underinflated after temperature returns to normal. Over inflation could cause burst of tire.
- For suitable wheel sizes and air pressure see chapter for Technical information.
- Tires must be disposed at authorized location.

Do not exceed trailers maximum design speed or maximum load. Avoid holes, sudden manoeuvres or high speeds when turning.

***Maintenance undercarriage***

**Every day** - It is necessary to visually check the nuts on the undercarriage each time the customer uses the trailer. If the axel for the bogie side is at all moving the trailer is in **DANGER**. Stop at once and tighten the bolts as shown in pictures below.

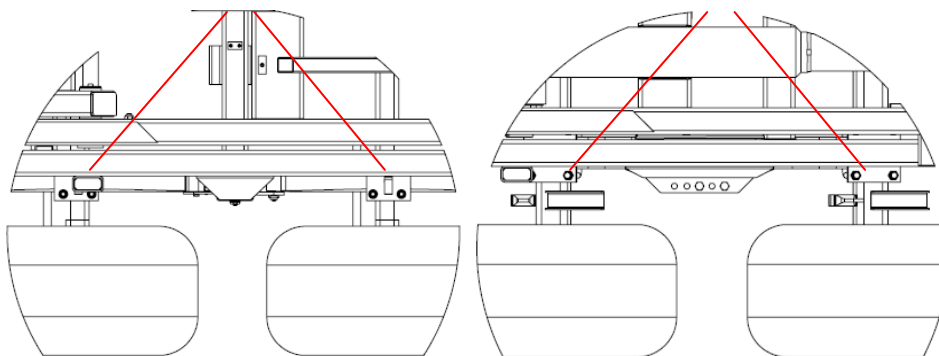

*BIGAB tandem parabolic bolts tightening*

*BIGAB sprung pendulum bolts tightening*

**MAINTENANCE MATERIALS**

**NOTE:** When changing oil, collect the oil in a safe manner. Never release oil onto the ground. This is prohibited by law. Oil and grease must, by law, also be disposed of at an authorized location.

Table 2. Recommended lubricants

Brand	Type
BP	Energrease LS-EP2, L2M
ESSO	Beacon EP2, Multipurpose GR Moly
MOBIL	Mobilux EP2, Mobil Grease MP Special
SHELL	Alvania EP Grease 2
UNION/TEXACO	Marfak Multi-Purpose 2, Molytex Grease 2

Recommended hydraulic oils: UTTO or STOU SAE10W/30, SAE 32, SAE 46.

**NOTE:** Use only hydraulic fluids recommended for your tractor hydraulic system by the manufacturer.

### TIGHTENING TORQUES

The tightening torque (Mv) in Nm for untreated, oiled steel screw joints when using a torque wrench or screwdriver/wrench with torque control. Torque range max.  $\pm$  5%. Metric coarse threads. All bolts must be tightened after 10 hours of operation.

Table 3. Tightening torques

Thread M	Property class according to ISO 898/1		
	8.8	10.9	12.9
5	5.7	8.1	9.7
6	9.8	14	17
8	24	33	40
10	47	65	79
12	81	114	136
14	128	181	217
16	197	277	333
18	275	386	463
20	385	541	649
22	518	728	874
24	665	935	1120

## LUBRICATION SCHEDULE

Recommended lubrication cycle is once per week or after 20 working hours. Lubricate points equipped with grease nipples by using a grease gun. Use recommended lubricants.

- Ensure regularity of lubrication by following the lubricating schedule.
- Keep flammable material away from heat, sparks and open fire.
- Do not allow oil to spill on the ground as it will cause environmental pollution.

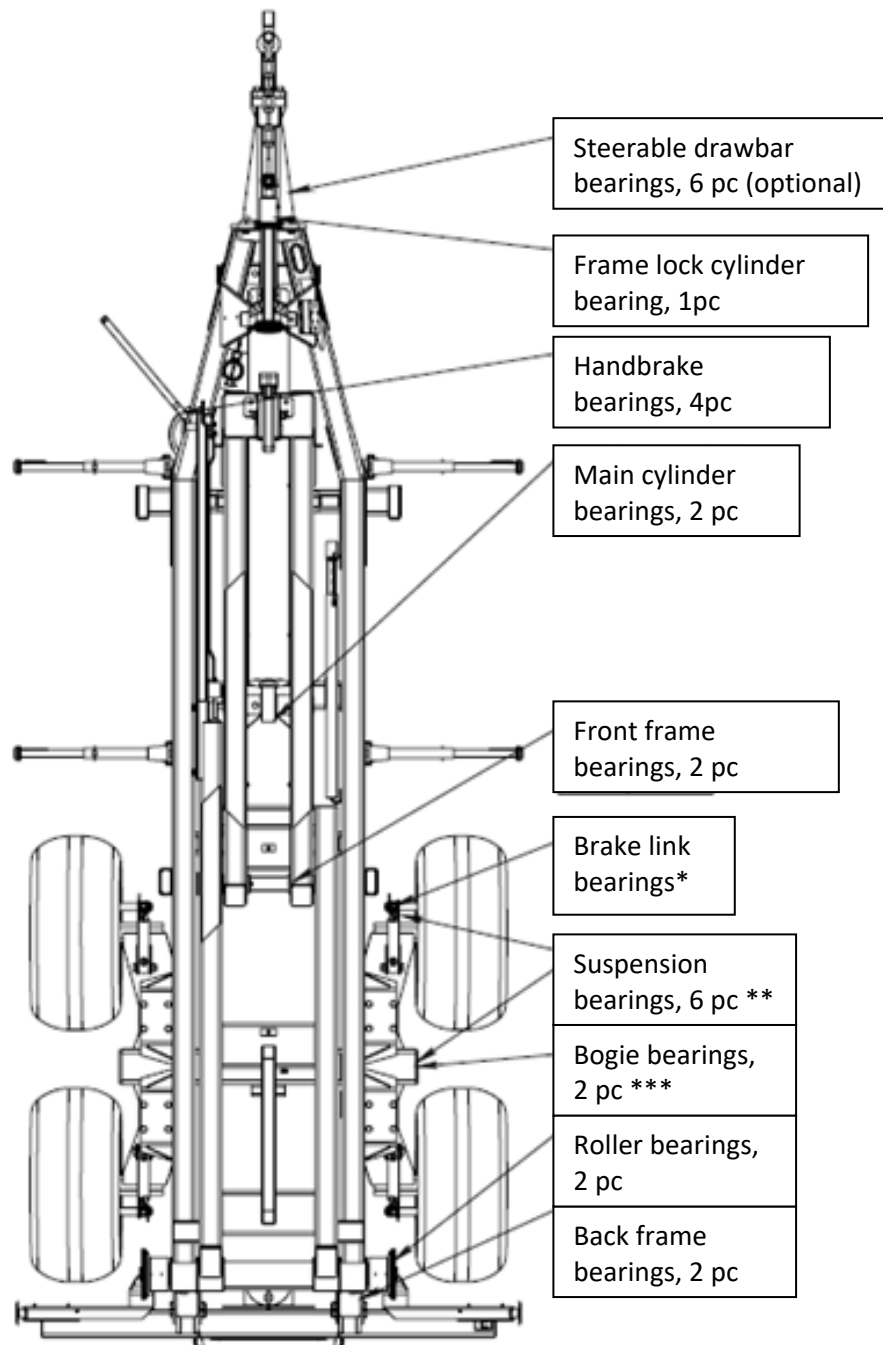

Figure 1. Lubrication points of BIGAB

\* 4 pcs for tandem suspension, 8 pcs for mechanical pendulum bogie, 12 pcs for sprung pendulum bogie

\*\*Only for tandem suspension

\*\*\*Only for mechanical pendulum bogie

## STORAGE

If the trailer is not going to be used for an extended period (longer than 2 months) of time, it is important to clean it carefully. Note that high-pressure washing is not recommended. After washing, all the lubricating points must immediately be lubricated. Lubricating with new grease forces the water away from surfaces and thereby counteracts corrosion and wear. It is not allowed to store the trailer in a cold and/or damp environment for a long period.

- Store the trailer under a roof. If this is not possible, the trailer must be covered with a tarpaulin;
- Before lowering the trailer onto its storage surface, ensure that the surface will not give way during the storage period, for example due to rain or the thawing of frozen soil;
- Place the trailer in the transport position;
- Support the trailer to ensure it will not overturn during storage;
- Use wheel chokes to prevent the trailer from moving while stored.
- During longer periods of storage the trailer should be moved every 2 or 3 weeks to avoid deformation of tires and maintain proper geometry.
- Tire pressure should be inspected from time to time, and if necessary inflated.

**NOTE:** A trailer in storage is not a play area for children.

## CLEANING

Remove accumulated dust and dirt. Painted outer surfaces should be cleaned regularly with sponge and soap. When cleaning never use hot water under high pressure, it will remove the grease from bearings.

**NOTE:** Avoid high-pressure washing when cleaning. First clean simply with warm water. If necessary, use an environmentally friendly detergent. Lubricate the trailer after cleaning.

## TROUBLESHOOTING

These troubleshooting instructions are provided to help you to determine the cause for a malfunction.

*Table 4. Electrical equipment troubles*

Fault symptoms	Reason and action
Lights fault	Lamp burn out. Replace lamp.
	Check and clean electrical connectors.
	Check fuses.
Cable broken.	Check and repair the cable.

*Table 5. Hydraulic equipment troubles*

<b>Fault symptoms</b>	<b>Reason and action</b>
Will not return from working position to neutral.	Valve stuck. Clean valve parts. Valve should move freely without seizure.
Air in the hydraulic system.	Locate leaky point and eliminate defect. Check oil level.
Low oil pressure.	Adjust oil pressure.
Hydraulic cylinder piston sealing out of order or leaking.	Replace sealing.
Hydraulic system noise	Air in the system. Locate air suction and eliminate defect.
Distributor safety valve maladjusted.	Adjust valve only with trained service staff.
Oil leaking	Replace ruptured hose or tighten hose connection.
Oil leaks from electrical control valve.	Replace sealing
Lift is too slow	Check oil flow

*Table 6. Brake system troubles*

<b>Fault symptoms</b>	<b>Reason and action</b>
Poor operation of brakes	Greasy or worn-out brake pads. Wash brake drums or pads with cleaner or gasoline.
Poor brake efficiency	Adjust brake control linkage.

Original Instruction

## TECHNICAL INFORMATION

### DESIGN OF THE PRODUCT

The trailer is constructed out of cold hollow steel sections. Through this construction the trailer receives maximum endurance and stiffness regarding both bending as well as twisting. The trailer is steady both in the tip as well as in the changing movement. See main components, roll on-roll off positions and tipping position from figures below.

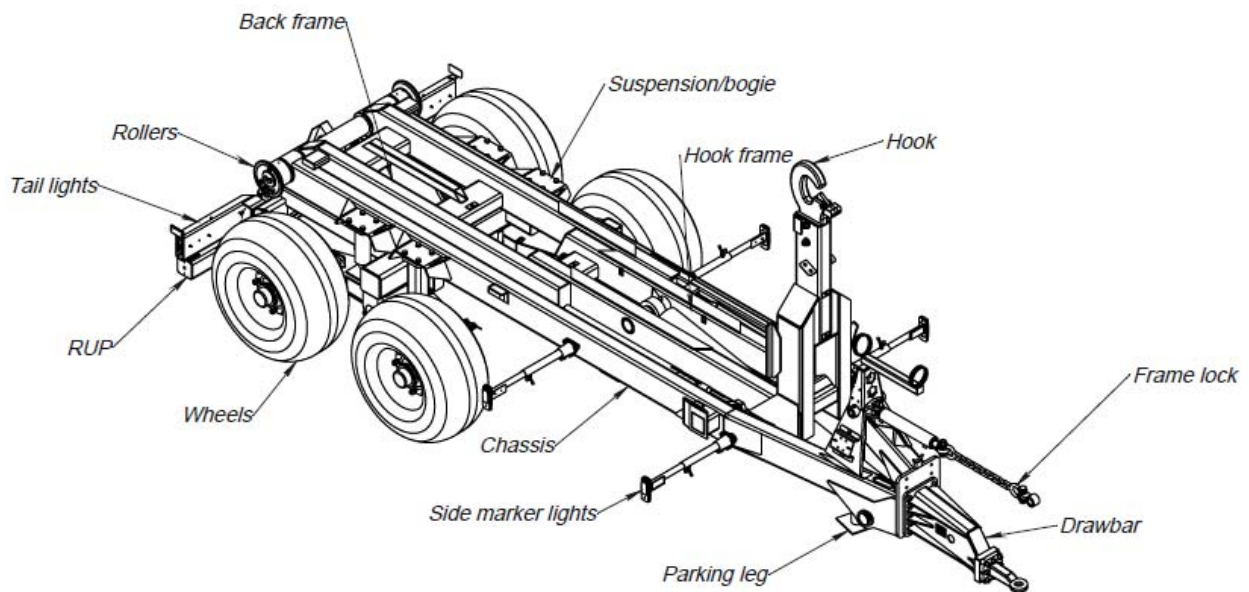

Main components of trailer

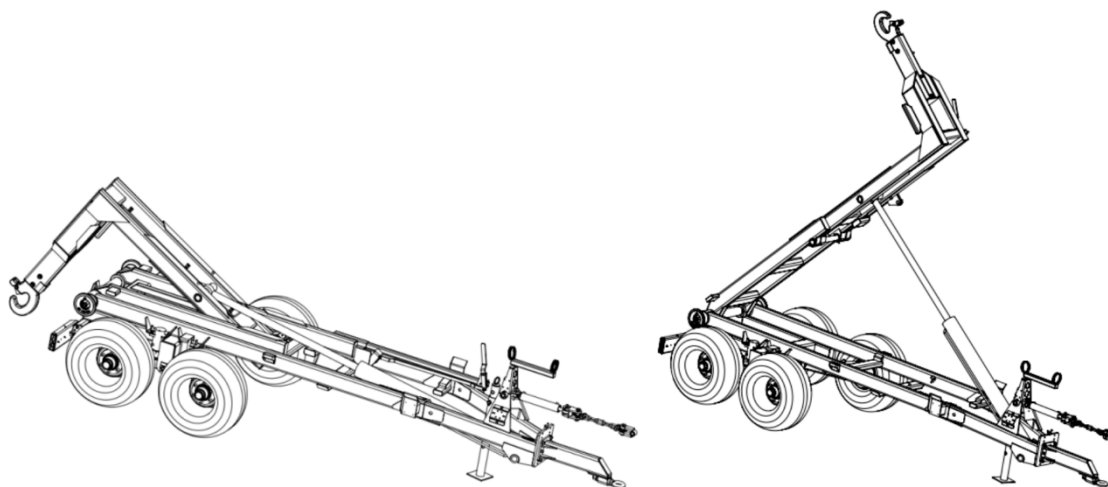

Roll on - roll off position 7-10

Tipping position 7-10

Original Instruction

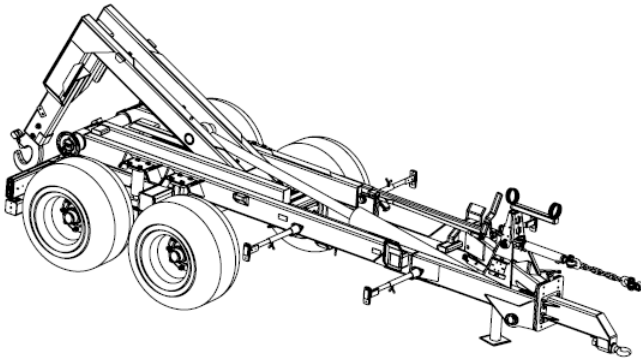

*Roll on - roll off position 8-12, 10-14, 12-15 and 14-17*

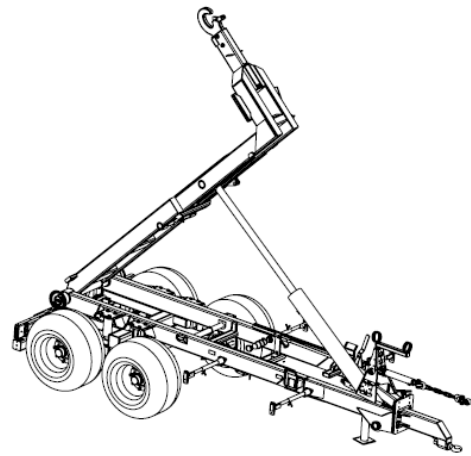

*Tipping position 8-12, 10-14, 12-15 and 14-17*

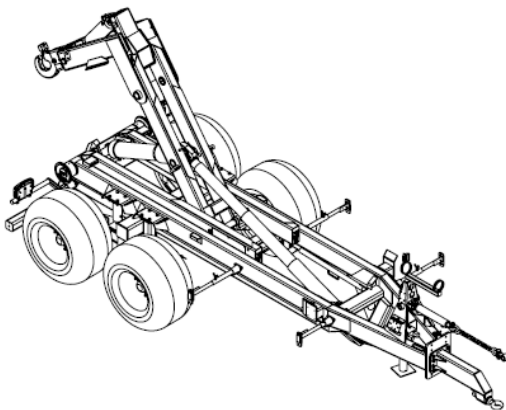

*Roll on - roll off position 10-14 G2 and 12-15 G2*

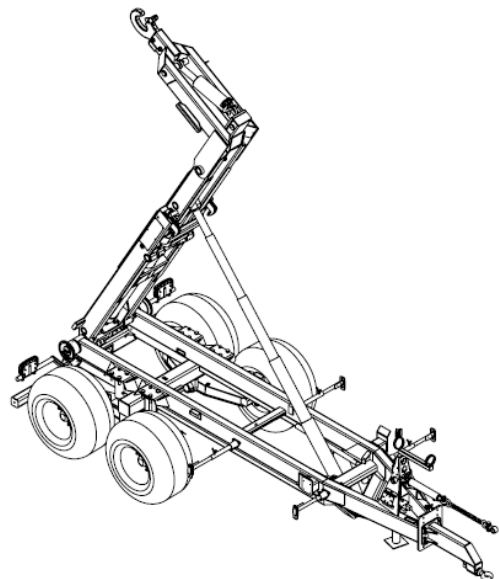

*Tipping position 10-14 G2 and 12-15 G2*

### Hook

The trailer is equipped with adjustable hook for three different standard container heights (see figure below).

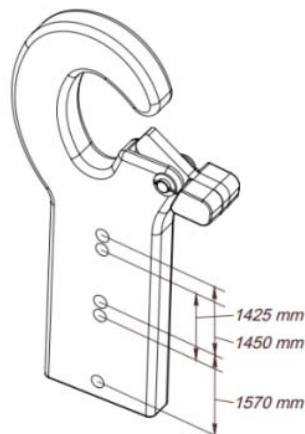

*Hook*

**Parking leg**

Parking leg is designed to be supporting when trailer is under maintenance or when trailer is not in use. Standard trailer is equipped with manual parking leg. Hydraulic leg is option.



**If trailer is at full load then it is not allowed to use parking leg!  
Before driving parking leg must be lifted up and fixed with the pin!**

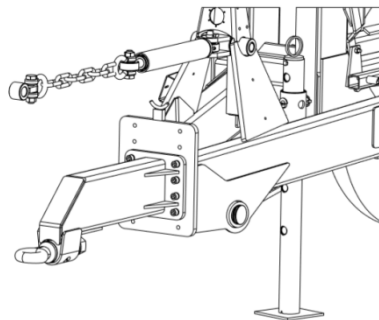

*Parking leg*

**Frame locking**

The hydraulic frame lock is used to lock the frame during the exchange function. The manometer is present to indicate the tensile force on the cylinder. Do not use the frame lock while driving.

- When connecting the frame lock, the cylinder must be completely out;
- Connect the frame lock chain to the tractor third point;
- Check that the frame lock is tighten enough;
- To make the frame lock tighten, shorten the chain;
- When the frame lock is on, the pressure gauge must not exceed 100 bar.

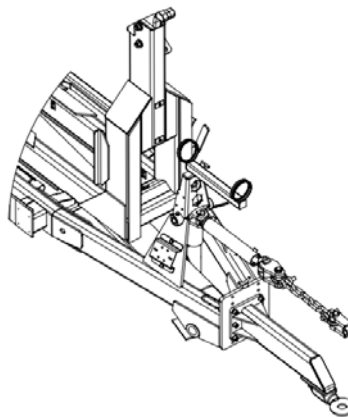

*Frame lock*

**Wheels**

The trailer could be equipped with wheels as listed in the table. Various alternatives (wheel types) are available - please ask from your dealer.

*Table 7. Wheels, speed limit 40 km/h*

Wheel type	Air pressure	7-10	8-12	10-14	10-14 G2	12-15	12-15 G2	14-17
19/45-17 (ET-70)	3,3*	x	X					

Original Instruction

400/60-15,5 (ET-15)	3,6*	x						
480/45-17 (ET-70)	5*	x	X					
500/50-17 (ET 0)	3,7*			X	X		X	
435/50-19,5 (ET 0)	9 *			X	X	X	X	X
500/50-17 (ET -35)	3,6*	x		X	X		X	
500/50-R17 (ET 0)	2,5 *			X	X	X	X	X
500/50-R17 (ET -70)	3,7*	x	x					
500/45-R22,5 (ET -70)	2,7*	x	x					

\* The air pressure might be different between different tire manufacturers. For exact air pressure we recommend taking contact with the tire manufacturer or check information on the tire.

## TECHNICAL DATA

Below are the technical specifications of standard trailers. Exact figures depend on the options you have purchased for your trailer. To get exact technical data for your trailer or if you have question, contact your dealer.

Maximum speed of the trailer is dependent on the trailer options and country of designation.

Hooklift trailer	7-10
Frame (hollow section)	160x80x8
Wheel dimension	19/45-17; 400/60-15,5; 480/45-17; 500/50-17
Requisite tractor hydraulics	1 break outlet; 2 double action
Electric system	12V
Oil volume ***	6
Trailer weight (kg)*	2000-2200 kg
Trailer length (mm)*	Min 5500 – Max 5800
Width across wheels (mm)*	2130
Total weight (kg)	10000
Max load including container (kg)	8000
Max load during container exchange (kg)	7000
Load on towing eye (kg)**	1200-2000
Max tipping capacity (kg)	8000
Max working pressure (Mpa)	17,0

Hooklift trailer	8-12
Frame (hollow section)	200x100x6
Wheel dimension	19/45-17; 480/45-17; 400/60-15,5

*Original Instruction*

Requisite tractor hydraulics	1 break outlet; 2 double action
Electric system	12V
Oil volume ***	8
Trailer weight (kg)*	2200-2400 kg
Trailer length (mm)*	Min 5790 – Max 6400
Width across wheels (mm)*	2100
Total weight (kg)	12150
Max load including container (kg)	10000
Max load during container exchange (kg)	8000
Load on towing eye (kg)**	1500-2000
Max tipping capacity (kg)	10000
Max working pressure (Mpa)	17,0

Hooklift trailer	10-14
Frame (hollow section)	200x100x6
Wheel dimension	435/50R-19,5; 500/50-17
Requisite tractor hydraulics	1 break outlet; 2 double action
Electric system	12V
Oil volume***	8
Trailer weight (kg)*	2300-2500 kg
Trailer length (mm)*	Min 5790- Max 6400
Width across wheels (mm)*	2300
Total weight (kg)	14300
Max load including container (kg)	12000
Max load during container exchange (kg)	10000
Load on towing eye (kg) **	1600-2300
Max tipping capacity (kg)	12000
Max working pressure (MPa)	22,0

Hooklift trailer	10-14 G2
Frame (hollow section)	200x100x6
Wheel dimension	435/50R-19,5; 500/50-17
Requisite tractor hydraulics	1 brake outlet, 3 double action
Electric system	12V

Original Instruction

Oil volume ***	23
Trailer weight (kg)*	2500-2700 kg
Trailer length (mm)*	Min 5790- Max 6400
Width across wheels (mm)*	2300
Total weight (kg)	14300
Max load including container (kg)	12000
Max load during container exchange (kg)	10000
Load on towing eye (kg)**	1600-2300
Max tipping capacity (kg)	11750
Max working pressure (MPa)	21,0

Hooklift trailer	12-15
Frame (hollow section)	200x100x6
Wheel dimension	435/50-19,5; 500/50-17
Requisite tractor hydraulics	1 brake outlet, 3 double action
Electric system	12V
Oil volume***	10
Trailer weight (kg)*	2500-2700
Trailer length (mm)*	Min 5790- Max 6400
Width across wheels (mm)*	2300
Total weight (kg)	14500
Max load including container (kg)	13000
Max load during container exchange (kg)	12000
Load on towing eye (kg)**	1600-2300
Max tipping capacity (kg)	13000
Max working pressure (MPa)	22,0

Hooklift trailer	12-15 G2
Frame (hollow section)	200x100x6
Wheel dimension	435/50-19,5; 500/50-17
Requisite tractor hydraulics	1 brake outlet, 4 double action
Electric system	12V
Oil volume***	27
Trailer weight (kg)*	2700-2900

Original Instruction

Trailer length (mm)*	Min 5790- Max 6400
Width across wheels (mm)*	2300
Total weight (kg)	14500
Max load including container (kg)	12000
Max load during container exchange (kg)	12000
Load on towing eye (kg)**	1600-2300
Max tipping capacity (kg)	12000
Max working pressure (MPa)	21,0

Hooklift trailer	14-17
Frame (hollow section)	200x100x6
Wheel dimension	435/50-19,5; 500/50-17
Requisite tractor hydraulics	1 brake outlet, Electric control valve, pressure and free return
Electric system	12V
Oil volume***	10
Trailer weight (kg)*	2800-3100 kg
Trailer length (mm)*	Min 5790- Max 6400
Width across wheels (mm)*	2400
Total weight (kg)	14500
Max load including container (kg)	14000
Max load during container exchange (kg)	14000
Load on towing eye (kg)**	1600-2500
Max tipping capacity (kg)	14000
Max working pressure (MPa)	22,0

\* Depending about equipment of the trailer

\*\* Depending in the position of the container and equipment of the trailer. Check your permitted towing eye vertical load value as marked to the towing eye.

\*\*\* Minimum available oil volume, with full system (L)

Original Instruction

**DIMENSIONAL DRAWING**

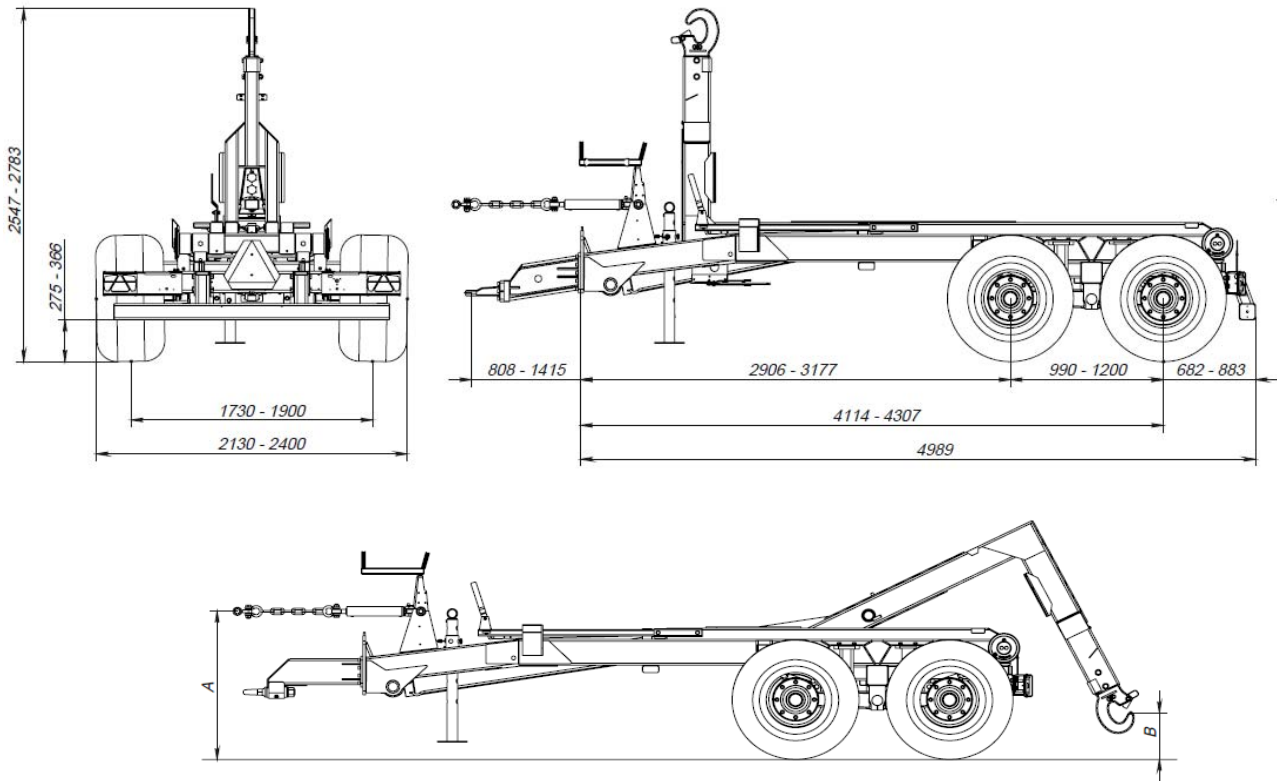

Dimension from ground surface to frame lock (A)

Model\ Suspension	Mechanical pendulum	Tandem suspension	Sprung suspension
7-10	1066	NA	NA
8-12	1130	1177	NA
10-14	1188	1245	1176
12-15	1188	1245	1176
14-17	NA	NA	1178
10-14 G2	1182	1239	1190
12-15 G2	1182	1239	1190

Dimension from ground surface to hook (B)

Model\ Suspension	Mechanical pendulum	Tandem suspension	Sprung suspension
7-10	394	NA	NA
8-12	332	379	NA
10-14	385	442	373
12-15	385	442	373
14-17	NA	NA	372
10-14 G2	1110	1167	1118
12-15 G2	1048/1600	1105/1600	1056/1551

\* The length of the trailer depends on drawbar. The height of the trailer depends on wheels.

More specific information about the trailer can be found in the spare parts catalogue.

Original Instruction

**ELECTRICAL AND HYDRAULICAL SYSTEM**

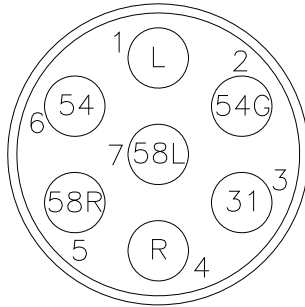

Electrical cable connection

**Electrical cable connection for rear lights with round 7 pin cable plug  
Colors according to ISO 1724**

Electrical cable connection.

No	Pos	Colour	Function
1	L	Yellow (YE)	Left turn signal
2	54G	Blue (BU)	Fog light
3	31	White (WH)	"-" Ground
4	R	Green (GN)	Right turn signal
5	58R	Brown (BN)	Right tail light/side marker
6	54	RED (RD)	Stop light
7	58L	Black (BK)	Left tail light/ side marker

Original Instruction

### Rear lights

The trailer is manufactured with 12V electrical system.

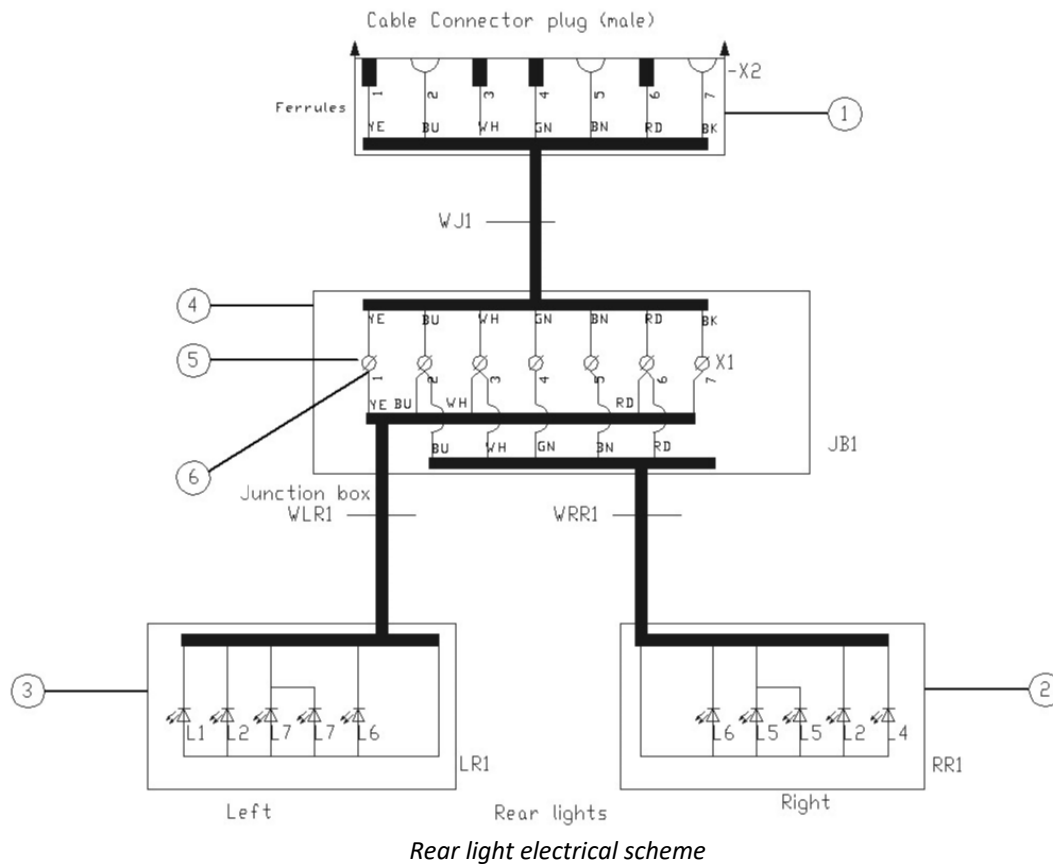

Table 8. Rear light electrical scheme main components

Pos	Description	Qty.
1	Cable set with plug	1
2	Right rear lights	1
3	Left rear lights	1
4	Connection box	1
5	Terminal strips 10mm <sup>2</sup>	1
6	Ferrule	10

Original Instruction

### License plate lights

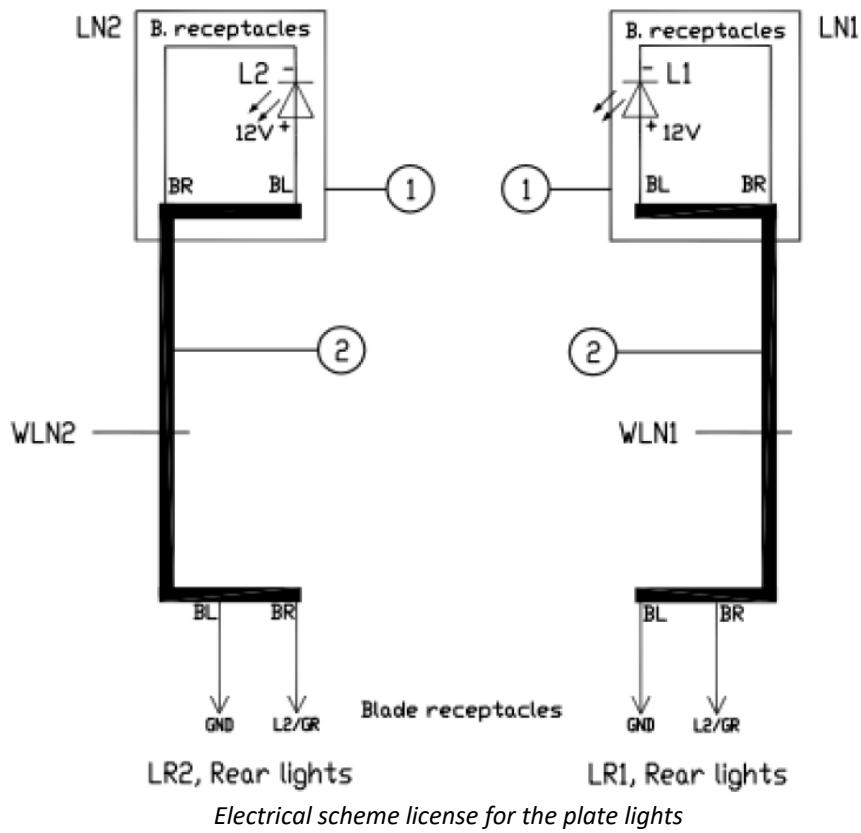
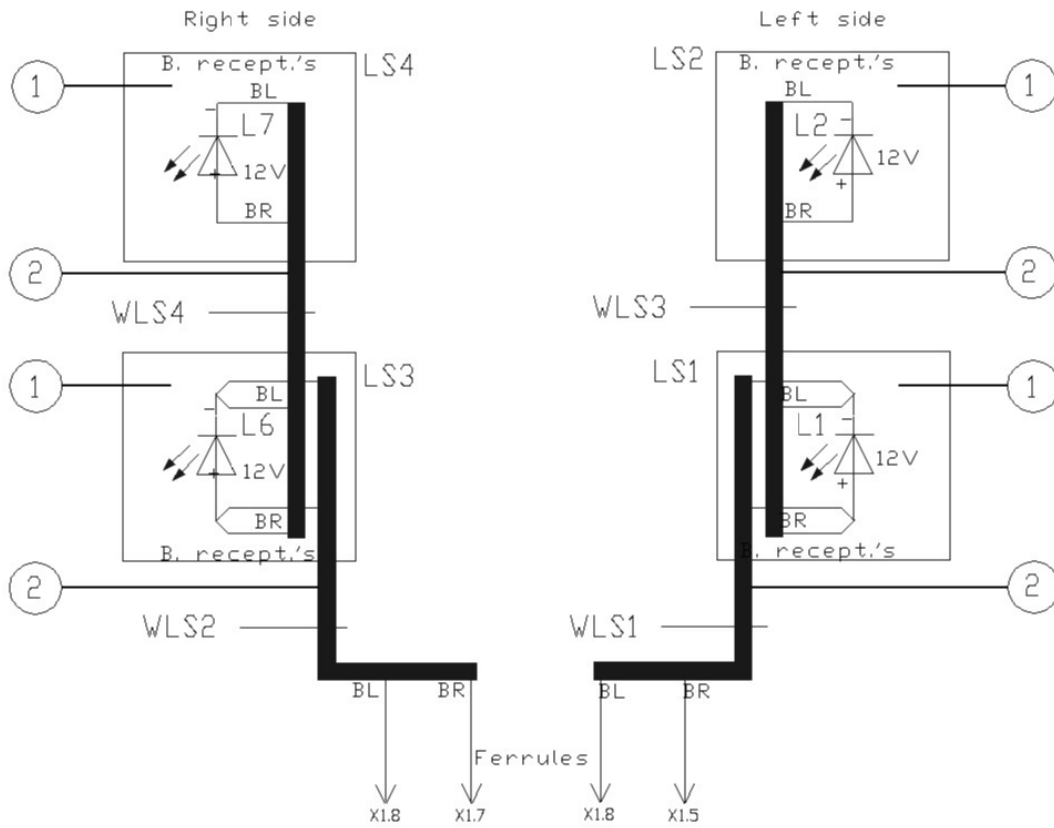

Table 9. Electrical scheme license for the plate lights

Pos	Description	Qty.
1	Rear license plate light	2
2	PVC cable	3 m

Original Instruction

### Side marking lights



Junction box  
Electrical scheme side for the marking lights

Table 10. Electrical scheme side for the marking lights

Pos	Description	Qty.
1	Side marking light	4
2	PVC cable	15 m

### Hydraulic system

The trailer is equipped with a hydraulic system for operating the functions. All of the hydraulic hoses of the trailer are marked with coloured labels (see figure below).

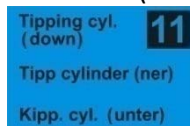

Hose label colors:

- **Red** - oil from pump.
- **Blue** - oil to tank.
- **Yellow** - Brake

Hydraulic hose functions depend on the hydraulic system configuration, see table below:

Table 11. Hydraulic hoses marking

No.	Color mark	Function
1	Yellow	Brake
10	Red	Tipping cyl. (up)
11	Blue	Tipping cyl. (down)
12	Red	Tower (front)
13	Blue	Tower (back)
14	Red	Telescope (in)
15	Blue	Telescope (out)
16	Red	Frame-lock for tipping
17	Blue	Frame-lock for hooking
18	Red	Bogie-block (on)
19	Blue	Bogie-block (off)
20	Red	Bogie-lift (on)
21	Blue	Bogie-lift (off)
22	Red	Extra port (a)
23	Blue	Extra port (b)
24	Red	Rear tailgate (a)
25	Blue	Rear tailgate (b)
26	Red	Steering control (p)
27	Blue	Steering control (t)
28	Blue	Straight steering control (t)

The trailer is delivered with the hydraulic system filled and tested. The hydraulic system consists of several functional components (see figure and table below). Technical data and configuration depends on the type of trailer.

The hydraulic system is filled with hydraulic oil **STOU 10W30**. It is applied as a working fluid of the hydraulic systems for operating in open air at temperatures ranging from -37°C up to +70°C at a continuous operating capacity. For maintenance of the hydraulic system see the chapter on Maintenance.

Original Instruction

**Tipping/rolling BIGAB 7-10 – 14-17**

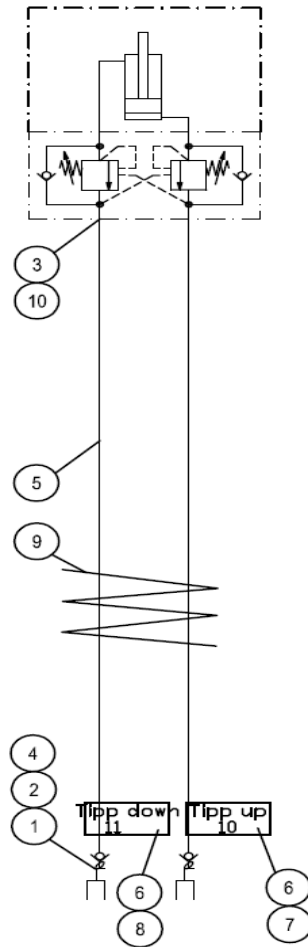

Hydraulic scheme BIGAB 7-10 – 14-17

Table 12. Hydraulic scheme tipping/rolling BIGAB 7-10 - 14-17

Pos	Description
1	Rubber seal
2	Bayonet coupling
3	Straight nipple
4	Dust cover
5	H-hose

Pos	Description
6	Heat shrink tube
7	Stricker
8	Stricker
9	Spiro pipe
10	Rubber seal

Original Instruction

**Bogie block and frame lock BIGAB 8-12 – 14-17**

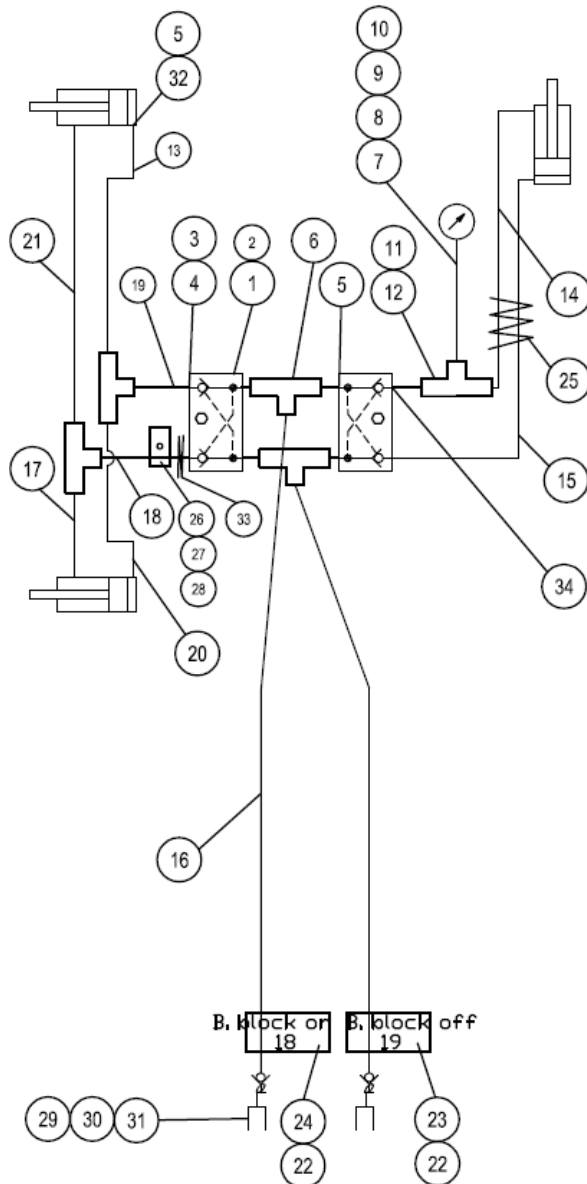

Table 13. Bogie block and frame lock

Pos	Description
1	Hyd lock
2	Bolt
3	Straight nipple
4	Straight nipple
5	Rubber seal
6	T-nipple
7	Test point
8	Hose for manometer

Pos	Description
19	H-hose
20	H-hose
21	H-hose
22	Heat shrink tube
23	Sticker
24	Sticker
25	Spiro pipe
26	Clip double

Original Instruction

9	Manometer
10	Manometer fitting
11	T-nipple
12	Adapter
13	H-hose
14	H-hose
15	H-hose
16	H-hose
17	H-hose
18	H-hose

27	Bolt
28	Cover plate
29	Bayonet coupling
30	Rubber seal
31	Dust cover
32	Angle nipple
33	Straight nipple
34	Rubber seal
35	Straight nipple (choke)

**Steerable drawbar 7-10**

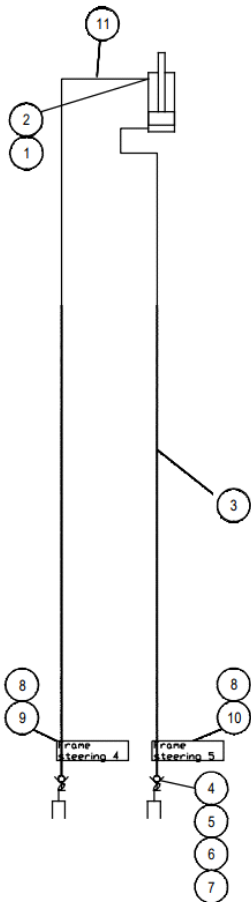

Table 14. Steerable drawbar 7-10

Pos	Description
1	Straight nipple
2	Rubber seal
3	H-hose
4	Straight nipple
5	Rubber seal
6	Bayonet coupling

Pos	Description
7	Dust cover
8	Heat shrink tube
9	Sticker
10	Sticker
11	H-hose

Hydraulic scheme. Steerable drawbar 7-10

Original Instruction

**Steerable drawbar BIGAB 8-12 – 14-17**

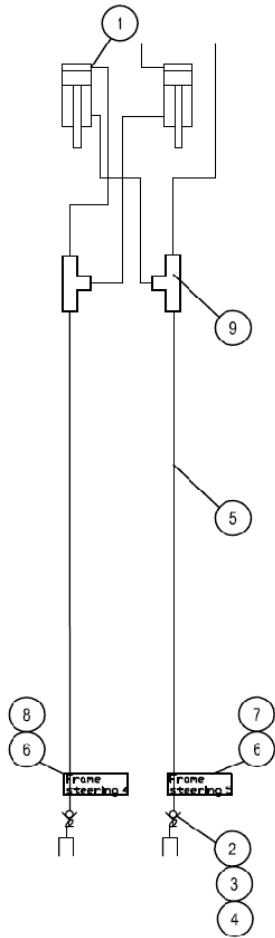

Table 15. Steerable drawbar 8-12 – 14-17

Pos	Description
1	Angle nipple
2	Rubber seal
3	Bayonet coupling
4	Dust cover
5	H-hose

Pos	Description
6	H-hose
7	H-hose
8	Heat shrink tube
9	Sticker

Hydraulic scheme. Steerable drawbar 8-12 – 14-17

*Original Instruction*

## **ADDITIONAL INFORMATION**

### **CONFORMITY OF STANDARDS**

The trailer is manufactured accordingly to the demands of the directive 2006/42/EC and therefore can be used mounted together with other equipment to provide a complete machine.

### **WARRANTY**

The guarantee will only be valid if the reseller as well the buyer signs the Warranty certificate and delivery instruction.

The warranty is valid for 12 months from the day that the product is delivered from the dealer to the end customer. AS Fors MW provides maximum 6 month warranty time during the storage of the product at the dealers. Thus, the warranty can extend up to 18 months taking into account storage at the dealer.

### **DISMANTLING AND SCRAPPING**

When deciding to withdraw the trailer from use, country specific regulations concerning withdrawal and recycling of machines must be followed.

Before dismantling, the oil from the hydraulic system must be totally removed and air pressure reduced completely from the pneumatic brake system (e.g. using air tank drain valve).

Dismantling shall be carried out by trained personnel and personal protection equipment must be used (boots, gloves, goggles, clothing, etc).

#### **Hydraulic oil**

Dismantling should be carried out on an oil resistant floor or surface. In the event of oil leaking into the environment, first the oil source must be eliminated and then the leaked oil collected with absorbents. Hydraulic oil should be taken to the appropriate facility dealing with re-use of environmentally dangerous waste. **Do not pour oil into sewerage or water tanks.**

#### **Metal parts**

All metal parts are recyclable and should, when the time comes, be handed over to a recycler.

### **PART LIST**

Only genuine spare parts may be used during repair and maintenance work. Spare parts can be found from the spare parts catalogue available on request.