

## TABLE OF CONTENTS

INTRODUCTION .....	2
1. SAFETY REGULATIONS .....	3
1.1 GENERAL SAFETY REGULATIONS.....	3
1.2 DESCRIPTION OF THE USE OF WARNING SYMBOLS .....	3
1.3 PRESENTATION OF LABELS .....	4
1.4 LOCATION OF THE LABELS ON THE TRAILER .....	6
2. SAFETY INSTRUCTIONS.....	7
2.1 BEFORE YOU START TO WORK .....	7
2.2 DRIVING .....	7
2.3 DURING MAINTENANCE .....	7
2.4 WORKING AT EXTREME CONDITIONS .....	9
2.5 ACTING IN DANGEROUS SITUATION .....	9
3. TECHNICAL DESCRIPTION OF TRAILER .....	10
3.1 TECHNICAL DATA.....	10
3.2 DESIGN OF THE TRAILER .....	11
3.3 MAIN PARTS OF TRAILER.....	12
3.3 WHEELS .....	16
3.4 HYDRAULIC SYSTEM.....	16
3.5 ELECTRICAL SYSTEM.....	18
3.6 EFC CONTROL SYSTEM .....	20
4. INSTALLATION .....	22
4.1 UNLOADING THE TRAILER.....	22
4.2 ADJUSTMENTS .....	22
4.3 WITHDRAWAL FROM USE AND STORAGE .....	22
5. FUNCTIONAL DESCRIPTION .....	23
5.1 HANDLING IN ROLL ON - ROLL OFF .....	23
5.2 HANDLING IN TIPPING .....	25
5.4 CHANGING OPERATING FUNCTION .....	26
5.5 EFC CONTROL SYSTEM HANDLING .....	27
6. MAINTENANCE.....	28
6.1 MAINTENANCE SCHEDULE.....	28
7. TROUBLESHOOTING .....	35
8. EC DECLARATION OF CONFORMITY .....	36



## INTRODUCTION

BIGAB 15 - 19 is one of the most proven and sold hook lift trailers on the market. Many are the customers who can speak about its reliability. At the same there has been interest in a BIGAB that can take different container lengths. A hook lift that can combine both short containers/bridges, 4,6 m, for contracting work as well as long ones, 6 m, for agricultural and trucking. BIGAB 15 - 19T offers our users all in one. A flexible and versatile trailer. The exchange system is built with a telescopic tower which allows handling container lengths from 4600 - 6000 mm. BIGAB 15 - 19T is as standard equipped with a hydraulic shift lock between hooking and tipping. The stable 15 - 19T is now taking a step up and becomes by so the reliable link between our smaller BIGAB models and larger.

We understand your curiosity and desire to put your BIGAB trailer to work, but we ask you to spend a little time reading through this instruction manual before you start using the machine. If not used correctly, the BIGAB hook lift trailer can cause unwanted operational halts and, in the worst case, it can be dangerous. A little time spent reading this instruction manual could save you both time and money in the future.

For your safety, it is extremely important that you follow the instructions presented in this instruction manual.

We congratulate you at your choice of trailer and wish you and your BIGAB all the best for the future!

*FORS MW conforms to ISO 7010 for safety markings in accordance with the EC directive 2006/42/EC.*

### CONTACT INFORMATION:

**Factory:**

AS FORS MW  
Tule 30  
765 05 Saue  
Estonia

Tel: + 372 679 00 00

Fax: + 372 679 00 01

E – mail: [info@forsmw.com](mailto:info@forsmw.com)

**Aftermarket:**

*Language spoken is English and Swedish.*

FMW Farma Norden AB  
Hornsväg 2  
605 97 Norrköping  
Sweden

Tel: + 46 (0) 165 770

Fax: + 46 (0) 128 370

E – mail: [aftermarket@forsmw.com](mailto:aftermarket@forsmw.com)

## 1. SAFETY REGULATIONS

### 1.1 General safety regulations



Carefully read through the user manual before using the hook lift trailer. Important data relating to your particular trailer can be found in the trailers's technical data. Incorrect usage can result in injuries to you and damage to the trailer.

Operating a trailer requires a high level of expertise, as well as knowledge about the machine you are using. It is important for you to acquire knowledge and to train with regard to the trailer's behaviour. Practice the movement pattern and always work with smaller loads until you are completely familiar with the trailer. Take care to ensure that nobody is within the safety zone 20m.

### 1.2 Description of the use of warning symbols

In the user manual we distinguish between the terms "**DANGER!**", "**WARNING!**", "**NOTE!**" and "**INFORMATION!**". These markings are used to draw the attention of readers to the fact that this is an area that is of particular importance.

**DANGER!** - a description of an imminent hazard that will result in severe injury or death if not avoided and should be limited to the most extreme situations.

**WARNING!** - a very important item of safety information is supplied with this warning symbol. A description of a potentially hazardous situation which if not avoided could result in injury or serious injury or death.

**NOTE!** - the note symbol indicates that the product, process or environment may sustain damage, as well as indicating the risk of minor injuries.

**INFORMATION!** - Important information for use of the product.

### 1.3 Presentation of labels

#### WARNING!

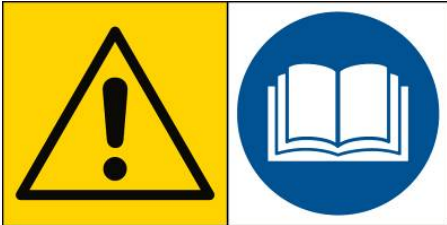

#### Warning triangle and instruction manual label

The trailer has a warning triangle next to the instruction manual label to emphasize the importance of reading the entire instruction manual carefully before using the trailer. Failure to observe this may result in serious or fatal injury.

#### INFORMATION!



#### Label for the use of safety equipment

These labels encourage the use of appropriate safety equipment in order to avoid injury when using the trailer.

#### DANGER!



#### Hydraulic fluid under pressure

Hot hydraulic fluid at high pressure levels can occur in the hydraulic system. Take care when connecting, and replace poor quality hoses.

#### WARNING!



#### Risk of slipping

There is a risk of slipping as the surfaces of the trailer can be slippery due to combination of oil/mud/rain on the surface. The ground around the trailer can also become slippery, as the tyres can tear up the surface and expose mud and soil.

#### WARNING!



#### Hazardous area

Standing between the trailer and the towing vehicle when the trailer is being driven, moved with frame steering or when other functions are activated between the trailer and towing vehicle, can be potentially fatal. As the driver, you must always ensure that no one is in the area around the machinery.

#### WARNING!



#### Maximum load on towing eyelet

Ensure that you do not load in such a way that the load on the towing eyelet exceeds the permitted laws and regulations. The trailer is designed for a maximum load of 3500 kg on the towing eyelet. The load is largely determined by the way the weight is distributed on the container bridge, and it is the user's responsibility to ensure that this is not exceeded.

**WARNING!**



**Risk of injury**

It is absolutely forbidden to board the trailer when it is moving. Anyone doing so may be at risk of serious or fatal injury.

**WARNING!**



**Hazardous movement**

It is a hazardous movement if the rear end of the tractor lifts.

**Note!** This warning label is included in the delivery of your trailer. It must be attached in a clearly visible location in the tractor cab. If you would like more of these labels, they are available to order, free of charge, from our after sales department. Contact details are visible in the first chapter.

**DANGER!**



**Risk of crushing injuries**

There is a risk of trapping and crushing injuries during operation and maintenance.

**WARNING!**

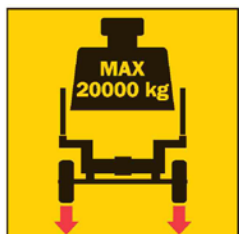

**Total weight**

It is absolutely prohibited to load more than the amount your model of trailer is designed to handle. This will be dangerous for you and your surroundings. Please check trailer specific total weight from technical data and the ID-plate.

**INFORMATION!**



**Tyre inspection**

The tyre bolts must be tightened and the brakes must be inspected and adjusted regularly.

**WARNING!**



**Use the security post during all service operations**

It is absolutely forbidden to lean under a raised frame unless it is secured with the security post. Under no circumstances may the trailer be carrying either a load or a container when using the security post.



## 2. SAFETY INSTRUCTIONS



**Read and understand the user manual carefully before using the device. Consult the user manual to solve your problems. The device has an identification label, ID-plate, on it.**

### 2.1 Before you start to work

- Carefully examine the trailer;
- Check that all bolts, nuts and hoses are connected tightly;
- Check that the trailer is safely attached to the towing vehicle;
- Check the towing eyelet for defaults;
- Control the lights;
- Check that the brakes are functioning;
- Check that hydraulic hoses and couplings are intact and free from cracks;
- Check that all hydraulic functions are working;
- Remember that it is not allowed to use this unit for functions not confirmed by producer;
- Be aware that a long container needs enough working space and turning area;
- Be sure that nobody is in the working area of the trailer;
- Respect the safety distance;
- Never stand by the drawbar when connecting and disconnecting the trailer or when functions between the towing vehicle and trailer are activated;
- Do not exceed maximum loading values;
- Verify that the hook is on the right height to suit the container;
- Study safety instruction.

### 2.2 Driving

- Don't forget to lift the parking leg up before driving;
- Do not exceed the trailers maximum travel speed;
- Never make sharp turns at high travel speed;
- Long container needs enough working space and turning area;
- Do not exceed maximum loading values;
- Be sure that the container is firmly fixed before driving;
- Recommended load placement - symmetrical.



**Never drive under obstacles such as bridges, electrical cables, etc., with the container bridge raised!**

### 2.3 During maintenance

- Make sure that the trailer is standing on a flat surface;



- Make sure that the trailer can't move;
- When lubrication or servicing the trailer, turn off the vehicle engine;
- Be sure that the trailer can't slip when using support leg, jack or similar equipment;
- Always use the security post in tipping position when servicing. The security post must always be used when carrying out service work in the tipped position. There must not be any load on the trailer when carrying out service work in the tipped position (see figures below);
- Never attempt to do maintenance work on the hydraulic system before you are sure there is no pressure;
- Do not tighten or repair leaking hydraulic couplings while the system is pressurized;
- Never attempt to localize a leakage from hoses or connections by feeling with your hand. The high-pressure oil jet blaze can penetrate skin and cause serious burns and damages. High-pressure oil is also highly flammable.
- Avoid getting oil into eyes. Use safety goggles and gloves. If oil has got into eyes flush them with cool water and immediately contact a doctor.



**It is strictly forbidden to lean underneath the container without using the security post!**

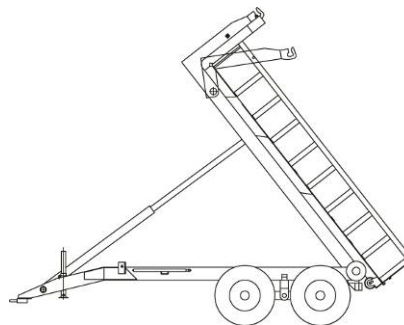

*Raised container bridge*



*Use of security post*

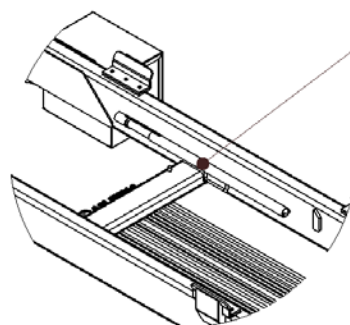

*Security post*

*Security post location*

## 2.4 Working at extreme conditions

Recommended working temperature range for a Bigab trailer is  $-30^{\circ}\text{C}$  up to  $+40^{\circ}\text{C}$ . Note that working at low temperatures accelerates hydraulic gaskets wearing and increases hydraulic hoses exposure to damages and steel constructions exposure to brittle fracture. When working at lower temperature than recommended, lift lighter loads than usual.

Before starting to work in cold conditions let the oil circulate freely through the system a few minutes. Slowly work every hydraulic function through several times so that gaskets come flexible before they receive full pressure.

At exceptionally warm conditions beware of hydraulic oils excessive heating. Too high oil temperature (above  $+80^{\circ}\text{C}$ ) degrades the oil and damages gaskets.

## 2.5 Acting in dangerous situation



**If the trailer comes into contact with high voltage electric wires comply with the following instructions:**

### **IF YOU ARE OUTSIDE THE MACHINE**

Do not attempt to get into the machine. Keep everybody out from the machines vicinity. Do not touch any part of machine.

### **IF YOU ARE INSIDE THE MACHINE**

Get out of it by JUMPING. Avoid touching any conducting parts. Do not make yourself a wire through which electricity may flow. Get away from the machine by JUMPING so that both feet do not touch the ground at the same time. Electric field at ground can cause fatal voltage between legs. At about 20 meters away you should be safe but this is of course a questions of circumstances.

### 3. TECHNICAL DESCRIPTION OF TRAILER

#### 3.1 Technical data

HOOK TRAILER	15-19T
Bogie type in standard	Mechanical pendulum
Wheel dimension in standard	500/60-22,5
Required tractor hydraulics when EFC ordered	1 brake outlet, 1 double action EFC
Oil volume (min. available oil volume with full system)	90 L
Chassi weight (with standard equipment)	4 300 kg
Chassi lenght ( $\pm 50$ mm)	7 506 mm
Width across wheels ( $\pm 30$ mm)	2 450 mm
Total weight	20 300 kg
Max load including container bridge	16 000 kg
Max load during container exchange	16 000 kg
Load on towing eye (depending on the position of the container)	2 600 - 3 500 kg
Max tipping capacity*	16 000 kg
Max working pressure	*21 MPa
Max speed	40 km/h

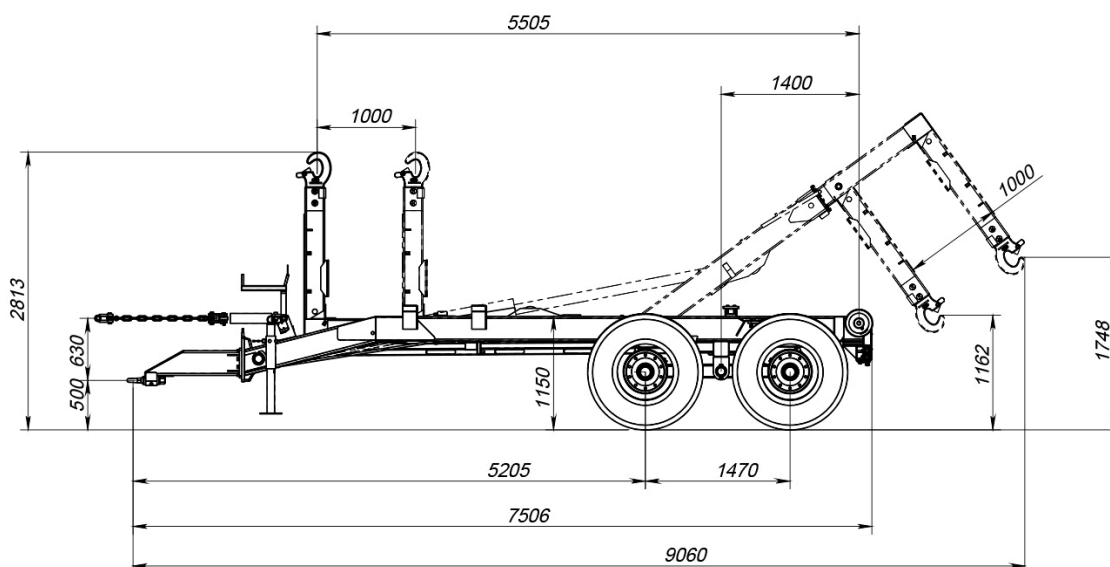

### 3.2 Design of the trailer

The trailer is constructed out of cold hollow steel sections. Through this construction the trailer receives maximum endurance and stiffness regarding both bending as well as twisting. The trailer is steady both in the tip as well as in the changing movement. The trailer is equipped with a strong pendulum bogie that has been equipped with brakes on all wheels. Optional equipment can be wheel suspension, air brakes, rear steering axle, crane, steering drawbar, hydraulic support leg, container lock and several other options. See main components, roll on-roll off positions and tipping position from figures next page.

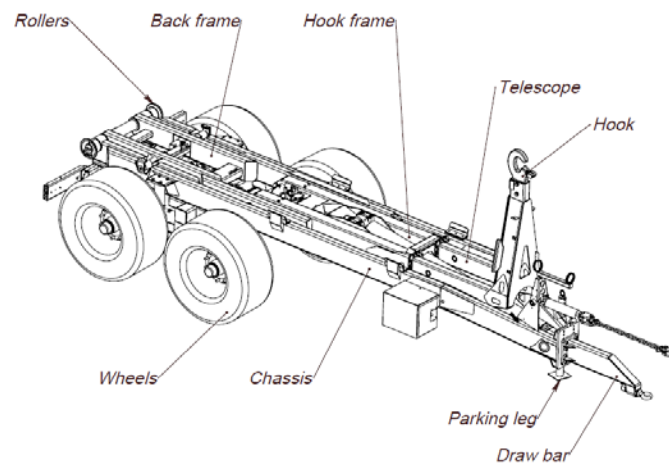

*Main components of trailer 15-19 T*

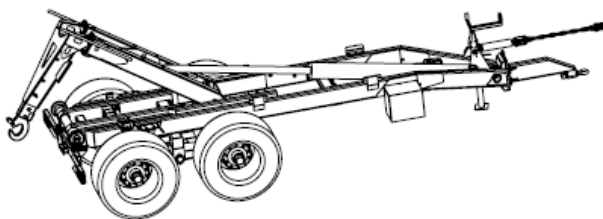

*Roll on - roll off position*

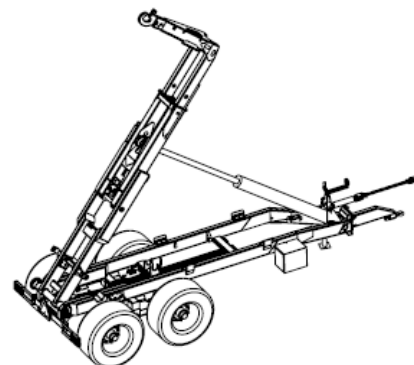

*Tipping position*

### 3.3 Main parts of trailer

The trailer consists of the following subassemblies and functional devices.

#### Chassis

Chassis is constructed of hollow steel sections (main components are shown on figure below).

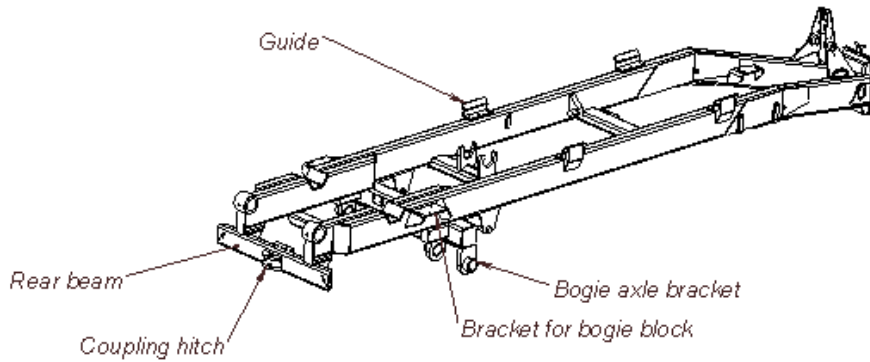

Chassis

#### Back frame

Back frame is constructed of hollow steel sections (main components are shown on figure below).

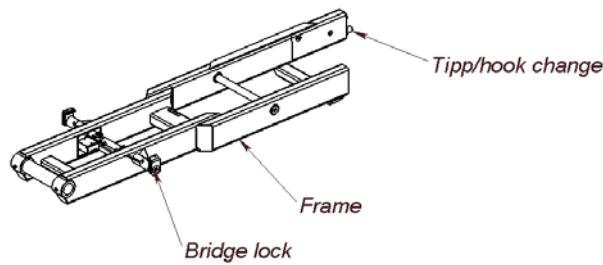

Back frame

#### Hook frame

The hooking frame with hydraulic telescope cylinders is constructed of hollow steel sections (see figure below).

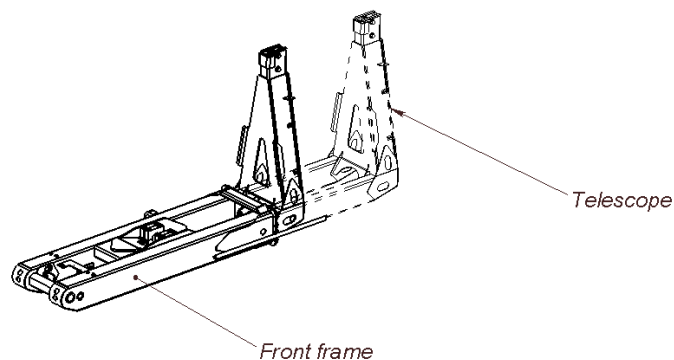

Front frame and telescope

**Bogie**

The trailer is equipped with a strong pendulum bogie that is equipped with brakes on all wheels (see figure below) and a hydraulic brake system is standard.

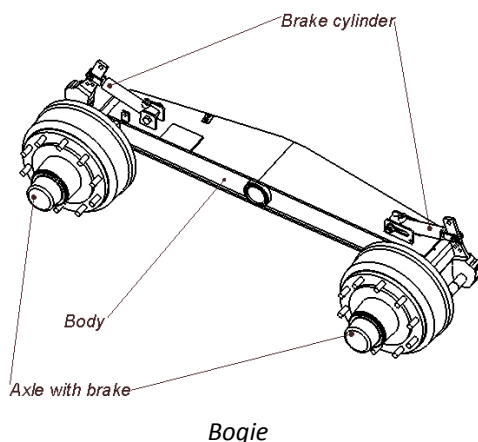

**Hook**

The Trailer is equipped with adjustable hook for three different standard container heights (see figure below).

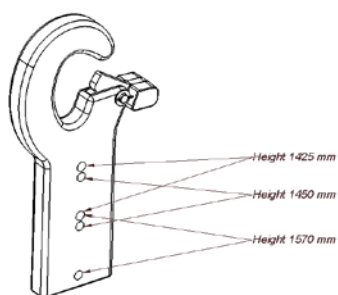

**Parking leg**

Parking leg (see figure below) is designed to be used when the trailer is under maintenance or when trailer is not in use. Before driving, the parking leg must be lifted up and fixed with the pin. An adjustable parking leg is available as additional equipment.

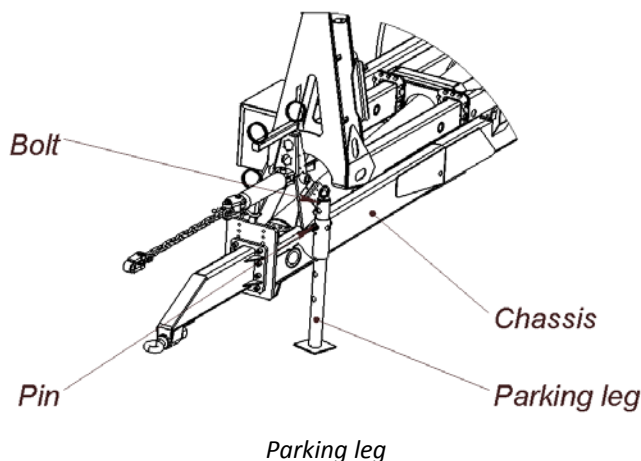

**Towing eyelet**

The towing eyelet is used to connect the trailer to the pulling vehicle (see figure below). It is **extremely important** that the towing eyelet is checked for wear and tear or exchanged every time the trailer is used.

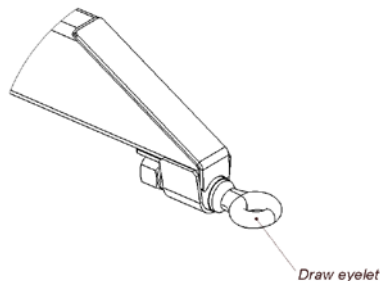

Towing eyelet

**Coupling hitch and reflector**

The coupling hitch is used for coupling other trailed devices behind the trailer. Coupling hitch is also used for coupling the reflector for slow moving vehicles (see figure below).



**If trailer is at full load then it is not allowed to attach anything to the hitch. Max load of the additionally pulled trailer is 10 t. If the front trailer is already partly loaded, you can add load in proportion to the rear trailer, but the trailers loads must not exceed the maximum weight (10 tons).**

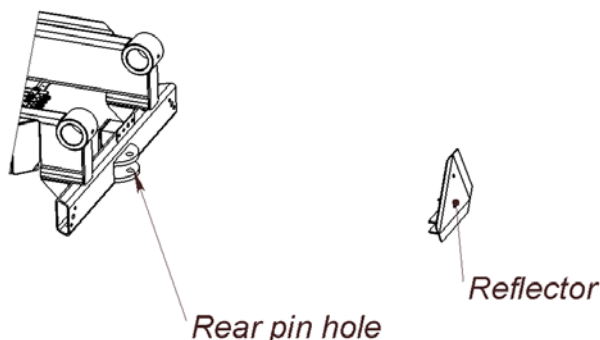

Coupling hitch and reflector

**Changing operation unit**

This unit is designed for changing operation from rolling on - rolling off to tipping (see figure below). The changing unit is located on the left side of the back frame.

If upper pin is engaged to front frame – then it is tipping.

If lower pin is engaged to chassis – then it is rolling on/off

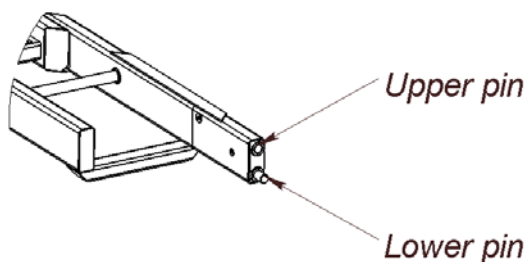

Changing unit



### 3.3 Wheels

The trailer 15-19T is equipped with 500/60-22,5 diagonal wheels (as a standard). Various alternatives (wheel types) are available, please ask from your dealer.

Wheel type	Air pressure	Speed limit, km/h
500/60-22,5	3,6*	40

\* The air pressure might be different between different wheel manufacturers. For exact air pressure we recommend taking contact with the wheel manufacturer or check information on the tyre.

### 3.4 Hydraulic system

The trailer is equipped with a hydraulic system for operating the functions. All of the hydraulic hoses of the trailer are marked with colored labels (see figure below).

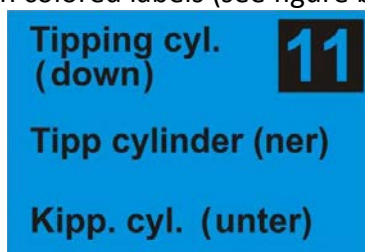

Hydraulic hose label example for tipping cylinder

Hose label colors:

- **Red** - oil from pump.
- **Blue** - oil to tank.
- **Yellow** - Brake

Hydraulic hoses functions depend of the hydraulic system configuration, see table below:

Table No. 1 - Hydraulic hoses marking

Marking	Color	Function
1	Yellow	Brake
A	White	EFC
B	White	EFC

With EFC, the hydraulic system is controlled with the switches on a control panel. 15-19T is standard equipped with the EFC control system (Electric Function Control).

The trailer is delivered with filled up and tested hydraulic system. The hydraulic system consists of several functional components (see figure and table below). Technical data and configuration depends on the type of trailer (see technical data from chapter 3.1).

The hydraulic system is filled up with hydraulic oil **VMGZ** or **SAE100R16**. It is applied as a working fluid of the hydraulic systems for operating in the open air at temperatures ranging from -50°C up to +80°C at a continuous operation service. For maintenance of the hydraulic system see chapter 6.

Tipping/rolling up-down

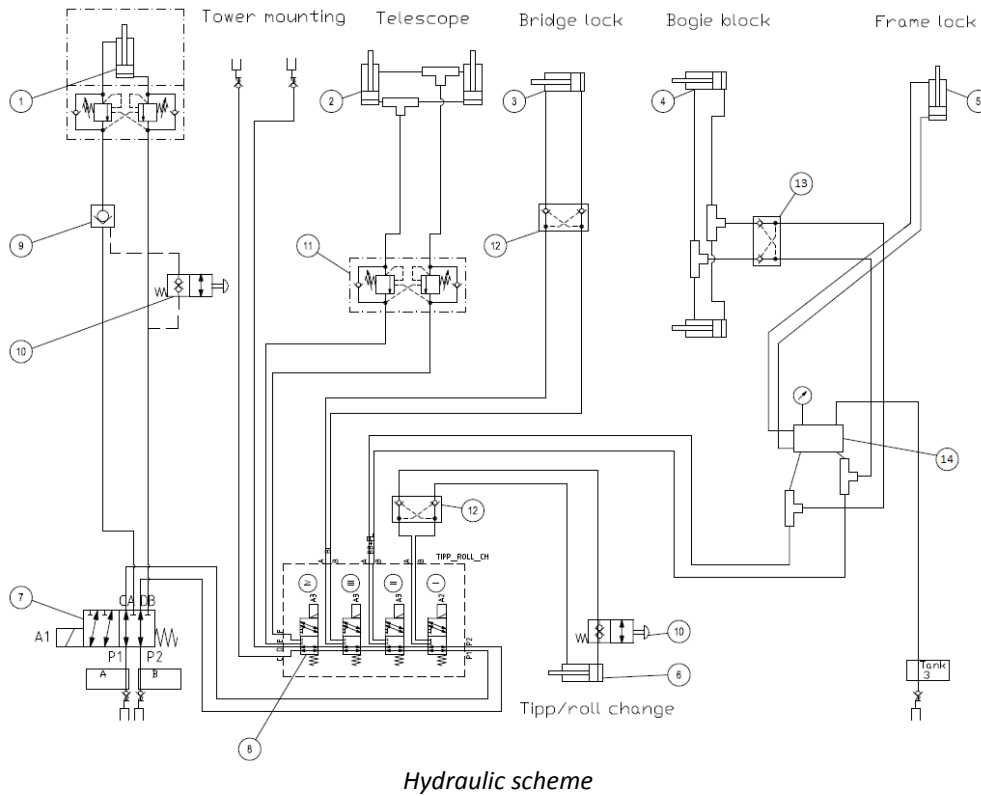

Table No. 2 - Hydraulic scheme main components

Pos	Description	Qty.
1	Tipping/Rolling cylinder	1
2	Telescope cylinder	2
3	Bridge lock cylinder	1
4	Bogie block cylinder	2
5	Frame lock cylinder	1
6	Tipp / roll change cylinder	1
7	Diverter valve	1
8	Diverter valve	4
9	Pilot operated check valve	1
10	End-of-stroke valve	2
11	Counter balance valve	1
12	Hydraulic lock	2
13	Hydraulic lock	1
14	Valve block	1

### 3.5 Electrical system

The trailer is manufactured with 12V electrical system. Configuration depends of options, example reversing light, side light or additional cable connector.

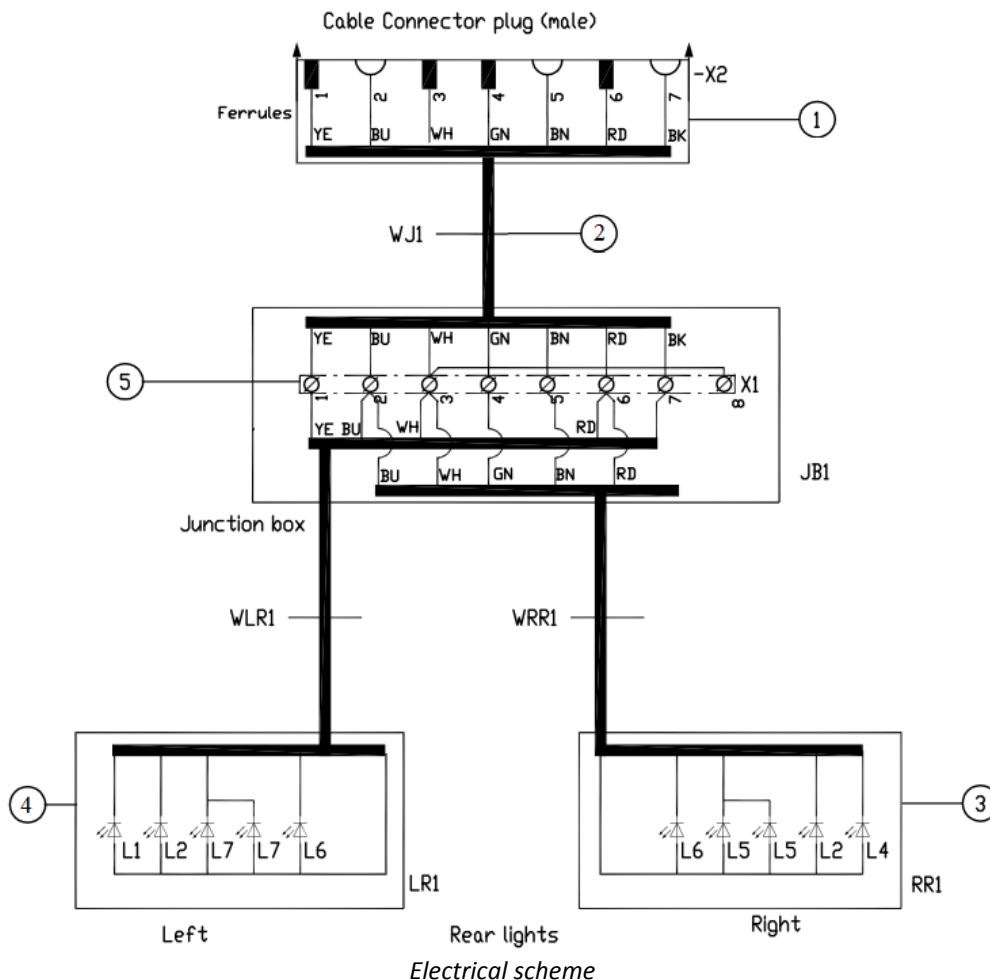

Table No. 3 - Electrical scheme main components

Pos	Description	Qty.
1	Cable conetor - 7 poles (male)	1
2	PVC cable 7x1,5mm <sup>2</sup> Cu	10,5 m
3	Right rear lights	1
4	Left rear lights	1
5	Terminal strips 10mm <sup>2</sup>	1

**NOTE!**

**Electrical cable connection for rear lights with round 7 pin cable plug  
Colours according to Fors MW, type 12N**

No	Colour	Function
1	Red (RD)	Left flash
2	Grey (GY)	Fog or reverse light
3	White (WH)	"-" Ground
4	Brown (BN)	Right flash
5	Blue	Right tail light/side marker
6	Black (BK)	Stop light
7	Yellow/ (YEGN)	Left tail light/ side marker

U1.1-2014W07-en

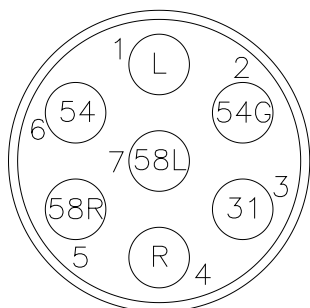

**Electrical cable connection for rear lights with round 7 pin cable plug  
Colours according to ISO 1724**

No	Pos	Colour	Function
1	L	Yellow (YE)	Left turn signal
2	54G	Blue (BU)	Fog or reverse light
3	31	White (WH)	"-" Ground
4	R	Green	Right turn signal
5	58R	Brown (BN)	Right tail light/side marker
6	54	RED (RD)	Stop light
7	58L		Left tail light/ side marker

U1.1-2014W07-en



### 3.6 EFC control system

In standard configuration the 15-19T is equipped with EFC control system (Electric Function Control).

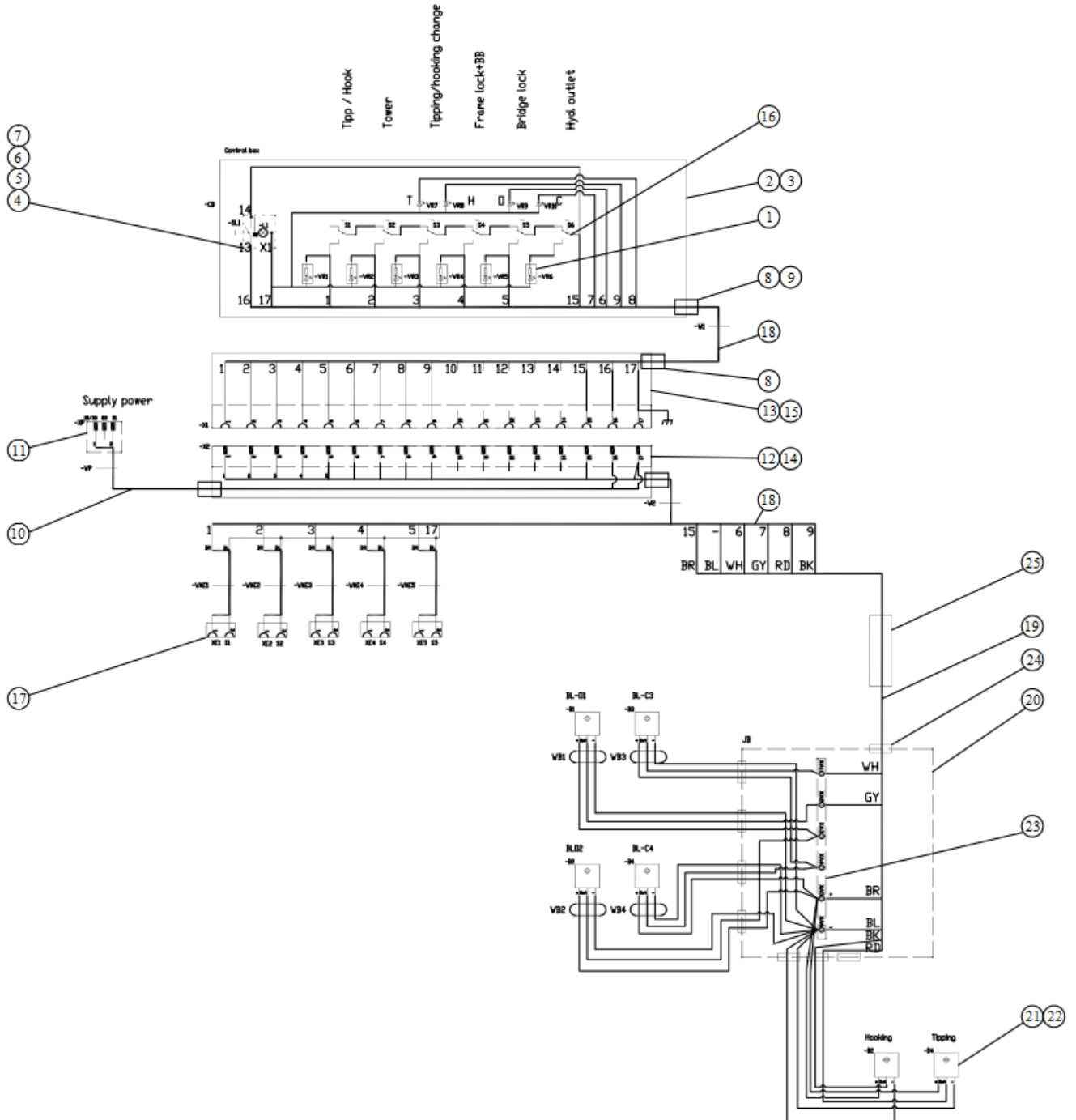

ECF electrical scheme

Table No. 4 - EFC electrical scheme main components

Pos	Description	Qty.
1	Led indicator	10
2	Connection box	1
3	End caps	2
4	Push button	1
5	Contact block	1
6	Lins GREEN	1
7	Lamp 14V MG T1 3/4	1
8	Cable gland	4
9	Nut	1
10	PVC cable	2 m
11	Cable connector 3 pools (male)	1
12	Base for connector	1
13	Housing for connector	1
14	Connector, Male insert	1
15	Connector, Female insert	1
16	Toggle switch	6
17	DIN A connector	5
18	PVC cable 18x0,75 mm <sup>2</sup>	3,1+5,5m
19	PVC cable 7x0,5 mm <sup>2</sup>	7 m
20	Connection box	1
21	Inductive proximity sensor	6
22	Cable 10m for sensor	6
23	Terminal strips 10 mm <sup>2</sup>	1
24	Grommet 5...7 mm	8
25	Steel tube	1

## 4. INSTALLATION

### 4.1 Unloading the trailer

Before starting up, check visually that the trailer is not damaged during transportation. If the trailer is damaged, inform the company that transported the trailer and the dealer or manufacturer of the product immediately.

- Usage of the trailer is strictly forbidden if safety devices of the trailer are damaged. For more detailed information about safety devices see chapter 1 and 2.
- When you are unloading and unpacking the trailer be careful: do not damage sensitive components, do not change factory settings or damage paint or other surface finishes.
- Lift up the trailer from transportation frame.
- Lower the trailer to the ground.
- Be careful when lifting so that cables, connectors or other components are not damaged for instance between lift fork and trailer frame.
- Weight depends of each type of trailer see technical information for data (chapter 3).

### 4.2 Adjustments

Quick couplings are used for connecting the towing vehicle with the trailer. These couplings serve to disconnect the hoses smoothly without their breakage and to prevent loss of oil under accidental strain and pull.

### 4.3 Withdrawal from use and storage

- It is not allowed to store the trailer in a cold and/or damp environment for a long period.
- All metal parts are recyclable and should when time comes be handed over to a recycler.

## 5. FUNCTIONAL DESCRIPTION

**Failure to read this instruction manual can be potentially fatal!**



Under no circumstances may you reverse/exert pressure with the towing vehicle in order to facilitate exchange. This entails an immediately risk of the trailer or the towing vehicle being damaged, which can be potentially fatal. The load must be pulled on to the trailer and the towing vehicle must roll in under the freely hanging load.

### 5.1 Handling in roll on - roll off

**Exchange and tipping must be operated from the operator's seat in the towing vehicle!**

If your BIGAB is equipped with suspension there is no bogie blocking.

**Ensure that the trailer is straight in front of the load!**

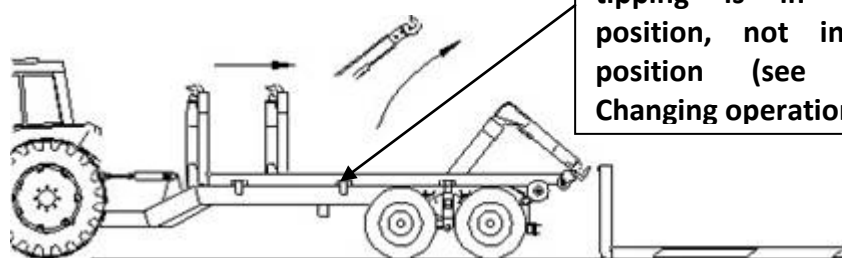

Ensure that the hydraulic position selector for exchange or tipping is in the exchange position, not in the tipping position (see chapter 3.3 Changing operation unit)!

Place the hook lift trailer on a flat surface. **The sideways incline may not exceed 5 degrees!**

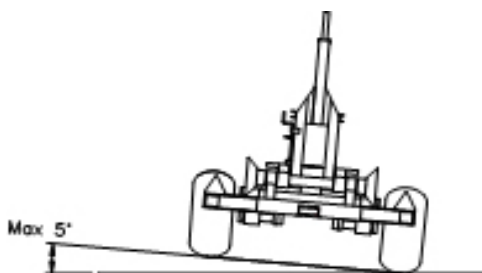

#### **On-loading!**

- Check that the load carrier is with inside the discs. Release the brakes on both the towing vehicle and the trailer to make it easier to roll on the load. Check the position of the tower during loading on, so that the container frame does not catch on to the rollers from behind.
- The tower must be completely retracted when rolling on the container bridge in order to increase lifting force and reduce the strain on the towing eyelet. Ensure that the container



frame does not catch in the rollers at the back of the trailer. Adjust the tower outwards continually during exchange in order to move clear past the rollers. If the tower is not adjusted upwards during on-loading, there is a considerable risk of the exchange's lock being damaged if the container frame catches in the rollers.



**Stop if the tractor lifts off the ground!**

Check that the hook catches around the loop!

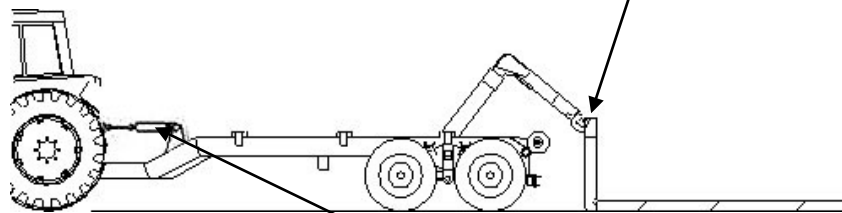

Check that the frame lock and bogie blocking are activated!



**Follow the movement with the extendable tower so that the front of the hook lift trailer's frame does not catch on to the rollers. When you have passed the rollers, always keep the hook lift trailer's frame close to the rollers.**

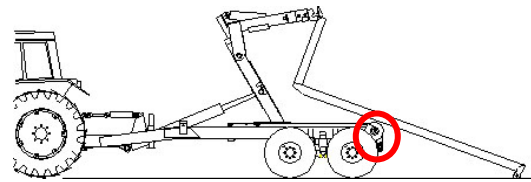
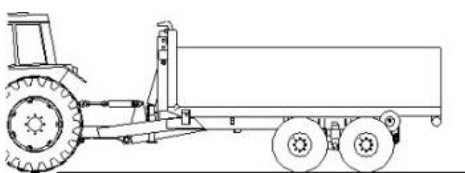

### **Off-loading!**

Release the brakes on both the towing vehicle and the trailer to make it easier to roll off the load. Check the position of the tower during off-loading so that the container frame does not catch on the rollers from above.

- Lock the frame and activate bogie blocking between the towing vehicle and trailer.
- Raise the hook lift frame slightly so that the container bridge does not scratch against the frame when you slide it backwards
- Then retract the tower backwards so that the locking rails/wings on the container bridge frame move freely and cannot be damaged.
- Adjust the tower upwards continually so that the container frame does not catch on the rollers at the back of the trailer during off-loading.
- If the tower is not adjusted during off-loading, there is a considerable risk of the exchange's lock being damaged if the container frame catches in the rollers.

## 5.2 Handling in tipping



For the model mentioned in this instruction manual, the maximum container bridge length is 6.0 m during tipping. Ensure that the towing vehicle and the trailer are securely coupled before tipping!

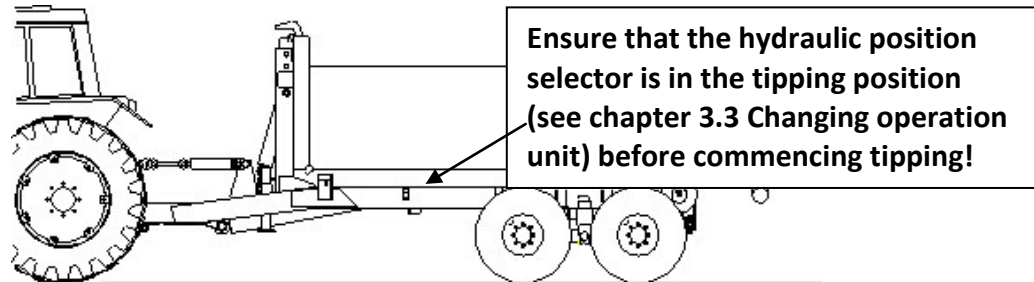

At maximum load, the telescope must be retracted 40 cm (400 mm) in order for the maximum load to be able to be tipped.

Place the hook lift trailer on a flat surface. **The sideways incline may not exceed 5 degrees!**

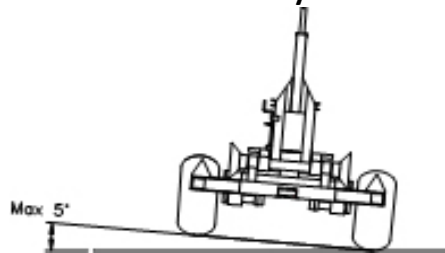

At maximum tipping angle – drive slowly forwards until the container is empty. Lower the container before continuing to drive. **Important!** Ensure that the container bridge is locked in the correct position before driving.

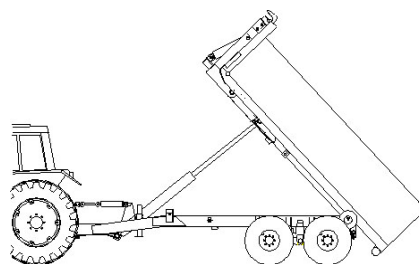

When tipping, use the brakes to ensure that the machine does not roll away when the load slides off.

### 5.3 Operation when driving



It is the responsibility of the user to ensure that a sufficiently powerful and heavy towing vehicle is coupled to the trailer in all situations. The use of a towing vehicle that is too small and insufficiently powerful can entail risks for the user and the surrounding environment, as well as leading to damage to the vehicle and trailer

Table No. 5 - Example of weight with different types of load

Load, kg	Kg/m <sup>3</sup>	Full container 7 m <sup>3</sup>	14 m <sup>3</sup>	21 m <sup>3</sup>	27 m <sup>3</sup>
Peas, Wheat, water content 15%	800	5.600 kg	11.200	16.800	21.600
Rye, water content 15%	750	5.250 kg	10.500	15.750	20.250
Barley, water content 15%	680	4.760 kg	9.520	14.280	18.360
Oats, water content 15%	560	3.920 kg	7.840	11.760	15.120
Silage, newly harvested	850	5.950 kg	11.900	17.850	22.950
Macadam	1 400	9.800 kg	19.600	29.400	37.800
Gravel	1 550	10.850 kg	21.700	32.550	41.850
Clay	1 800	12.600 kg	25.200	37.800	48.600
Wood chips (50% moisture content)	350	2.450 kg	4.900	7.350	9.450

*\*The higher the moisture content of the load, the heavier the load, a fact that the user has to take into consideration. This table is only an approximate estimate of the weights that can occur, and it is the responsibility of the user to ensure that the vehicle's limits and the applicable legislation are not being exceeded. The specified values are not exact values, just examples.*

For information purposes and for examples of how many different loads can weigh, please refer to the above table. This table should only be viewed as guidance and information. The manufacturer cannot be held responsible for dimensions or volumes specified in the table, and the table may only be viewed as a recommendation.

### 5.4 Changing operating function

Figure below shows the hydraulic changing drive between the operating functions. The changing unit is located on the left side of the back frame.

- If upper pin is engaged to front frame then it is tipping.
- If lower pin is engaged to chassis then it is hooking.

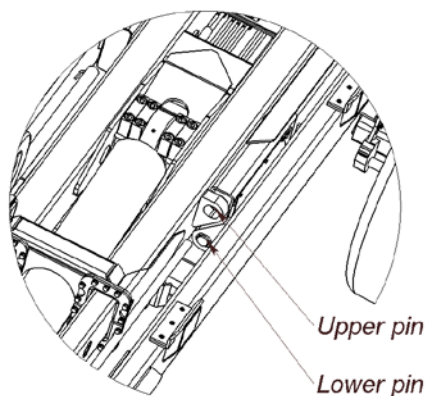

Changing operating unit



### 5.5 EFC control system handling

With EFC, the hydraulic system is controlled with the switches on a control panel. 15-19T is standard equipped with the EFC control system (Electric Function Control).

#### To operate the system:

- Connect the power supply plug to the tractors 12 VDC system;
- Switch on the power on the control panel;
- Select the function to move. The LED must lit on. By using the tractor hydraulics, move the function in required direction. NB! It is possible to switch on only one function at a time;
- Tipping/hooksing selection and bridge lock have position indicator. NB! Never stop the movement in the middle position. Wait until one of the LED is lit;
- For hooking operation open the bridge lock before moving main cylinder.



Main power switch on the side

## 6. MAINTENANCE

### 6.1 Maintenance schedule

All kinds of maintenance work are subdivided into two groups: operating (preventive) and compulsory (scheduled). The need for operating maintenance is determined based on the results of checking the equipment.

#### **General:**

- Maintenance works must be carried out regularly to ensure safe and malfunction-free operations;
- Maintenance works does not require any special tools. The user can perform most of the operations;
- Use correct tools;
- Attempt to localize the defects as precisely as possible; you should try to avoid opening the system unnecessarily;
- Keep disassembled parts and repair area protected from dirt;
- Keep spare parts in their packages until needed for installation;
- Valve adjustments and repairs are recommended to be handled by trained service personnel.

#### **Daily inspections:**

- Examine the trailer visually. Note defects and failures that might affect safety. Repair possible defects and failures. Look extra carefully at the position of the Towing eyelet;
- Check so there is no leakages on hydraulic system, or damaged hoses;
- Work through every function to its extreme position;
- Check the tyres and brakes;
- Check the oil level if trailer is equipped with pump and oil tank set;
- The towing eyelet must be controlled for excessive wear and tear every time before the trailer is used. The towing eyelet needs to be changed at least once a year under normal operation conditions. It is up to the user of the trailer to ensure that this is done.

#### **Weekly maintenance:**

- Main cylinder bolts tightening;
- Clean the trailer regularly with sponge and soap;
- When cleaning never use hot water under high pressure, it will remove the grease from bearings;
- Check the operation of the device;
- Check hydraulic pressure;
- Check the brake condition;
- Check wheel nut tightness;
- Check the bolts connecting the drawbar;
- Check the lights, reflectors and bulbs.

**Monthly maintenance:**

- Check the air pressure in tires;
- Check if there is enough lubricant on glide surfaces;
- Clean and lubricate hydraulic cylinders;
- Check hydraulic hoses for damages;

**Yearly maintenance:**

- The towing eyelet needs to be changed at least once a year under normal operation conditions. It is up to the user of the trailer to ensure that is done;

**Recommended lubricants:**

Brand	Type
BP	Energrease LS-EP2, L2M
ESSO	Beacon EP2, Multipurpose GR Moly
MOBIL	Mobilux EP2, Mobil Grease MP Special
SHELL	Alvania EP Grease 2
UNION/TEXACO	Marfak Multi-Purpose 2, Molytex Grease 2

**Tightening torques:**

Drawbar bolts:

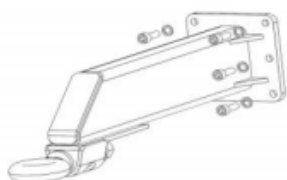

Thread	Bolt strenght	Tightening torque, Nm
M16x2	12.9	333 <sup>+15</sup>
M20x2	12.9	649 <sup>+30</sup>

Wheel nuts:

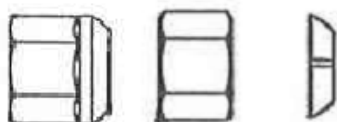

Thread	Nut strenght	Tightening torque, Nm
M18x1,5	10	270 <sup>+20</sup>
M20x1,5	10	350 <sup>+30</sup>
M22x1,5	10	450 <sup>+60</sup>

## 6.2 Maintenance operations



**Before maintenance and service operations read and understand the safety instructions!**

### ***During maintenance:***

- Be sure that the trailer is standing on a flat surface;
- Be sure that the trailer can't move;
- When lubrication or servicing the trailer, turn off the vehicle engine;
- Be sure that the trailer can't slip when you using support leg, jack or similar equipment;
- Always use the security post in tipping position when servicing;
- Never attempt to do maintenance works on the hydraulic system before you are sure there is no pressure;
- Do not tighten or repair leaking hydraulic couplings while the system is pressurized;
- Never attempt to localize a leakage from hoses or connections by feeling with your hand. The high-pressure oil jet blaze can penetrate skin and cause serious burns and damages. High-pressure oil is also highly flammable;
- Avoid getting oil into eyes. Use safety goggles and gloves. If oil has got into eyes flush them with cool water, after contact the doctor.

### ***Surface cleaning!***

Remove accumulated dust and dirt. Painted outer surfaces should be cleaned regularly with sponge and soap. When cleaning never use hot water under high pressure, it will remove the grease from bearings.

### ***Maintenance of the hydraulic units:***

- Clean and lubricate piston rods of hydraulic cylinders;
- Check the hydraulic valves: Visually check the hydraulic valves. In case of leaking replace the damaged valve;
- Check hydraulic hoses: Visually check the hydraulic hoses and pipe connections. Replace a hose in case of leaking or if there are ruptures or slashes on it;
- Check the oil level, add and replace oil if trailer is equipped with pump and oil tank set. If not then please check tractor oil level;
- Check the operation of the device;

When replacing hydraulic components such as hoses, gaskets etc, make sure they correspond with original parts. To avoid malfunctions and ensure safe operation use original spare parts.

### ***Changing the seals***

Change all the cylinder seals at the same time. The piston cannot be split. The seals must be slipped over the piston edge. Be careful not to break the seals when fitting them in place!

- After removing the old seals clean the grooves carefully before fitting the new seals into place;
- Lubricate the new seals with hydraulic oil;
- Open the pistons lock nut;
- Screw the piston off;



- Withdraw the guide piece from the rod;
- Change the guide piece seals; make sure that the piston rod seal is the right way round, i.e. the lip against the pressure.



**Never operate the hydraulic system with the level of oil dropping below lower mark!**

### ***Maintenance of the pneumatic units***

- Clean and lubricate piston rods of pneumatic cylinders;
- Emptying the water collector: Condensed water is removed from the air tank located in the side of trailer;
- Check the pneumatic valves: Check the pneumatic valves by listening to the working sound. In case of leaking replace the damaged valve;
- Check pneumatic hoses: Check visually pneumatic hoses and union pipe connections. Replace a hose if there are ruptures or slashes on it;
- Check the operation of the device.

### ***Maintenance of the electrical components***

The trailer is manufactured with 12V electrical system. Electrical system is shown in chapter 3.5. The wires to the electrical equipment are of different colors, which facilitate the location of the wire leads connecting individual items of the electrical equipment. Refer to the electrical diagram to ensure a correct subsequent reconnection of the electrical units and also when checking the operation of the equipments and individual electric circuits.

- Clean and check the lights: In case of fault replace the bulb. If the bulb keeps on braking repeatedly, find out the case of the matter, for LED lights replace the full light set;
- Check electrical connectors; Clean them of dirt and dust;
- Check wires insulation: Check wire insulation, wire joints and protection against rubbing during and contacting the trailer parts. Protect the wires from oil and fuel, which ruin insulation. Wipe dirty wires.



**Join and disjoin plug connectors only with dead circuits!**

### ***Maintenance of the brake system***

The trailer is manufactured in standard with a hydraulic brake system. Air brake system with negative or positive action is optional.

- Control the brakes regularly. Test the brakes at least once per week while trailer is working.
- See to it that no lubricant penetrates into the brakes. Any lubricant, which has penetrated the brake, causes greasing of the disks, thereby reducing friction between their working surfaces. A poor operation of the brakes is the result of such a situation. In such a case



dismantle the brake, eliminate the oil leakage, wash the greasy disks with a cleaner or gasoline and let them dry out.

- Always control the brake control linkage after the drum has being dismantled, adjust if needed. For adjusting the brakes you need to lift up the bogie-frame from the ground and adjust the brake levers. You do this by spinning the wheel while adjusting. The brakes are correctly adjusted when they spin freely without any scraping noises from the wheel.
- After all kinds of adjusting in regards to the brakes, always carry out a practical brake test before driving away.
- If the brakes seems to work poor, apply the brakes, pull the trailer maintaining low speed for a couple of hundred meters, try again through braking the vehicle while driving in a normal speed. Repeat until the brakes functions normally. If this is not helping it is necessary to contact your dealer or our service department!

BIGAB model 15-19T – the brake movement distance to the drum on the brake cylinder needs to be adjusted through loosening or vice versa tightening the adaptable screw on the brake.

### ***Maintenance of wheels***

Before starting to move the machines the wheel bolts and wheel nuts should be checked. Insure that wheel nuts are in place and that they are tightened according to 6.1 Maintenance schedule.

- Check the wheel nuts;
- Check the air pressure in the tires.

For suitable wheels air pressure see chapter 3.3 and tightening torques from chapter 6.

### ***Maintenance undercarriage***

**Every day** - It is necessary to visually check the nuts on the bogie side each time the customer uses the trailer. If the axel for the bogie side is at all moving the trailer is in **danger**. Stop at once and tighten the bolts showed in picture below (4 pcs).

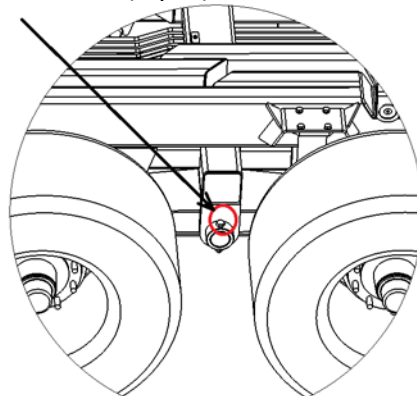

**Weekly** - Once per week (or nor later then 20 hours) it is needed to lubricate the grease nipples shown in picture below (4 pcs). You need to lean under the trailer to be able to grease the glide bearings. This will be easier to do if the trailer is without load.

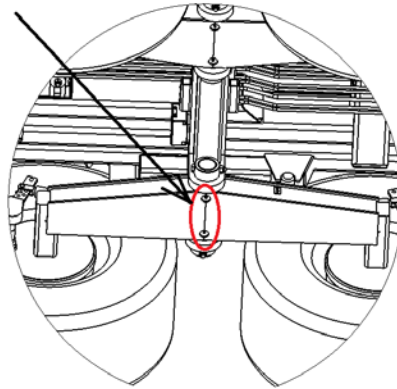

### ***Maintenance of main cylinder bolts***

The main cylinder bolts must be checked once per week for tightness. The required tightening torque is 1130 Nm.

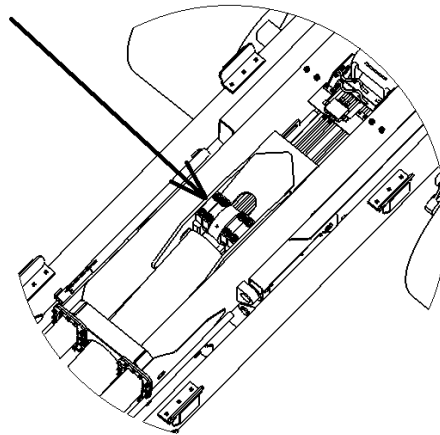

### ***Lubrication***

Recommended lubrication cycle is once per week or after 20 working hours. Lubricate points equipped with grease nipples by using a grease gun. See chapter 5.1 for recommended lubricants.

- Ensure regularity of lubrication by following the lubricating schedule.
- Keep flammable material away from heat, sparks and open fire.
- Do not let oil run into the nature. Oil spilled into ground pollutes environment.

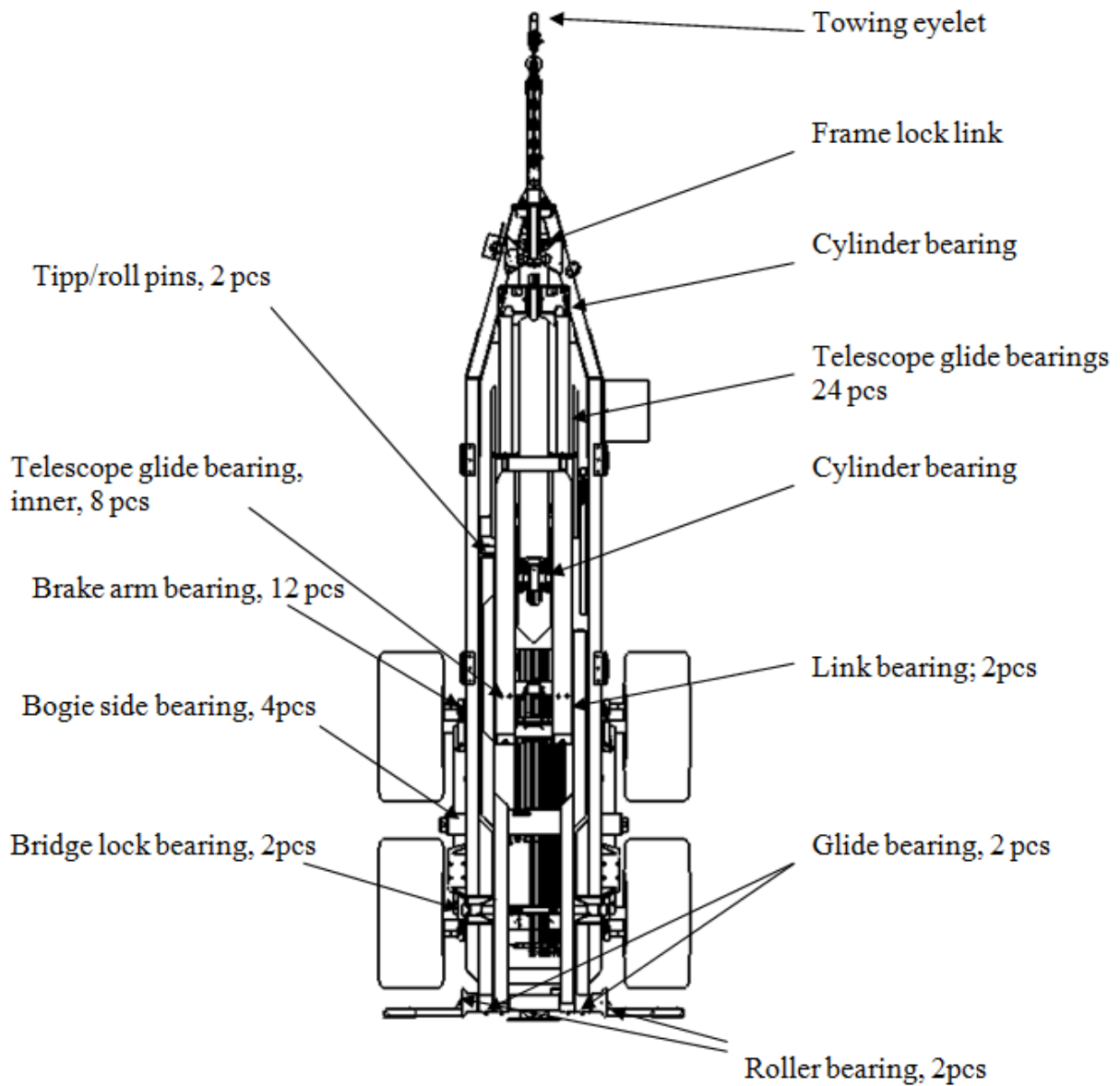

## 7. TROUBLESHOOTING

These troubleshooting instructions are provided to help you to determine the cause for a malfunction.

*Table No. 6 - Electrical equipment troubles*

Fault symptoms	Reason and action
Lights fault	Bulb burn out. Replace bulb.
	Check and clean electrical connectors.
	Check fuses.
Cable broken.	Check and repair the cable.

*Table No. 7 - Hydraulic equipment troubles*

Fault symptoms	Reason and action
Too slow lift of the function or cylinders will not return from working position to neutral.	Valve stuck. Clean valve parts. Valve should move freely without seizure.
Air in the hydraulic system.	Locate leaky point and eliminate defect.
	Check oil level.
Low oil pressure.	Adjust oil pressure.
Hydraulic cylinder piston sealing out of order or leaking.	Replace sealing.
Hydraulic system noise	Air in the system. Locate air suction and eliminate defect.
Distributor safety valve maladjusted.	Adjust valve only with trained service staff.
Oil leaking	Replace ruptured hose or tighten hose connection.
Oil leaks from electrical control valve.	Replace sealing

*Table No. 8 - Brake system troubles*

Fault symptoms	Reason and action
Poor operation of brakes	Greasy or worn-out brake pads. Wash brake drums or pads with cleaner or gasoline.
Poor brake efficiency	Adjust brake control linkage.

## 8. EC DECLARATION OF CONFORMITY

### *EC Declaration of Conformity of the Machinery*

Manufacturer:

**Fors MW AS**

Tule 30

76505 Saue

Estonia

The technical file is compiled by **Peter Kastberg**;

I hereby confirm that this **complete trailer BIGAB 15-19**:

Trade mark: **BIGAB**

Function: **complete hook lift trailer**

Model: **15-19 telescope**

Type: **BH** variant: **15-19** version: **telescope**

VIN: **V60BH1519xxxxxxxx**

Trade name: **BIGAB 15-19T**

Manufacture year: **xxxx**

is manufactured accordingly to demands in **directive 2006/42/EC** and therefore can be used mounted together with other equipment to provide a complete machine.

The equipment can't be used before the machine or the formation that it will take place in, is accordingly to the demands of the EC Machinery directive.

For the guarantee and safety, it is of uttermost significance that the instruction book is read before the machine is put into service.

Saue, Estonia

2016-07-14



Peter Kastberg

CEO