

FARMA Energy Cutter BC 18



As part of our Generation 2 series, we have released an energy cutter. **The FARMA BC 18** makes your work in the forest more productive and the permanent knives are easy to maintain. The BC 18 is suitable for our grapple loaders and doesn't require any extra controls or hoses. You couple it to the hoses intended for the grapple. Tilting takes place automatically when you are cutting (the pressure during tilting is adjustable) and it tilts up when you open the cutter again to cut a new bush or stem. For loading, we recommend our bush grapple, or the grapple loader's standard grapple. The location of the centre of gravity makes it easy to position the energy cutter directly by the root.

The cutter is intended for handling smaller trees and bushes up to a maximum diameter of 18 cm at the cutting point. Bear in mind that many things can affect whether it is possible to cut 18 cm trees; for example, the type of tree, the moisture content, the outdoor temperature and even whether the tree is frozen or not.

The FARMA BC 18 is recommended for FARMA cranes from size C 4.6 and upwards.



The strength to develop!

FARMA Generation 2; products based on the user's experience. This is innovative design and technical development that goes a step further. FARMA G2 involves an upgrade to both products and design, but it also means a further development of the brand into new lines of business. Our long experience in the industry and our

global purchasing team provide the conditions for comprehensive equipment options and competitive prices. We help you to work profitably. FARMA Generation 2 has been developed by foresters for foresters.



TECHNICAL SPECIFICATION

Technical data	BC 18
Max. cutting diameter	180 mm*
Max. grapple opening	660 mm
Max. height	437 mm
Max. pressure	190 bar
Recommended oil flow	40-60 l/min**
Tilt angle	90 degrees
Size, rotator mount	49/59***
Weight	190 kg

* The maximum cutting diameter ultimately depends on the choice of tree species.
 ** Can be used at 25 l/min, although operation becomes slow.
 *** This model is supplied with a replaceable rotator mount. Specify the desired mount when ordering.

CUTTING CAPACITY

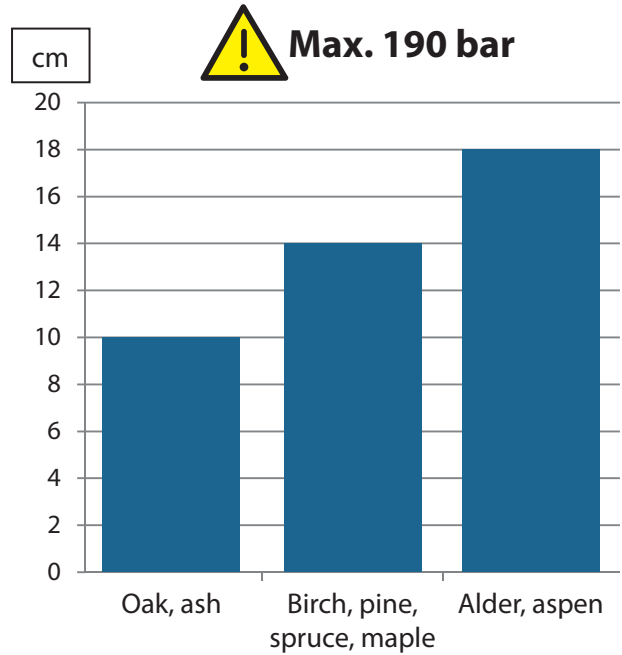

DIMENSIONAL DIAGRAM

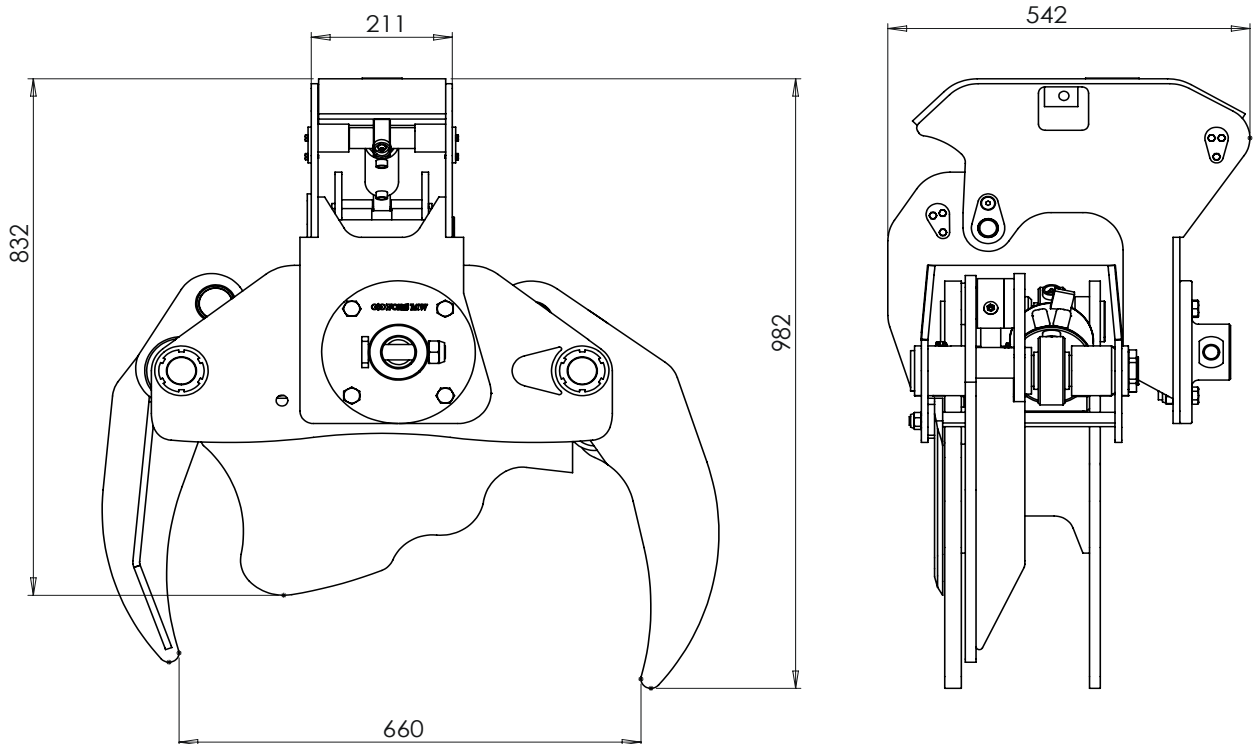

The BC 18 is also available for excavators, including for the S40 bracket. For dimensional diagrams for the excavator bracket, see www.forsmw.com.